

**O‘ZBEKISTON RESPUBLIKASI
OLYI VA O‘RTA MAXSUS TA‘LIM VAZIRLIGI**

SH. R. XURRAMOV

**MATEMATIKA
MASALALAR TO‘PLAMI
NAZORAT TOPSHIRIQLARI**

*O‘zbekiston Respublikasi Oliy va o‘rta maxsus
ta‘lim vazirligi oliy ta‘lim muassasalari uchun
o‘quv qo‘llanma sifatida tavsiya etgan*

TOSHKENT – 2018

Qoʻllanmada zarur nazariy tushunchalar, qoidalar, teoremlar va formulalar keltirilgan va ularning mohiyati misol va masalalar yechimlarida tushuntirilgan, mustahkamlash uchun mashqlar, nazorat ishi va talabalarning mustaqil ishlari uchun topshiriqlar berilgan. Har bir mustaqil ish topshirigʻiga oid misol va masala naʼmuna sifatida yechib koʻrsatilgan.

Taqrizchilar:

- A. Narmanov** – fizika-matematika fanlari doktori, OʻzMU professori;
- A. Abduraximov** – fizika-matematika fanlari nomzodi, TAQI dotsenti.

SO‘Z BOSHI

Qo‘llanma oliy ta‘lim muassasalari texnika va texnologiya bakalavr ta‘lim yo‘nalishlari Davlat ta‘lim standartlariga mos keladi va fanning o‘quv dasturlariga to‘la javob beradigan tarzda bayon qilingan.

Ushbu o‘quv qo‘llanma bakalavr ta‘lim yo‘nalishlarining 2-bosqich talabalari uchun mo‘ljallangan bo‘lib, fanning bir necha o‘zgaruvchi funksiyalarining differensial hisobi, bir necha o‘zgaruvchi funksiyalarining integral hisobi, oddiy differensial tenglamalar, qatorlar bo‘limlari bo‘yicha materiallarni o‘z ichiga oladi.

Qo‘llanmaning har bir bo‘limi zarur nazariy tushunchalar, ta‘riflar, teoremlar va formulalar bilan boshlangan, ularning mohiyati misol va masalalarning yechimlarida tushuntirilgan, shu bo‘limga oid amaliy mashg‘ulot darslarida va mustaqil uy ishlarida bajarishga mo‘ljallangan ko‘p sondagi mustahkamlash uchun mashqlar javoblari bilan berilgan.





Har bir bo‘limning oxirida nazorat ishi va talabalarning mustaqil ishlari uchun topshiriqlar variantlari keltirilgan. Har bir mustaqil ish topshirig‘ining oxirgi varianti namuna sifatida yechib ko‘rsatilgan.

Qo‘llanmani yozishda oily texnika o‘quv yurtlarining bakalavrlari uchun oily matematika fanining amaldagi dasturida tavsiya qilingan adabiyotlardan hamda o‘zbek tilida chop etilgan zamonaviy darslik va o‘quv qo‘llanmalardan keng foydalanilgan.

Qo‘llanma haqida bildirilgan fikr va mulohazalar mamnuniyat bilan qabul qilinadi.

Muallif

O‘quv qo‘llanmada *quyidagi belgilashlardan* foydalanilgan:

-  – muhim ta‘riflar;
-  – «alohida e‘tibor bering»;
- ,  – misol yoki masala yechimining boshlanishi va oxiri;

Shuningdek, muhim teorema va formulalar to‘g‘ri to‘rtburchak ichiga olingan.

I bob

BIR NECHA O'ZGARUVCHI FUNKSIYALARINING DIFFERENSIAL HISOBI

1.1. BIR NECHA O'ZGARUVCHINING FUNKSIYALARI

Funksiya tushunchasi. Funksiyaning limiti. Funksiyaning uzluksizligi

1.1.1. R^2 fazoda D va E to'plamlar berilgan bo'lsin.

☉ Agar D to'plamning har bir (x, y) haqiqiy sonlar juftiga biror qonun yoki qoida bilan E to'plamdagi yagona haqiqiy z soni mos qo'yilgan bo'lsa, D to'plamda *ikki o'zgaruvchining funksiyasi* aniqlangan deyiladi.

Ikki o'zgaruvchining funksiyasi

$$z = f(x, y), \quad z = z(x, y)$$

va boshqa ko'rinishlarda belgilanadi. Bu yerda x va y *argumentlar*, z ikki x va y o'zgaruvchining *funksiyasi* deb ataladi. D to'plamga $f(x, y)$ funksiyaning *aniqlanish sohasi*, E to'plamga uning *qiymatlar sohasi* deyiladi.

1-misol. Perimetri a ga teng uchburchakning ikki tomoni x va y ga teng. Uchburchakning yuzasini x va y orqali ifodalang.

☉ Uchburchakning uchinchi tomoni z bo'lsin. U holda $a = x + y + z$ bo'ladi. Bundan $z = a - x - y$.

Uchburchakning yuzasini Geron formulasi bilan topamiz:

$$S = \sqrt{p(p-x)(p-y)(p-z)}, \text{ bu yerda } p = \frac{a}{2}.$$

p va z ni Geron formulasiga qo'yamiz:

$$S = \sqrt{\frac{a}{2} \left(\frac{a}{2} - x \right) \left(\frac{a}{2} - y \right) \left(\frac{a}{2} - a + x + y \right)}$$

yoki

$$S(x, y) = \frac{1}{4} \sqrt{a(a-2x)(a-2y)(2x+2y-a)}. \quad \ominus$$

☞ To'g'ri burchakli dekart koordinatalar sistemasida haqiqiy sonlarning har bir (x, y) juftiga Oxy tekislikning yagona $P(x, y)$ nuqtasi mos keladi. Shu sababli ikki o'zgaruvchining funksiyasini $P(x, y)$ nuqtaning funksiyasi deb qarash va $z = f(x, y)$ yozuvni $f(P)$ kabi yozish mumkin. Bu

holda ikki o'zgaruvchi funksiyasining aniqlanish sohasi Oxy tekislik nuqtalarining biror to'plamidan yoki butun tekislikdan iborat bo'ladi.

Argumentlarning tayin $x = x_0$ va $y = y_0$ qiymatlarida (yoki $P_0(x_0; y_0)$ nuqtada) $z = f(x, y)$ funksiyaning qabul qiladigan z_0 xususiy qiymati $z_0 = z|_{\substack{x=x_0 \\ y=y_0}}$ yoki $z_0 = f(x_0, y_0)$ (yoki $z_0 = f(P_0)$) deb yoziladi.

2-misol. $f(x, y) = \frac{x(y^2 + 1)}{y}$ funksiyaning $A(2; -1)$, $B\left(\frac{x}{y}; 3\right)$, $C\left(4; \frac{y}{x}\right)$,

$D\left(\frac{x}{y}; \frac{y}{x}\right)$ nuqtalardagi xususiy qiymatlarini toping.

☞ $f(x, y)$ funksiyaning $P_0(x_0; y_0)$ nuqtadagi xususiy qiymatini topish uchun funksiyaning ifodasiga bu nuqtaning koordinatalarini qo'yish kerak.

Demak,

$$f(A) = \frac{2 \cdot ((-1)^2 + 1)}{-1} = -4; \quad f(B) = \frac{\frac{x}{y} \cdot (3^2 + 1)}{3} = \frac{10}{3} \cdot \frac{x}{y};$$

$$f(C) = \frac{4 \cdot \left(\left(\frac{y}{x}\right)^2 + 1\right)}{\frac{y}{x}} = \frac{4(y^2 + x^2)}{xy}; \quad f(D) = \frac{\frac{x}{y} \cdot \left(\left(\frac{y}{x}\right)^2 + 1\right)}{\frac{y}{x}} = \frac{y^2 + x^2}{y^2}. \quad \text{☞}$$

3-misol. $f(x^2 - y^2, x^2 + y^2) = 2xy$ bo'lsa, $f(x, y)$ ni toping.

☞ $u = x^2 - y^2$ va $v = x^2 + y^2$ belgilashlar kiritamiz va hosil bo'lgan tenglamalarni x va y ga nisbatan yechamiz:

$$\begin{cases} x^2 - y^2 = u, \\ x^2 + y^2 = v \end{cases} \text{ dan } x^2 = \frac{v+u}{2}, \quad y^2 = \frac{v-u}{2} \quad \text{yoki } x = \sqrt{\frac{v+u}{2}}, \quad y = \sqrt{\frac{v-u}{2}}.$$

Berilgan funksiyani yangi o'zgaruvchilar orqali ifodalaymiz:

$$f(u, v) = 2 \sqrt{\frac{v+u}{2}} \cdot \sqrt{\frac{v-u}{2}} = \sqrt{v^2 - u^2}.$$

u, v o'zgaruvchilarni x, y o'zgaruvchilar bilan almashtirib, topamiz:

$$f(x, y) = \sqrt{y^2 - x^2}. \quad \text{☞}$$

$z = f(x, y)$ funksiya jadval, grafik va analitik usullarda berilishi mumkin. Funksiya analitik usulda berilganda uning aniqlanish sohasi funksiyani aniqlovchi formula ma'noga ega bo'ladigan barcha nuqtalar to'plamidan iborat bo'ladi.

4-misol. Funktsiyalarning aniqlanish sohasini toping:

1) $z = \frac{3x^2 + y^2}{y - x}$; 2) $z = \arcsin(x^2 + y^2 - 8)$.

1) Funksiya $y = x$ shartda aniqlanmagan. Demak, $y \neq x$. Geometrik nuqtayi nazardan $y \neq x$ shart funksiyaning aniqlanish sohasi ikkita yarim tekislikdan tashkil topishini bildiradi. Bunda birinchi yarim tekislik $y = x$ to'g'ri chiziqdan yuqorida, ikkinchisi bu to'g'ri chiziqdan pastda yotadi (1-shakl).

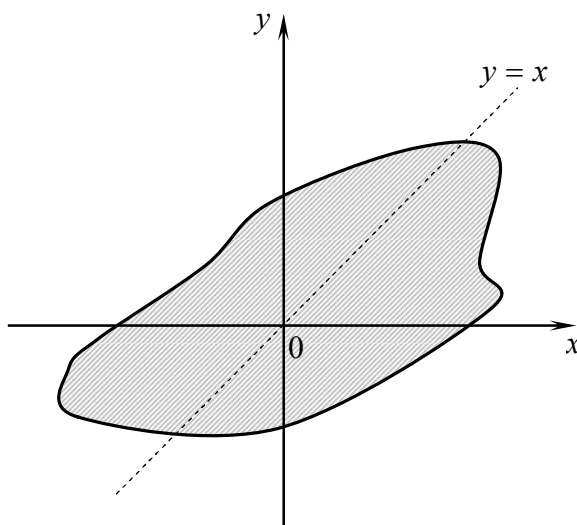

1-shakl.

2) Funksiya $-1 \leq x^2 + y^2 - 8 \leq 1$ shartda aniqlangan. Bu shart $7 \leq x^2 + y^2 \leq 9$ shartga teng kuchli. Funksiya aniqlanish sohasining chegaraviy chiziqlari bo'lgan $x^2 + y^2 = 7$ va $x^2 + y^2 = 9$ aylanalar ham bu sohaga tegishli. Demak, funksiyaning aniqlanish sohasi markazi koordinatalar boshida bo'lgan, radiuslari mos ravishda $\sqrt{7}$ va 3 ga teng aylanalar orasida va bu aylanalarda yotuvchi barcha nuqtalardan iborat bo'ladi (2-shakl).

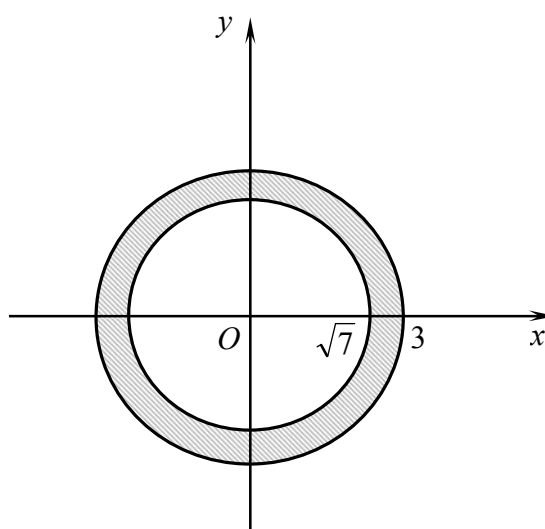

2-shakl.

R^3 fazoda D va E to'plamlar berilgan bo'lsin.

Agar D to'plamning har bir (x, y, z) haqiqiy sonlar uchligiga biror qonun yoki qoida bilan E to'plamdagi yagona haqiqiy u soni mos qo'yilgan bo'lsa, D to'plamda uch o'zgaruvchining funksiyasi aniqlangan deyiladi.

Uch o'zgaruvchining funksiyasi

$$u = f(x, y, z), u = u(x, y, z), F(x, y, z, u) = 0, \dots$$

kabi belgilanadi.

Uch o'zgaruvchining funksiyasi $P(x; y; z)$ nuqtaning funksiyasi deb qaralsa $u = f(x, y, z)$ yozuvni $f(P)$ kabi yozish mumkin. Bu holda uch o'zgaruvchi funksiyasining aniqlanish sohasi $Oxyz$ fazodagi nuqtalarining biror to'plamidan yoki butun fazodan iborat bo'ladi.

5-misol. Funksiyalarning aniqlanish sohasini toping:

$$1) u = \sqrt{3x - 2y + z - 6}; \quad 2) u = \ln(3z^2 - 2x^2 - 6y^2 - 6).$$

☞ 1) Funksiya $3x - 2y + z - 6 \geq 0$ yoki $3x - 2y + z \geq 6$ shartda haqiqiy qiymatlar qabul qiladi. Demak, funksiyaning aniqlanish sohasi $Oxyz$ koordinatalar fazosining $3x - 2y + z - 6 = 0$ tekislikda va bu tekislikdan yuqorida yotgan nuqtalar to'plamidan iborat bo'ladi.

2) Funksiya (x, y, z) uchlikning $6z^2 - 2x^2 - 3y^2 - 6 > 0$ yoki $\frac{x^2}{3} + \frac{y^2}{2} - \frac{z^2}{1} < -1$ shartni qanoatlantiruvchi qiymatlarida aniqlangan. Shu sababli bu funksiyaning aniqlanish sohasi $\frac{x^2}{3} + \frac{y^2}{2} - \frac{z^2}{1} = -1$ ikki pallali giperboloidning ichki qismidan iborat bo'ladi. ☞

To'rt o'zgaruvchining, besh o'zgaruvchining va umuman n o'zgaruvchining funksiyasi yuqoridagi kabi ta'riflanadi va belgilanadi. n o'zgaruvchining $y = f(x_1, x_2, \dots, x_n)$ funksiyasi ko'pincha R^n fazodagi $P(x_1; x_2; \dots; x_n)$ nuqtaning funksiyasi sifatida qaraladi va $y = f(P)$ deb yoziladi. n o'zgaruvchi funksiyasining aniqlanish sohasi (x_1, x_2, \dots, x_n) haqiqiy sonlar sistemasining D to'plamidan iborat bo'ladi. Bunda to'rt va undan ortiq o'zgaruvchiga bog'liq funksiyalarning aniqlanish sohasini ko'rgazmali (chizmalarda) namoyish qilib bo'lmaydi.

1.1.2. $P_0(x_0, y_0)$ nuqtaning δ -atrofi deb $\sqrt{(x - x_0)^2 + (y - y_0)^2} < \delta$ (yoki $\rho(P, P_0) < \delta$) tengsizlikni qanoatlantiruvchi barcha $P(x, y)$ tekislik nuqtalari to'plamiga aytiladi. Bu to'plam markazi P_0 nuqtada bo'lgan va radiusi δ ga teng ochiq (chegarasiz) doirada yotuvchi barcha P nuqtalardan tashkil topadi.

☑ Agar $\forall \varepsilon > 0$ son uchun $P_0(x_0, y_0)$ nuqtaning shunday δ -atrofi topilsaki, bu atrofning istalgan $P(x, y)$ nuqtasi (P_0 nuqta bundan istisno

bo‘lishi mumkin) uchun

$$|f(P) - A| < \varepsilon$$

tengsizlik bajarilsa, A songa $z = f(x, y)$ funksiyaning $P_0(x_0, y_0)$ nuqtadagi yoki $P \rightarrow P_0$ dagi limiti deyiladi va

$$\lim_{\substack{x \rightarrow x_0 \\ y \rightarrow y_0}} f(x, y) = A, \quad \lim_{(x, y) \rightarrow (x_0, y_0)} f(x, y) = A \quad \text{yoki} \quad \lim_{P \rightarrow P_0} f(P) = A$$

kabi belgilanadi.

Ta’rifga ko‘ra, $\lim_{P \rightarrow P_0} f(P) = A$ limit mavjud bo‘lsa, bu limit $P(x; y)$ nuqtaning $P_0(x_0, y_0)$ nuqtaga intilish yo‘liga bog‘liq bo‘lmaydi, ya’ni agar $\lim_{P \rightarrow P_0} f(P) = A$ bo‘lsa, u holda $P(x; y)$ nuqta $P_0(x_0, y_0)$ nuqtaga ixtiyoriy yo‘nalish va istalgan trayektoriya bo‘ylab yaqinlashganda ham bu limit A ga teng bo‘ladi.

Bir necha o‘zgaruvchi funksiya sifatidagi limiti uchun quyidagi teoremlar o‘rinli bo‘ladi.

1-teorema. $\lim_{P \rightarrow P_0} (f(P) \pm g(P)) = \lim_{P \rightarrow P_0} f(P) \pm \lim_{P \rightarrow P_0} g(P).$

2-teorema. $\lim_{P \rightarrow P_0} (f(P) \cdot g(P)) = \lim_{P \rightarrow P_0} f(P) \cdot \lim_{P \rightarrow P_0} g(P).$

1-natija. Funksiya $P \rightarrow P_0$ da yagona limitga ega bo‘ladi.

2-natija. $\lim_{P \rightarrow P_0} f(C) = C$, C – o‘zgarmas funksiya.

3-natija. $\lim_{P \rightarrow P_0} (k \cdot f(P)) = k \cdot \lim_{P \rightarrow P_0} f(P)$, $k \in R$.

4-natija. $\lim_{x \rightarrow P_0} (f(P)^k) = (\lim_{P \rightarrow P_0} f(P))^k$, $\lim_{P \rightarrow P_0} \sqrt[k]{f(P)} = \sqrt[k]{\lim_{P \rightarrow P_0} f(P)}$, $k = 1, 2, 3, \dots$

3-teorema. $\lim_{P \rightarrow P_0} \frac{f(P)}{g(P)} = \frac{\lim_{P \rightarrow P_0} f(P)}{\lim_{P \rightarrow P_0} g(P)}$, $\lim_{P \rightarrow P_0} g(P) \neq 0$.

4-teorema. Agar P_0 nuqtaning biror atrofidagi barcha P nuqtalar uchun $f(P) \leq \varphi(P) \leq g(P)$ tengsizlik bajarilsa va $\lim_{P \rightarrow P_0} f(P) = \lim_{P \rightarrow P_0} g(P) = A$ bo‘lsa, u holda $\lim_{P \rightarrow P_0} \varphi(P) = A$ bo‘ladi.

5-teorema. Agar P_0 nuqtaning biror atrofidagi barcha P nuqtalar uchun $f(P) \leq g(P)$ tengsizlik bajarilsa va $f(P)$, $g(P)$ funksiyalar $P \rightarrow P_0$ da limitga ega bo‘lsa, u holda $\lim_{P \rightarrow P_0} f(P) \leq \lim_{P \rightarrow P_0} g(P)$ bo‘ladi.

6-teorema. $\lim_{P \rightarrow P_0} g(P) = 0$, $\lim_{P \rightarrow P_0} f(P) = C \neq 0$ bo'lsin. U holda:

1) agar $\rho(P, P_0) < \delta$ ($\delta > 0$) tengsizlikni qanoatlantiruvchi barcha

P nuqtalar uchun $\frac{f(P)}{g(P)} > 0$ bo'lsa, $\lim_{P \rightarrow P_0} \frac{f(P)}{g(P)} = +\infty$ bo'ladi;

1) agar $\rho(P, P_0) < \delta$ ($\delta > 0$) tengsizlikni qanoatlantiruvchi barcha

P nuqtalar uchun $\frac{f(P)}{g(P)} < 0$ bo'lsa, $\lim_{P \rightarrow P_0} \frac{f(P)}{g(P)} = -\infty$ bo'ladi.

Agar $z = f(x, y)$ funksiyaning x va y o'zgaruvchilaridan biriga tayin qiymat berilsa, bir o'zgaruvchining $z = f(x, a)$ yoki $z = f(b, y)$ funksiyasi kelib chiqadi, bu yerda a, b - o'zgarmaslar. Bunda $x \rightarrow x_0$ da ($y \rightarrow y_0$ da) $z = f(x, a)$ ($z = f(b, y)$) funksiyaning limiti mavjud bo'lsa, bu limit a qiymatga (b qiymatga) bog'liq bo'ladi, ya'ni

$$\lim_{x \rightarrow x_0} f(x, a) = \varphi(a) \quad (\lim_{y \rightarrow y_0} f(b, y) = \psi(b)).$$

Masalan, $\lim_{(x,y) \rightarrow (x,1)} \frac{3x^2 + y}{2x - y} = \frac{3x^2 + 1}{2x - 1}$, $\lim_{(x,y) \rightarrow (x,2)} \frac{3x^2 + y}{2x - y} = \frac{3x^2 + 2}{2x - 2}$, ...

6-misol. Limitlarni toping:

1) $\lim_{(x,y) \rightarrow (1,-2)} \frac{x + 3y^2}{x^2 - 2y}$;

2) $\lim_{(x,y) \rightarrow (0,0)} \frac{x^2 + y^2}{\sqrt{x^2 + y^2 + 9} - 3}$;

3) $\lim_{(x,y) \rightarrow (0,0)} \frac{\sqrt{xy + 4} - 2}{x + y}$;

4) $\lim_{(x,y) \rightarrow (0,3)} \frac{\arcsin(xy)}{x}$;

5) $\lim_{(x,y) \rightarrow (4,0)} \frac{e^{x(x+y-4)} - 1}{2(3-y)(x+y-4)}$;

6) $\lim_{(x,y) \rightarrow (0,0)} \frac{x^2 y}{x^3 + 3y^3}$.

➤ Berilgan limitlarni limitlar haqidagi teoremlarni qo'llab, topamiz.

1) $\lim_{(x,y) \rightarrow (1,-2)} x = 1$ va $\lim_{(x,y) \rightarrow (1,-2)} y = -2$.

U holda

$$\lim_{(x,y) \rightarrow (1,-2)} \frac{x + 3y^2}{x^2 - 2y} = \frac{\lim_{(x,y) \rightarrow (1,-2)} (x + 3y^2)}{\lim_{(x,y) \rightarrow (1,-2)} (x^2 - 2y)} = \frac{\lim_{(x,y) \rightarrow (1,-2)} x + 3 \lim_{(x,y) \rightarrow (1,-2)} y^2}{\lim_{(x,y) \rightarrow (1,-2)} x^2 - 2 \lim_{(x,y) \rightarrow (1,-2)} y} = \frac{1 + 3 \cdot (-2)^2}{1^2 - 2(-2)} = \frac{13}{5}.$$

2) $x = r \cos \varphi$, $y = r \sin \varphi$ ($r > 0$) deymiz. $x^2 + y^2 = r^2$ ifoda r ning tayin qiymatida (x, y) nuqta markazi koordinatalar boshida bo'lgan r radiusli aylanada yotishini bildiradi. Bunda φ burchak 0 dan 2π gacha qiymatlarni qabul qilganda (x, y) nuqta butun aylanani qoplaydi. φ ning

0 dan 2π gacha o'zgarishida r ga ixtiyoriy musbat son berib aylananing istalgan nuqtasiga tushish mumkin. Shu sababli $r \rightarrow 0$ shart $(x, y) \rightarrow (0, 0)$ shartga teng kuchli bo'ladi.

Demak,

$$\lim_{(x,y) \rightarrow (0,0)} \frac{x^2 + y^2}{\sqrt{x^2 + y^2 + 9} - 3} = \lim_{r \rightarrow 0} \frac{r^2}{\sqrt{r^2 + 9} - 3} = \lim_{r \rightarrow 0} \frac{r^2(\sqrt{r^2 + 9} + 3)}{r^2} = \lim_{r \rightarrow 0} (\sqrt{r^2 + 9} + 3) = 6.$$

3) $(0;0)$ nuqtaga $y = kx$ to'g'ri chiziq bo'ylab yaqinlashamiz.

U holda

$$\begin{aligned} \lim_{(x,y) \rightarrow (0,0)} \frac{\sqrt{xy + 4} - 2}{x + y} &= \lim_{x \rightarrow 0} \frac{\sqrt{kx^2 + 4} - 2}{(1+k)x} = \lim_{x \rightarrow 0} \frac{kx^2}{(1+k)x(\sqrt{kx^2 + 4} + 2)} = \\ &= \lim_{x \rightarrow 0} \frac{kx}{(1+k)(\sqrt{kx^2 + 4} + 2)} = \frac{0}{4(1+k)} = 0. \end{aligned}$$

4) $x \rightarrow 0, y \rightarrow 3$ da $xy \rightarrow 0$. Bundan $\lim_{\alpha \rightarrow 0} \frac{\arcsin \alpha}{\alpha} = 1$ tenglikni qo'llab,

topamiz:

$$\lim_{(x,y) \rightarrow (0,3)} \frac{\arcsin(xy)}{x} = \lim_{(x,y) \rightarrow (0,3)} \frac{\arcsin(xy)}{xy} \cdot \frac{xy}{x} = \lim_{(x,y) \rightarrow (0,3)} y = 3.$$

5) $x \rightarrow 4, y \rightarrow 0$ da $x + y - 4 \rightarrow 0$. $\lim_{\alpha \rightarrow 0} \frac{e^\alpha - 1}{\alpha} = 1$ tenglikni qo'llab, topamiz:

$$\lim_{(x,y) \rightarrow (4,0)} \frac{e^{x(x+y-4)} - 1}{2(3-y)(x+y-4)} = \lim_{(x,y) \rightarrow (4,0)} \frac{e^{x(x+y-4)} - 1}{x(x+y-4)} \cdot \frac{x}{2(3-y)} = \lim_{(x,y) \rightarrow (4,0)} \frac{x}{2(3-y)} = \frac{2}{3}.$$

6) $(0;0)$ nuqtaga $y = kx$ to'g'ri chiziq bo'ylab yaqinlashamiz:

$$\lim_{(x,y) \rightarrow (0,0)} \frac{x^2 y}{x^3 + 3y^3} = \lim_{x \rightarrow 0} \frac{x^2 kx}{x^3 + 3k^3 x^3} = \frac{k}{1 + 3k^3}.$$

Bu limitning qiymati to'g'ri chiziqning burchak koeffitsiyentiga bog'liq: $k = 1$ da (ya'ni nuqta $y = x$ to'g'ri chiziq bo'ylab harakatlenganda)

limit $\frac{1}{4}$ ga teng; $k = 2$ da (ya'ni nuqta $y = 2x$ to'g'ri chiziq bo'ylab

harakatlenganda) limit $\frac{2}{25}$ ga teng va hokazo. Shunday qilib, $P(x; y)$ nuqta

koordinatalar boshiga turli yo'nalishlar bo'ylab yaqinlashganda funksiya turli limitlarga ega bo'ladi.

Demak, $\lim_{(x,y) \rightarrow (0,0)} \frac{x^2 y}{x^3 + 3y^3}$ limit mavjud bo'lmaydi. 

1.1.3. $z = f(P)$ funksiya $P_0(x_0; y_0)$ nuqtaning biror atrofda aniqlangan bo'lsin.

☑ Agar $f(P)$ funksiya P_0 nuqtada chekli limitga ega bo'lib, bu limit funksiyaning shu nuqtadagi qiymatiga teng, y'ani $\lim_{P \rightarrow P_0} f(P) = f(P_0)$ bo'lsa, u holda $f(P)$ funksiya $P_0(x_0; y_0)$ nuqtada uzluksiz deyiladi.

Nuqtada uzluksiz funksiyalar uchun quyidagi teoremlar o'rinli bo'ladi.

1-teorema. $f(P)$ va $g(P)$ funksiyalar P_0 nuqtada uzluksiz bo'lsa, u holda $f(P) \pm g(P)$, $f(P) \cdot g(P)$ va $\frac{f(P)}{g(P)}$ ($g(P_0) \neq 0$) funksiyalar ham P_0 nuqtada uzluksiz bo'ladi.

2-teorema. $f(P)$ funksiya $P_0(x_0, y_0)$ nuqtaning biror atrofda aniqlangan va P_0 nuqtada uzluksiz bo'sin, bunda $f(P)$ qiymat Q_0 nuqtaning biror atrofida tushsin va $f(P_0) = Q_0$ bo'lsin. Agar $g(Q)$ funksiya $Q_0(u_0; v_0)$ nuqtaning biror atrofda aniqlangan va bu nuqtada uzluksiz bo'lsa, u holda $g(f(P))$ murakkab funksiya $P_0(x_0; y_0)$ nuqtada uzluksiz bo'ladi.

3-teorema. Agar $f(P)$ funksiya P_0 nuqtada uzluksiz va $f(P_0) > 0$ ($f(P_0) < 0$) bo'lsa, u holda P_0 nuqtaning biror atrofida $f(P) > 0$ ($f(P) < 0$) bo'ladi.

4-teorema. Agar $f(P)$ funksiya P_0 nuqtada uzluksiz bo'lsa, u holda $\lim_{P \rightarrow P_0} f(P) = f(\lim_{P \rightarrow P_0} P)$ bo'ladi.

5-teorema. Agar $f(P)$ funksiya $P_0(x_0; y_0)$ nuqtada uzluksiz bo'lsa, u holda $f(P)$ funksiya P_0 nuqtaning biror atrofida chegaralangan bo'ladi.

☑ Agar $f(P)$ funksiya P_0 nuqtada aniqlanmagan yoki $\lim_{P \rightarrow P_0} f(P) \neq f(P_0)$ bo'lsa P_0 nuqtaga $f(P)$ funksiyaning uzulish nuqtasi deyiladi.

7-misol. Funksiyalarning uzilish nuqtalarini toping:

$$1) z = \frac{2x^2 - y^2 + 4}{x^2 + y^2}; \quad 2) z = \ln(x^2 + 2y^2).$$

☞ 1) $z = \frac{2x^2 - y^2 + 4}{x^2 + y^2}$ funksiya $P_0(0,0)$ nuqtada aniqlanmagan.

Demak, $O(0,0)$ nuqta funksiyaning uzilish nuqtasi.

2) $z = \ln(x^2 + 2y^2)$ funksiya $O(0,0)$ nuqtada aniqlanmagan va bu nuqta funksiyaning uzulish nuqtasi bo'ladi. ☹

⇒ 1. Tekislikdagi D to‘plamning ixtiyoriy ikki nuqtasini shu to‘plam nuqtalaridan tashkil topgan uzluksiz chiziq bilan tutashtirish mumkin bo‘lsa, D to‘plamga *bog‘lamli to‘plam* deyiladi.

2. Tekislikdagi D to‘plamning M nuqtasi uchun shu to‘plam nuqtalaridan tashkil topgan δ – atrof mavjud bo‘lsa, M nuqtaga D to‘plamning *ichki nuqtasi* deyiladi.

3. Agar P nuqtaning ixtiyoriy δ – atrofida berilgan to‘plamga tegishli bo‘lgan va tegishli bo‘lmagan nuqtalar mavjud bo‘lsa, P nuqta berilgan to‘plamning *chegaraviy nuqtasi* deb ataladi. To‘plamning barcha chegaraviy nuqtalari to‘plamiga uning *chegarasi* deyiladi.

4. Faqat ichki nuqtalardan tashkil topgan D to‘plamga *ochiq to‘plam* deyiladi.

5. Bog‘lamli ochiq D to‘plamga *ochiq soha* yoki *soha* deyiladi

6. Soha va uning chegarasidan tashkil topgan to‘plamga *yopiq soha* deyiladi.

7. Agar berilgan sohani to‘la qoplaydigan, ya’ni sohaning barcha nuqtalarini o‘z ichiga oladigan doirani tanlash mumkin bo‘lsa, u holda bu sohaga *chegaralangan soha*, aks holda *chegaralanmagan soha* deyiladi.

$f(P)$ funksiya ochiq yoki yopiq sohaning har bir nuqtasida uzluksiz bo‘lsa, u shu *sohada uzluksiz* deb ataladi.

Sohada uzluksiz funksiyalar uchun qoyidagi teoremlar o‘rinli bo‘ladi.

6-teorema (Bolsano-Koshi teoremasi). Agar $f(P)$ funksiya bog‘lamli D to‘plamda uzluksiz bo‘lib, uning ikkita turli nuqtalarida har xil ishorali qiymatlar qabul qilsa, u holda D to‘plamda shunday P nuqta topiladiki, $f(P) = 0$ bo‘ladi.

7-teorema (Beershtass teoremasi). Agar $f(P)$ funksiya yopiq D sohada uzluksiz bo‘lsa, u holda $f(P)$ funksiya bu sohada chegaralangan bo‘ladi. Bunda uzluksiz funksiya yopiq sohada o‘zining eng kichik va eng katta qiymatlariga erishadi.

8-misol. Funksiyalarni uzluksizlikka tekshiring:

$$1) z = \frac{1}{5x - 2y + 4}$$

$$2) z = \frac{1}{x^2 + y^2 - z^2}.$$

⊕ 1) Funksiya $5x - 2y + 4 = 0$ tenglamani qanoatlantiradigan nuqtalardan tashqari barcha nuqtalarda aniqlangan va uzluksiz. Bu tenglama funksiya aniqlanish sohasining chegarasidan iborat bo‘lgan to‘g‘ri chiziqni ifodalaydi. Bu to‘g‘ri chiziqning har bir nuqtasi funksiyaning uzilish nuqtasi

bo‘ladi. Shunday qilib, berilgan funksiya uzilish nuqtalari butun bir to‘g‘ri chiziqni tashkil qiladi.

2) Funksiya maxraji nolga teng bo‘lgan, ya’ni $x^2 + y^2 - z^2 = 0$ tenglikni qanoatlantiruvchi nuqtalarda aniqlanmagan. Demak, $x^2 + y^2 = z^2$ konus sirti berilgan funksiyaning uzilish nuqtalari bo‘ladi. ☹

Mustahkamlash uchun mashqlar

1.1.1. Perimetri x ga teng bo‘lgan teng yonli trapetsiyaga radiusi y ga teng bo‘lgan aylana ichki chizilgan. Trapetsiyaning yuzasini x va y orqali ifodalang.

1.1.2. R radiusli sharga asosi to‘g‘ri to‘rtburchakdan iborat bo‘lgan piramida ichki chizilgan. Piramidaning balandligi to‘g‘ri to‘rtburchakning diagonallari kesishish nuqtasidan o‘tadi va sharning markazi bu balandlikda yotadi. Piramidaning hajmini to‘g‘ri to‘rtburchakning x va y o‘lchamlari orqali ifodalang.

1.1.3. Perimetri a ga teng bo‘lgan to‘rtburchakning yuzasini uning uchta x, y va z tomonlari orqali ifodalang.

1.1.4. Konusga ichki chizilgan sharning radiusini konusning uchta x, y va z o‘lchami orqali ifodalang, bu yerda x – radius, y – balandlik, z – yasovchi.

1.1.5. $f(x, y) = \frac{x^3 - y^3}{x^2 y}$ funksiyaning $A(2;1)$, $B\left(\frac{1}{x}; \frac{1}{y}\right)$, $C\left(\frac{x}{y}; \frac{y}{x}\right)$ nuqtalardagi xususiy qiymatlarini toping.

1.1.6. $f(x, y) = \frac{(x - y)^2}{xy}$ funksiyaning $A(-1;2)$, $B\left(\frac{1}{y}; \frac{1}{x}\right)$, $C\left(\frac{x}{y}; \frac{y}{x}\right)$ nuqtalardagi xususiy qiymatlarini toping.

1.1.7. $f\left(\frac{x+y}{a}, \frac{x-y}{b}\right) = \frac{y}{x}$ bo‘lsa, $f(x, y)$ ni toping.

1.1.8. $f\left(\frac{x}{y}, \frac{y}{x}\right) = \frac{3x^2 - 4y^2}{xy}$ bo‘lsa, $f(x, y)$ ni toping.

1.1.9. Funktsiyalarning aniqlanish sohasini toping:

- 1) $z = \arcsin \frac{y-1}{x}$;
- 2) $z = \sqrt{1 - \frac{x^2}{9} + \frac{y^2}{16}}$;
- 3) $z = \frac{x-6}{x^2 + y^2 - 9}$;
- 4) $z = \frac{1}{\sqrt{x^2 + 2x + y^2 - 4y - 4}}$;
- 5) $z = \ln(x^2 - y^2 - 25)$;
- 6) $z = \sqrt{\sin(x^2 + y^2)}$;
- 7) $z = \frac{\sqrt{4x - y^2}}{\ln(1 - x^2 - y^2)}$;
- 8) $z = \frac{1}{\sqrt{x - \sqrt{y}}}$;
- 9) $z = \sqrt{1 + \sqrt{-(2x + y)^2}}$;
- 10) $z = \ln(x^2 + y^2 - 9) + \sqrt{16 - x^2 - y^2}$;
- 11) $u = \sqrt{x} + \sqrt{y} + \sqrt{z}$;
- 11) $u = \sqrt{z - \frac{x^2}{16} - \frac{y^2}{25}}$;
- 13) $u = \arcsin \frac{\sqrt{x^2 + y^2}}{z}$;
- 14) $u = \frac{1}{\ln(1 - x^2 - y^2 - z^2)}$;
- 15) $u = \sqrt{1 - \frac{x^2}{a^2} - \frac{y^2}{b^2} + \frac{z^2}{c^2}}$;
- 16) $u = \arcsin \frac{x + y + z - a}{a}$.

1.1.10. Limitlarni toping:

- 1) $\lim_{(x,y) \rightarrow (0,0)} \frac{9xy}{2 - \sqrt{4 - 3xy}}$;
- 2) $\lim_{(x,y) \rightarrow (0,0)} \frac{1 - \sqrt{1 - x^2 y}}{xy^2}$;
- 3) $\lim_{(x,y) \rightarrow (0,0)} \frac{x^2 - y^2}{x^2 + y^2}$;
- 4) $\lim_{(x,y) \rightarrow (0,0)} (x + 2y) \sin\left(\frac{1}{x + y}\right) \cos\left(\frac{y}{2x + y}\right)$;
- 5) $\lim_{(x,y) \rightarrow (0,0)} \frac{xy^2}{x^2 + y^2}$;
- 6) $\lim_{(x,y) \rightarrow (0,0)} \frac{\arctg(xy^2)}{x^2 y}$;
- 7) $\lim_{(x,y) \rightarrow (1,1)} \frac{\sin(3x + y - 4)}{(3x + y)^2 - 16}$;
- 8) $\lim_{(x,y) \rightarrow (2,-2)} \frac{\ln(x^2 + y - 1)}{x^2 + y - 2}$;
- 9) $\lim_{(x,y) \rightarrow (\infty, 0)} \left(1 + \frac{1}{x}\right)^{\frac{x^2}{x+y}}$;
- 10) $\lim_{(x,y) \rightarrow (0,0)} (1 + x^2 + y^2)^{-\frac{1}{x^2 + y^2}}$;
- 11) $\lim_{(x,y) \rightarrow (1,-1)} \frac{\sin(x + y) \cdot e^{x-y}}{x^3 + y^3}$;
- 12) $\lim_{(x,y) \rightarrow (2,0)} \frac{e^{\sin xy} - 1}{2y(x + y)}$;
- 13) $\lim_{(x,y) \rightarrow (0,0)} \frac{3\sin^2 x - \sin y^2}{\sqrt{9 + \sin y^2} - 3\sin^2 x - 3}$;
- 14) $\lim_{(x,y) \rightarrow (2,-2)} \frac{x^2 - y^2}{(x - 2)^2 - (2 + y)^2}$.

1.1.11. Funktsiyalarning uzilish nuqtalarini toping:

$$1) z = \frac{x^2 y^2}{x^2 + y^2};$$

$$2) z = \frac{xy}{x^2 + y^2};$$

$$3) z = e^{-\frac{y}{x^2+y^2}};$$

$$4) z = \frac{1}{\sqrt{x+y-3} + \sqrt{x-y-5}}.$$

1.1.12. Funktsiyalarni uzluksizlikka tekshiring:

$$1) z = \frac{1}{x^2 - y^2};$$

$$2) z = \frac{2x + y^2}{2x - y^2};$$

$$3) u = \frac{5}{x + 2y + z - 6};$$

$$4) u = \frac{1}{x^2 + y^2 + z^2 - 1}.$$

1.2. BIR NECHA O'ZGARUVCHINING FUNKSIYASINI DIFFERENSIALLASH

**Funksiyaning xususiy hosilalari. Funksiyaning differensial.
Sirtga o'tkazilgan urinma tekislik va normal. Murakkab funktsiyani
differensiallashtirish. Oshkormas funktsiyani differensiallashtirish.
Yuqori tartibli hosila va differensiallar**

1.2.1. $z = f(x, y)$ funktsiya $D \subset R^2$ to'plamda aniqlangan va uzluksiz bo'lib, $P_0(x_0; y_0)$, $P_1(x_0 + \Delta x; y_0)$, $P_2(x_0; y_0 + \Delta y)$ va $P_3(x_0 + \Delta x; y_0 + \Delta y)$ nuqtalar D to'plamga tegishli bo'lsin, bu yerda Δx , Δy – argumentlarning orttirmalari.

$\Rightarrow \Delta_x z = f(P_1) - f(P) = f(x_0 + \Delta x, y_0) - f(x_0, y_0)$ va $\Delta_y z = f(P_2) - f(P) = f(x_0, y_0 + \Delta y) - f(x_0, y_0)$ ayirmalarga $z = f(x, y)$ funktsiyaning $P_0(x_0; y_0)$ nuqtadagi x va y o'zgaruvchilar bo'yicha xususiy orttirmalari deyiladi.

$\Rightarrow \Delta z = f(P_3) - f(P) = f(x_0 + \Delta x, y_0 + \Delta y) - f(x_0, y_0)$ ayirmaga $z = f(x, y)$ funktsiyaning $P(x, y)$ nuqtadagi to'liq orttirmasi deyiladi.

1-misol. $z = xy + x^2 - y^2$ funktsiyaning $M_0(1; -1)$ nuqtadagi xususiy va to'liq orttirmalarini $\Delta x = 0,1$ va $\Delta y = -0,2$ lar uchun toping.

$$\begin{aligned} \odot \Delta_x z &= (x + \Delta x)y + (x + \Delta x)^2 - y^2 - xy - x^2 + y^2 = \\ &= (1 + 0,1) \cdot (-1) + (1 + 0,1)^2 - 1 \cdot (-1) - 1^2 = 0,01; \end{aligned}$$

$$\begin{aligned}\Delta_y z &= x(y + \Delta y) + x^2 - (y + \Delta y)^2 - xy - x^2 + y^2 = \\ &= 1 \cdot (-1 - 0,2) - (-1 - 0,2)^2 - 1 \cdot (-1) + (-1)^2 = -0,64; \\ \Delta z &= (x + \Delta x) \cdot (y + \Delta y) + (x + \Delta x)^2 - (y + \Delta y)^2 - xy - x^2 + y^2 = \\ &= (1 + 0,1) \cdot (-1 - 0,2) + (1 + 0,1)^2 - (-1 - 0,2)^2 - 1 \cdot (-1) - 1^2 + (-1)^2 = -0,55. \quad \blacktriangleleft\end{aligned}$$

☐ Agar $\frac{\Delta_x z}{\Delta x}$ nisbatining $\Delta x \rightarrow 0$ dagi limiti mavjud bo'lsa, bu limitga $z = f(x, y)$ funksiyaning $P_0(x_0; y_0)$ nuqtadagi x o'zgaruvchi bo'yicha xususiy hosilasi deyiladi va $f'_x(x_0, y_0)$ (yoki $\left(\frac{\partial z}{\partial x}\right)_{P_0}$, yoki $\left(\frac{\partial f}{\partial x}\right)_{P_0}$, yoki $z'_x(x_0, y_0)$) bilan belgilanadi:

$$f'_x(x_0, y_0) = \lim_{\Delta x \rightarrow 0} \frac{\Delta_x z}{\Delta x} = \lim_{\Delta x \rightarrow 0} \frac{f(x_0 + \Delta x, y_0) - f(x_0, y_0)}{\Delta x}.$$

$z = f(x, y)$ funksiyaning $P_0(x_0; y_0)$ nuqtadagi y o'zgaruvchi bo'yicha xususiy hosilasi

$$f'_y(x_0, y_0) = \lim_{\Delta y \rightarrow 0} \frac{\Delta_y z}{\Delta y} = \lim_{\Delta y \rightarrow 0} \frac{f(x_0, y_0 + \Delta y) - f(x_0, y_0)}{\Delta y}$$

kabi topiladi.

$n (n \geq 2)$ o'zgaruvchi funksiya-sining xususiy hosilalari ham $z = f(x, y)$ funksiyaning xususiy hosilalari kabi ta'riflanadi va belgilanadi.

⇒ Bir necha o'zgaruvchi funksiya-sining biror o'zgaruvchi bo'yicha xususiy hosilasi bu o'zgaruvchi funksiya-sining, qolgan o'zgaruvchilar o'zgarmas deb hisoblangandagi hosilasi kabi topiladi. Shu sababli bir o'zgaruvchi funksiya-sining hosilalari uchun mavjud barcha differensiallash formulalari va qoidalari bir necha o'zgaruvchi funksiya-sining xususiy hosilalari uchun ham o'rinli bo'ladi. Bunda biror argument bo'yicha xususiy hosilaning qoida va formulalarini qo'llashda qolgan argumentlarning o'zgarmas deb hisoblanishini yodda tutish lozim.

2-misol. Funktsiyalarning birinchi tartibli xususiy hosilalarini toping:

$$\begin{aligned}1) z &= \frac{x}{y^3} + \frac{y^2}{x^2} - \frac{2}{xy}; & 2) z &= \ln \operatorname{tg} \frac{u}{v}; \\ 3) u &= xyz + x^2 - y^3 + z; & 4) u &= x^{y \sin z}.\end{aligned}$$

☐ 1) y ni o'zgarmas deb, $\frac{\partial z}{\partial x}$ xususiy hosilani topamiz:

$$\frac{\partial z}{\partial x} = \frac{1}{y^3} (x)' + y^2 \left(\frac{1}{x^2}\right)' - \frac{2}{y} \left(\frac{1}{x}\right)' = \frac{1}{y^3} - \frac{2y^2}{x^3} + \frac{2}{yx^2}.$$

x ni o'zgarimas hisoblab, $\frac{\partial z}{\partial y}$ xususiy hosilani topamiz:

$$\frac{\partial z}{\partial y} = x \left(\frac{1}{y^3} \right)' + \frac{1}{x^2} (y^2)' - \frac{2}{x} \left(\frac{1}{y} \right)' = -\frac{3x}{y^4} + \frac{2y}{x^2} + \frac{2}{xy^2}.$$

$$2) \frac{\partial z}{\partial u} = \frac{1}{\operatorname{tg} \frac{u}{v}} \cdot \frac{1}{\cos^2 \frac{u}{v}} \cdot \left(\frac{u}{v} \right)'_u = \frac{2}{\sin \frac{2u}{v}} \cdot \frac{1}{v} = \frac{2}{v \sin \frac{2u}{v}},$$

$$\frac{\partial z}{\partial v} = \frac{1}{\operatorname{tg} \frac{u}{v}} \cdot \frac{1}{\cos^2 \frac{u}{v}} \cdot \left(\frac{u}{v} \right)'_v = \frac{2}{\sin \frac{2u}{v}} \cdot \left(-\frac{u}{v^2} \right) = -\frac{2u}{v^2 \sin \frac{2u}{v}}.$$

3) y va z larni o'zgarimas deb, $\frac{\partial u}{\partial x}$ xususiy hosilani topamiz:

$$\frac{\partial u}{\partial x} = yz + 2x.$$

Shu kabi topamiz:

$$\frac{\partial u}{\partial y} = xz - 3y^2, \quad \frac{\partial u}{\partial z} = xy + 1.$$

$$4) \frac{\partial u}{\partial x} = y \sin z \cdot x^{y \sin z - 1}, \quad \frac{\partial u}{\partial y} = x^{y \sin z} \ln x (y \sin z)'_y = \sin z \cdot x^{y \sin z} \ln x,$$

$$\frac{\partial u}{\partial z} = x^{y \sin z} \ln x (y \sin z)'_z = y \cos z \cdot x^{y \sin z} \ln x. \quad \ominus$$

$\Rightarrow \frac{\partial z}{\partial x} \left(\frac{\partial z}{\partial y} \right)$ xususiy hosilaning $P_0(x_0; y_0)$ nuqtadagi qiymati σ sirt bilan

$y = y_0$ ($x = x_0$) tekislik kesishish chizig'iga $M_0(x_0; y_0; z_0)$ nuqtada o'tkazilgan urinmaning Ox (Oy) o'q bilan tashkil qilgan burchagining tangensiga teng. Bu jumla $f'_x(x_0, y_0)$ ($f'_y(x_0, y_0)$) xususiy hosilaning geometrik ma'nosini bildiradi.

1.2.1. $z = f(P)$ funksiya $P(x, y)$ nuqtaning biror atrofda aniqlangan bo'lsin.

\ominus Agar $z = f(x, y)$ funksiyaning $P(x, y)$ nuqtadagi to'liq orttirmasini

$$\Delta z = A \Delta x + B \Delta y + \alpha \Delta x + \beta \Delta y$$

ko'rinishda ifodalash mumkin bo'lsa $z = f(x, y)$ funksiya $P(x, y)$ nuqtada differensiallanuvchi deyiladi, bu yerda $A, B - \Delta x, \Delta y$ ga bog'liq bo'lmagan sonlar, $\Delta x \rightarrow 0, \Delta y \rightarrow 0$ da $\alpha \rightarrow 0, \beta \rightarrow 0$.

1-teorema. Agar $z = f(x, y)$ funksiya $P(x, y)$ nuqtada differensiallanuvchi bo'lsa, u holda u shu nuqtada uzluksiz bo'ladi.

2-teorema (funksiya differensiallanuvchi bo'lishining zaruriy sharti). Agar $z = f(x, y)$ funksiya $P(x, y)$ nuqtada differensiallanuvchi bo'lsa, u holda u shu nuqtada $A = f'_x(x, y)$ va $B = f'_y(x, y)$ xususiy hosilalarga ega bo'ladi.

3-teorema (funksiya differensiallanuvchi bo'lishining yetarli sharti). Agar $z = f(x, y)$ funksiya $P(x, y)$ nuqtaning biror atrofida uzluksiz xususiy hosilalarga ega bo'lsa, u holda u shu nuqtada differensiallanuvchi bo'ladi.

$z = f(x, y)$ funksiya $P(x, y)$ nuqtada differensiallanuvchi bo'lsin.

☐ Δz to'liq orttirmaning $\Delta x, \Delta y$ larga nisbatan chiziqli bo'lgan bosh qismi $A\Delta x + B\Delta y$ ga $z = f(x, y)$ funksiyaning $P(x, y)$ nuqtadagi to'liq differensial deyiladi va u dz bilan belgilanadi:

$$dz = f'_x(x, y)dx + f'_y(x, y)dy$$

yoki

$$dz = d_x z + d_y z,$$

bu yerda $d_x z = f'_x(x, y)dx$, $d_y z = f'_y(x, y)dy$ — $z = f(x, y)$ funksiyaning $P(x, y)$ nuqtadagi xususiy differensiallari.

3-misol. Funktsiyalarning xususiy va to'liq differensiallarini toping:

$$1) z = 3^{\frac{x}{y}}; \quad 2) u = y^{\frac{x}{z^2}}.$$

☞ 1) Funktsiyaning xususiy hosilalarni topamiz:

$$\frac{\partial z}{\partial x} = 3^{\frac{x}{y}} \ln 3 \cdot \frac{1}{y}, \quad \frac{\partial z}{\partial y} = 3^{\frac{x}{y}} \ln 3 \cdot \left(-\frac{x}{y^2}\right).$$

U holda

$$d_x z = \frac{1}{y} 3^{\frac{x}{y}} \ln 3 dx, \quad d_y z = -\frac{x}{y^2} 3^{\frac{x}{y}} \ln 3 \cdot dy, \quad dz = \frac{1}{y} 3^{\frac{x}{y}} \ln 3 \cdot \left(dx - \frac{x}{y} dy\right).$$

2) Funktsiyaning xususiy hosilalarini topamiz:

$$\frac{\partial u}{\partial x} = y^{\frac{x}{z^2}} \ln y \cdot \frac{1}{z^2}, \quad \frac{\partial u}{\partial y} = \frac{x}{z^2} y^{\frac{x}{z^2}-1} = \frac{x}{yz^2} y^{\frac{x}{z^2}}, \quad \frac{\partial u}{\partial z} = y^{\frac{x}{z^2}} \ln y \cdot \left(-\frac{2x}{z^3}\right).$$

Demak,

$$d_x u = \frac{1}{z^2} y^{\frac{x}{z^2}} \ln y dx, \quad d_y u = \frac{x}{yz^2} y^{\frac{x}{z^2}} dy, \quad d_z u = -\frac{2x}{z^3} y^{\frac{x}{z^2}} \ln y dz,$$

$$du = y^{\frac{x}{z^2}} \left(\frac{1}{z^2} \ln y dx + \frac{x}{yz^2} dy - \frac{2x}{z^3} \ln y dz \right). \quad \bullet$$

⇒ Ko‘pchilik masalalarni yechishda $z = f(x, y)$ funksiyaning $P_0(x_0; y_0)$ nuqtadagi to‘liq orttirmasi funksiyaning shu nuqtadagi to‘liq differensialiga taqriban tenglashtiriladi, ya’ni $\Delta y \approx dy$ deb olinadi:

$$f(x, y) \approx f(x_0, y_0) + f'_x(x_0, y_0)\Delta x + f'_y(x_0, y_0)\Delta y. \quad (2.1)$$

Bu tenglikka ko‘ra qandaydir A kattalikning taqribiy qiymatini hisoblash quyidagi tartibda amalga oshiriladi:

1°. A ni biror $f(x, y)$ funksiyaning $P(x; y)$ nuqtadagi qiymatiga tenglashtiriladi, ya’ni $A = f(x, y)$ deb olinadi;

2°. $P_0(x_0; y_0)$ nuqta $P(x; y)$ nuqtaga yaqin va $f(x_0, y_0)$ ni hisoblash qulay qilib tanlanadi;

3°. $f(x_0, y_0)$ hisoblanadi;

4°. $f'_x(x, y), f'_y(x, y)$ lar topilib, $f'_x(x_0, y_0), f'_y(x_0, y_0)$ lar hisoblanadi;

5°. $x, y, x_0, y_0, f(x_0, y_0), f'_x(x_0, y_0), f'_y(x_0, y_0)$ qiymatlar (2.1) tenglikka qo‘yiladi.

4-misol. $\operatorname{arctg}\left(\frac{1,98}{1,03} - 1\right)$ ni taqribiy hisoblang.

⇒ 1°. $A = \operatorname{arctg}\left(\frac{1,98}{1,03} - 1\right), f(x, y) = \operatorname{arctg}\left(\frac{x}{y} - 1\right)$ deymiz.

U holda $f(x, y) = A, x = 1,98, y = 1,03$;

2°. $x_0 = 2, y_0 = 1$, ya’ni $P_0(2; 1)$ deb olamiz;

3°. $f(2, 1) = \operatorname{arctg}\left(\frac{2}{1} - 1\right) = \frac{\pi}{4} = 0,785$;

4°. $f'_x(x, y) = \frac{1}{1 + \left(\frac{x}{y} - 1\right)^2} \cdot \frac{1}{y}, f'_y(x, y) = \frac{1}{1 + \left(\frac{x}{y} - 1\right)^2} \cdot \left(-\frac{x}{y^2}\right)$,

$f'_x(2, 1) = \frac{1}{2} = 0,5, f'_y(2, 1) = -1$;

5°. $\operatorname{arctg}\left(\frac{1,98}{1,03} - 1\right) \approx 0,785 + 0,5 \cdot (1,98 - 2) - 1 \cdot (1,03 - 1) = 0,745.$ ◀

◻ **1.2.3.** Sirtga $M_0(x_0; y_0; z_0)$ nuqtada o‘tkazilgan *urinma tekislik* deb sirtning bu nuqtasi orqali o‘tgan barcha egri chiziq'larga o‘tkazilgan urinmalar joylashgan tekislikka aytiladi.

☐ $M_0(x_0; y_0; z_0)$ nuqtada o'tkazilgan urinma tekislikka perpendikulyar bo'lgan to'g'ri chiziq sirtga shu nuqtada o'tkazilgan *normal* deb ataladi.

$z = f(x, y)$ funksiya bilan berilgan sirtning $M_0(x_0; y_0; z_0)$ nuqtasiga o'tkazilgan urinma tekislik va normal mos ravishda

$$z - z_0 = f'_x(x_0, y_0)(x - x_0) + f'_y(x_0, y_0)(y - y_0), \quad (2.2)$$

$$\frac{x - x_0}{f'_x(x_0, y_0)} = \frac{y - y_0}{f'_y(x_0, y_0)} = \frac{z - z_0}{-1} \quad (2.3)$$

tenglamalar bilan aniqlanadi.

Agar sirt $F(x, y, z) = 0$ tenglama bilan oshkormas ko'rinishda berilsa, bu sirtning $M_0(x_0; y_0; z_0)$ nuqtasiga o'tkazilgan urinma tekislik va normal

$$F'_x(x_0, y_0, z_0)(x - x_0) + F'_y(x_0, y_0, z_0)(y - y_0) + F'_z(x_0, y_0, z_0)(z - z_0) = 0 \quad (2.4)$$

$$\frac{x - x_0}{F'_x(x_0, y_0, z_0)} = \frac{y - y_0}{F'_y(x_0, y_0, z_0)} = \frac{z - z_0}{F'_z(x_0, y_0, z_0)} \quad (2.5)$$

tenglamalar bilan topiladi.

5-misol. $x^2 + 3y^2 - 2z^2 = 4$ giperboloidga $M_0(-3; -1; 2)$ nuqtada o'tkazilgan urinma tekislik va normal tenglamalarini tuzing.

☞ $F(x, y, z) = x^2 + 3y^2 - 2z^2 - 4 = 0$ belgilash kiritamiz.

U holda

$$F'_x(M_0) = 2x_0 = 2(-3) = -6, \quad F'_y(M_0) = 6y_0 = -6, \quad F'_z(M_0) = -4z_0 = -8.$$

Bu qiymatlarni (2.4) va (2.5) tenglamalarga qo'yib, topamiz:

1) urinma tekislik tenglamasi

$$-6(x + 3) - 6(y + 1) - 8(z - 2) = 0$$

yoki

$$3x + 3y + 4z + 4 = 0;$$

2) normal tenglamasi

$$\frac{x + 3}{3} = \frac{y + 1}{3} = \frac{z - 2}{4}. \quad \text{☞}$$

☞ $z = f(x, y)$ funksiyaning $P_0(x_0; y_0)$ nuqtadagi dz to'liq differensialini $z = f(x, y)$ sirtga uning $M_0(x_0; y_0; z_0)$ nuqtasida o'tkazilgan urinma tekislik urinish nuqtasi applikatasining orttirmasiga teng. Bu jumla *to'liq differensialning geometrik ma'nosini* ifodalaydi.

1.2.4. Biror D sohada ikki o'zgaruvchining $z = f(x, y)$ funksiyasi berilgan bo'lib, bunda $x = x(t)$, $y = y(t)$, ya'ni x va y o'zgaruvchilar qandaydir t o'zgaruvchining funksiyalari bo'lsin.

4-teorema. Agar $z = f(x, y)$ funksiya $P(x, y) \in D$ nuqtada differensiallanuvchi bo'lib, $x = x(t)$, $y = y(t)$ – bog'liqmas o'zgaruvchining differensiallanuvchi funksiyalari bo'lsa, u holda $z = f(x(t), y(t))$ murakkab funksiyaning $P(x, y)$ nuqtadagi xususiy hosilasi

$$\frac{dz}{dt} = \frac{\partial z}{\partial x} \frac{dx}{dt} + \frac{\partial z}{\partial y} \frac{dy}{dt} \quad (2.6)$$

formula bilan aniqlanadi.

Xususan, $z = f(x, y)$, $y = y(x)$ bo'lsa

$$\frac{dz}{dx} = \frac{\partial z}{\partial x} + \frac{\partial z}{\partial y} \frac{dy}{dx} \quad (2.7)$$

bo'ladi.

(2.7) formula x bo'yicha *to'liq differensial formulasi* deb ataladi.

6-misol. $z = \arctg \frac{x}{y}$, $x = sht$, $y = cht$ funksiya berilgan. $\frac{dz}{dt}$ ni toping.

☉ Funksiyalarning hosilalarini topamiz:

$$\frac{\partial z}{\partial x} = \frac{1}{1 + \left(\frac{x}{y}\right)^2} \cdot \frac{1}{y} = \frac{y}{x^2 + y^2}, \quad \frac{\partial z}{\partial y} = \frac{1}{1 + \left(\frac{x}{y}\right)^2} \cdot \left(-\frac{x}{y^2}\right) = -\frac{x}{x^2 + y^2},$$

$$\frac{dx}{dt} = cht, \quad \frac{dy}{dt} = sht.$$

U holda (2.6) formulaga ko'ra

$$\frac{dz}{dt} = \frac{\partial z}{\partial x} \frac{dx}{dt} + \frac{\partial z}{\partial y} \frac{dy}{dt} = \frac{y}{x^2 + y^2} \cdot cht - \frac{x}{x^2 + y^2} \cdot sht = \frac{ycht - xsht}{x^2 + y^2}.$$

x va y ni t orqali ifodalab, topamiz:

$$\frac{dz}{dt} = \frac{cht \cdot cht - sht \cdot sht}{sh^2 t + ch^2 t} = \frac{1}{ch2t}. \quad \text{☉}$$

7-misol. $z = \ln(x^2 + y)$, $y = 3e^{\frac{x^2}{2}} - x^2$ funksiya berilgan. $\frac{dz}{dx}$ ni toping.

☉ (2.7) formuladan topamiz:

$$\frac{dz}{dx} = \frac{\partial z}{\partial x} + \frac{\partial z}{\partial y} \frac{dy}{dx} = \frac{2x}{x^2 + y} + \frac{1}{x^2 + y} \left(3xe^{\frac{x^2}{2}} - 2x \right) = \frac{3xe^{\frac{x^2}{2}}}{x^2 + y}.$$

$y = y(x)$ ni o'rniga qo'yamiz:

$$\frac{dz}{dx} = \frac{3xe^{\frac{x^2}{2}}}{x^2 + 3e^{\frac{x^2}{2}} - x^2} = x. \quad \odot$$

Biror D sohada ikki o'zgaruvchining $z = f(x, y)$ funksivasi berilgan bo'lib, bunda $x = x(u, v)$, $y = y(u, v)$, ya'ni x va y o'zgaruvchilar ikkita u va v o'zgaruvchilarning funksiyalari bo'lsin.

5-teorema. Agar $z = f(x, y)$, $x = x(u, v)$, $y = y(u, v)$ funksiyalar o'z argumentlarining differensiallanuvchi funksiyalari bo'lsa, u holda $z = f(x(u, v), y(u, v))$ murakkab funksiyaning $P(x, y)$ nuqtadagi xususiy hosilalari

$$\frac{\partial z}{\partial u} = \frac{\partial z}{\partial x} \frac{\partial x}{\partial u} + \frac{\partial z}{\partial y} \frac{\partial y}{\partial u}, \quad \frac{\partial z}{\partial v} = \frac{\partial z}{\partial x} \frac{\partial x}{\partial v} + \frac{\partial z}{\partial y} \frac{\partial y}{\partial v} \quad (2.8)$$

formular bilan topiladi.

\Rightarrow (z) murakkab funksiyaning har bir bog'liqmas o'zgaruvchi (u va v) bo'yicha xususiy hosilasi bu (z) funksiyaning oraliq o'zgaruvchilar (x va y) bo'yicha xususiy hosilalari bilan mos bog'liqmas o'zgaruvchi (u va v) bo'yicha xususiy hosilalar ko'paytmasining yig'indisiga teng bo'ladi.

\Rightarrow Murakkab funksiyaning to'liq differensiali invariantlik xossasiga ega: $z = f(x, y)$ murakkab funksiyaning to'liq differensiali argumenti bog'liqmas o'zgaruvchi bo'lganida ham, bog'liqmas o'zgaruvchining funksiyasi bo'lganida ham bir xil ko'rinishda bo'ladi.

8-misol. $z = \arcsin \frac{x}{y}$, $x = u \sin v$, $y = u \operatorname{tg} v$ funksiya berilgan.

$\frac{\partial z}{\partial u}$, $\frac{\partial z}{\partial v}$, dz larni toping.

\odot Funksiyalarning xususiy hosilalarini topamiz:

$$\frac{\partial z}{\partial x} = \frac{1}{\sqrt{y^2 - x^2}}, \quad \frac{\partial z}{\partial y} = -\frac{x}{y\sqrt{y^2 - x^2}},$$

$$\frac{\partial x}{\partial u} = \sin v, \quad \frac{\partial y}{\partial u} = \operatorname{tg} v, \quad \frac{\partial x}{\partial v} = u \cos v, \quad \frac{\partial y}{\partial v} = \frac{u}{\cos^2 v}.$$

U holda

$$\frac{\partial z}{\partial u} = \frac{\partial z}{\partial x} \frac{\partial x}{\partial u} + \frac{\partial z}{\partial y} \frac{\partial y}{\partial u} = \frac{1}{\sqrt{y^2 - x^2}} \cdot \sin v - \frac{x}{y\sqrt{y^2 - x^2}} \cdot \operatorname{tg} v = \frac{\operatorname{tg} v (y \cos v - x)}{y\sqrt{y^2 - x^2}}$$

yoki

$$\frac{\partial z}{\partial u} = \frac{\operatorname{tg} v (utgv \cos v - u \sin v)}{utgv \sqrt{(utgv)^2 - (u \sin v)^2}} = 0.$$

Shu kabi

$$\frac{\partial z}{\partial v} = \frac{\partial z}{\partial x} \frac{\partial x}{\partial v} + \frac{\partial z}{\partial y} \frac{\partial y}{\partial v} = \frac{1}{\sqrt{y^2 - x^2}} \cdot u \cos v - \frac{x}{y \sqrt{y^2 - x^2}} \cdot \frac{u}{\cos^2 v} = \frac{u(y \cos^3 v - x)}{\cos^2 v \cdot y \sqrt{y^2 - x^2}}$$

yoki

$$\frac{\partial z}{\partial v} = \frac{u(utgv \cos^3 v - u \sin v)}{\cos^2 v \cdot utgv \sqrt{(utgv)^2 - (u \sin v)^2}} = -1.$$

Bundan

$$dz = \frac{\partial z}{\partial u} du + \frac{\partial z}{\partial v} dv = 0 \cdot du + (-1) \cdot dv = -dv. \quad \ominus$$

9-misol. $u = \ln(x^2 + y^2 - z^2)$, $x = \sin t$, $y = t + \cos t$, $z = t$ bo'lsa, $\frac{du}{dt}$ ni

toping.

☉ Funktsiyalarning xususiy hosilalarini topamiz:

$$\frac{\partial u}{\partial x} = \frac{2x}{x^2 + y^2 - z^2}, \quad \frac{\partial u}{\partial y} = \frac{2y}{x^2 + y^2 - z^2}, \quad \frac{\partial u}{\partial z} = -\frac{2z}{x^2 + y^2 - z^2},$$

$$\frac{dx}{dt} = \cos t, \quad \frac{dy}{dt} = 1 - \sin t, \quad \frac{dz}{dt} = 1.$$

U holda

$$\frac{du}{dt} = \frac{\partial u}{\partial x} \frac{dx}{dt} + \frac{\partial u}{\partial y} \frac{dy}{dt} + \frac{\partial u}{\partial z} \frac{dz}{dt} = \frac{2}{x^2 + y^2 - z^2} (x \cos t + y \cdot (1 - \sin t) - z).$$

x , y va z ni t orqali ifodalab, topamiz:

$$\frac{du}{dt} = 2 \frac{\sin t \cos t + (t + \cos t)(1 - \sin t) - t}{\sin^2 t + (t + \cos t)^2 - t^2} = \frac{2(\cos t - t \sin t)}{1 + 2t \cos t}. \quad \ominus$$

☑ **1.2.5.** Agar x ning X to'plamidagi har bir qiymatiga $F(x, y) = 0$ tenglamani x bilan birgalikda qanoatlantiruvchi yagona y qiymat mos qo'yilsa, X to'plamda $F(x, y) = 0$ tenglama bilan $y = f(x)$ oshkormas funksiya aniqlangan deyiladi.

Masalan, $3^y - 2x^2 - 1 = 0$ tenglama butun sonlar o'qida x ga nisbatan y funksiyani oshkormas aniqlaydi, chunki x va y ning bu tenglamani qanoatlantiradigan qiymatlar juftliklari mavjud ((0;0), (2;2) va hokazo).

6-teorema (*oshkormas funksiyaning mavjudlik teoremasi*). Agar $F(x, y)$ funksiya $F'_x(x, y), F'_y(x, y)$ xususiy hosilalari bilan birgalikda $P_0(x_0; y_0)$ nuqtaning biror atrofida aniqlangan va uzluksiz bo'lib, $F(x_0, y_0) = 0$, $F'_y(x_0, y_0) \neq 0$ bo'lsa, u holda $F(x, y) = 0$ tenglama bu atrofda x_0 nuqtani o'z ichiga olgan qandaydir oraliqda uzluksiz va differentsiallanuvchi yagona $y = f(x)$ (bunda $y_0 = f(x_0)$ bo'ladi) oshkormas funksiyani aniqlaydi.

$F(x, y) = 0$ tenglama $y = f(x)$ oshkormas funksiyani aniqlasa, $y = f(x)$ funksiyaning hosilasi

$$\frac{dy}{dx} = -\frac{F'_x(x, y)}{F'_y(x, y)} \quad (2.9)$$

formula bilan topiladi.

$F(x, y, z) = 0$ tenglama $z = f(x, y)$ oshkormas funksiyani aniqlasa, $z = f(x, y)$ funksiyaning x va y o'zgaruvchilar bo'yicha xususiy hosilalari

$$\frac{\partial z}{\partial x} = -\frac{F'_x(x, y, z)}{F'_z(x, y, z)}, \quad \frac{\partial z}{\partial y} = -\frac{F'_y(x, y, z)}{F'_z(x, y, z)}. \quad (2.10)$$

tengliklar bilan aniqlanadi.

10-misol. $x \sin y - ye^{2x} - 10 = 0$ tenglama bilan oshkormas ko'rinishda berilgan $y = f(x)$ funksiyaning hosilasini toping.

☞ Tenglamaning chap tomonini $F(x, y)$ orqali belgilaymiz va uning xususiy hosilalarini topamiz:

$$F'_x(x, y) = \sin y - 2ye^{2x}, \quad F'_y(x, y) = x \cos y - e^{2x}.$$

Demak,

$$\frac{dy}{dx} = -\frac{F'_x(x, y)}{F'_y(x, y)} = \frac{2ye^{2x} - \sin y}{x \cos y - e^{2x}}. \quad \text{☞}$$

11-misol. $\sin(x+z) - \frac{xz}{y} = 0$ tenglama bilan oshkormas ko'rinishda berilgan $z = f(x, y)$ funksiyaning birinchi tartibli xususiy hosilalarini toping.

☞ Misolning shartiga ko'ra $F(x, y, z) = \sin(x+z) - \frac{xz}{y}$.

Bundan

$$F'_x(x, y, z) = \cos(x+z) - \frac{z}{y} = \frac{y \cos(x+z) - z}{y},$$

$$F'_y(x, y, z) = \frac{xz}{y^2}; \quad F'_z(x, y, z) = \cos(x+z) - \frac{x}{y} = -\frac{x - y \cos(x+z)}{y}.$$

U holda

$$\frac{\partial z}{\partial x} = -\frac{F'_x(x, y, z)}{F'_z(x, y, z)} = \frac{y \cos(x+z) - z}{x - y \cos(x+z)},$$

$$\frac{\partial z}{\partial y} = -\frac{F'_y(x, y, z)}{F'_z(x, y, z)} = \frac{xz}{y \cdot (x - y \cos(x+z))}. \quad \ominus$$

1.2.6. $\frac{\partial z}{\partial x} = f'_x(x, y)$ va $\frac{\partial z}{\partial y} = f'_y(x, y)$ hosilalarga $z = f(x, y)$ funksiyaning $P(x; y)$ nuqtadagi *birinchi tartibli xususiy hosilalari* deyiladi.

Bu hosilalar x va y o'zgaruvchilarning xususiy hosilalariga ega bo'lsa, ularga *ikkinchi tartibli xususiy hosilalar* deyiladi va quyidagicha belgilanadi:

$$\frac{\partial}{\partial x} \left(\frac{\partial z}{\partial x} \right) = \frac{\partial^2 z}{\partial x^2} = z''_{xx} = f''_{x^2}(x, y); \quad \frac{\partial}{\partial x} \left(\frac{\partial z}{\partial y} \right) = \frac{\partial^2 z}{\partial y \partial x} = z''_{xy} = f''_{xy}(x, y);$$

$$\frac{\partial}{\partial y} \left(\frac{\partial z}{\partial x} \right) = \frac{\partial^2 z}{\partial x \partial y} = z''_{yx} = f''_{yx}(x, y); \quad \frac{\partial}{\partial y} \left(\frac{\partial z}{\partial y} \right) = \frac{\partial^2 z}{\partial y^2} = z''_{yy} = f''_{y^2}(x, y).$$

Uchinchi, to'rtinchi va umuman n -tartibli xususiy hosilalar shu kabi aniqlanadi.

\Rightarrow $f''_{xy}(x, y)$ va $f''_{yx}(x, y)$ hosilalarga *ikkinchi tartibli aralash xususiy hosilalar* deyiladi. Agar $z = f(x, y)$ funksiyaning ikkinchi tartibli aralash xususiy hosilalari $P(x; y)$ nuqtaning biror atrofida mavjud va shu nuqtada uzluksiz bo'lsa, shu nuqtada $f''_{xy}(x, y) = f''_{yx}(x, y)$ bo'ladi.

Bunday tasdiq istalgan yuqori tartibli xususiy hosilalar uchun ham o'rinli bo'ladi. Masalan, uzluksiz uchinchi tartibli xususiy hosilalar uchun

$$f'''_{xyx}(x, y, z) = f'''_{x^2y}(x, y, z) = f'''_{yx^2}(x, y, z).$$

12-misol. $z = \arctg \frac{x}{y}$ funksiyaning barcha birinchi va ikkinchi tartibli xususiy hosilalarini toping.

\Rightarrow Birinchi tartibli xususiy hosilalarni topamiz:

$$\frac{\partial z}{\partial x} = \frac{1}{1 + \left(\frac{x}{y}\right)^2} \cdot \frac{1}{y} = \frac{y}{x^2 + y^2}, \quad \frac{\partial z}{\partial y} = \frac{1}{1 + \left(\frac{x}{y}\right)^2} \cdot \left(-\frac{x}{y^2}\right) = -\frac{x}{x^2 + y^2}.$$

Ikkinchi tartibli xususiy hosilalarni topamiz:

$$\frac{\partial^2 z}{\partial x^2} = \frac{\partial}{\partial x} \left(\frac{y}{x^2 + y^2} \right) = -\frac{2xy}{(x^2 + y^2)^2},$$

$$\frac{\partial^2 z}{\partial x \partial y} = \frac{\partial}{\partial y} \left(\frac{y}{x^2 + y^2} \right) = \frac{x^2 + y^2 - 2y \cdot y}{(x^2 + y^2)^2} = \frac{x^2 - y^2}{(x^2 + y^2)^2},$$

$$\frac{\partial^2 z}{\partial y^2} = \frac{\partial}{\partial y} \left(-\frac{x}{x^2 + y^2} \right) = \frac{2xy}{(x^2 + y^2)^2}. \quad \ominus$$

$dz = f'_x(x, y)dx + f'_y(x, y)dy$ differensialga $z = f(x, y)$ funksiyaning $P(x, y)$ nuqtadagi *birinchi tartibli to'liq differensial* deyiladi. Agar $z = f(x, y)$ funksiya $P(x, y)$ nuqtada ikkinchi tartibli uzluksiz xususiy hosilalarga ega bo'lsa, *ikkinchi tartibli to'liq differensial* $d^2z = d(dz)$ kabi aniqlanadi:

$$d^2z = f''_{xx}(x, y)dx^2 + 2f''_{xy}(x, y)dydx + f''_{yy}dy^2, \quad (2.11)$$

bu yerda $dx^2 = (dx)^2$, $dy^2 = (dy)^2$.

(2.11) formula simvolik ko'rinishda

$$d^2z = \left(\frac{\partial}{\partial x} dx + \frac{\partial}{\partial y} dy \right)^2 \cdot z$$

kabi yoziladi.

Uchinchi tartibli to'liq differensial shu kabi ta'riflanadi va aniqlanadi:

$$d^3z = f'''_{xxx}(x, y)dx^3 + 3f'''_{x^2y}(x, y)dx^2dy + 3f'''_{xy^2}(x, y)dxdy^2 + f'''_{yyy}(x, y)dy^3 \quad (2.12)$$

yoki

$$d^3z = \left(\frac{\partial}{\partial x} dx + \frac{\partial}{\partial y} dy \right)^3 \cdot z.$$

n – tartibli to'liq differensial uchun

$$d^n z = \left(\frac{\partial}{\partial x} dx + \frac{\partial}{\partial y} dy \right)^n \cdot z, \quad n \in \mathbb{N}$$

formula o'rinli bo'ladi. Bunda $z = f(x, y)$ funksiyaning x va y o'zgaruvchilari bo'g'liqmas bo'lishi lozim.

13-misol. $z = x \sin y - y \cos x$ funksiyaning birinchi va ikkinchi tartibli to'liq differensiallarini toping.

☉ Birinchi tartibli xususiy hosilalarni topamiz:

$$\frac{\partial z}{\partial x} = \sin y + y \sin x, \quad \frac{\partial z}{\partial y} = x \cos y - \cos x.$$

Bundan

$$dz = (\sin y + y \sin x)dx + (x \cos y - \cos x)dy.$$

Ikkinchi tartibli xususiy hosilalarni topamiz:

$$\frac{\partial^2 z}{\partial x^2} = \frac{\partial}{\partial x}(\sin y + y \sin x) = y \cos x, \quad \frac{\partial^2 z}{\partial x \partial y} = \frac{\partial}{\partial y}(\sin y + y \cos x) = \cos y + \sin x,$$

$$\frac{\partial^2 z}{\partial y^2} = \frac{\partial}{\partial y}(x \cos y - \cos x) = -x \sin y.$$

Demak,

$$d^2 z = y \cos x d^2 x + 2(\cos y + \sin x) dx dy - x \sin y d^2 y. \quad \odot$$

Mustahkamlash uchun mashqlar

1.2.1. $z = x^2 - xy + y^2$ funksiyaning $M_0(2;1)$ nuqtadagi xususiy va to‘liq orttirmalarini $\Delta x = 0,1$ va $\Delta y = 0,2$ lar uchun toping.

1.2.2. $z = xy^2 + yx^2$ funksiyaning $M_0(2;1)$ nuqtadagi xususiy va to‘liq orttirmalarini $\Delta x = -0,2$ va $\Delta y = 0,1$ lar uchun toping.

1.2.3. Funktsiyalarning birinchi tartibli xususiy hosilalarini toping:

1) $z = x^4 - 4x^2 y^3 + y^4;$

2) $z = xy + \frac{y}{x};$

3) $z = y\sqrt{x} + \frac{x}{\sqrt[3]{y}};$

4) $z = \frac{xy}{x-y};$

5) $z = \arcsin \frac{y}{\sqrt{x^2 + y^2}};$

6) $z = \operatorname{arctg} \frac{y}{x^2};$

7) $z = xe^{-\frac{y}{x}};$

8) $z = (5 + xy)^x;$

9) $z = \ln \sin(x - 2y);$

10) $z = \ln(x^2 + e^{-y});$

11) $z = e^{\frac{y}{x}} \ln y;$

11) $z = y^{xy};$

13) $u = x^4 + yz^2 + 3xz - xy;$

14) $u = e^{xyz} + y^3 - 5z^4;$

15) $u = (\cos x)^{yz};$

16) $u = z^{\frac{y}{x}}.$

1.2.4. Funktsiyalarning xususiy va to‘liq differensiallarini toping:

1) $z = x^{y^2};$

2) $z = \sin x + \ln(x^3 + y^3).$

1.2.5. Funktsiyalarning to‘liq differensialini toping:

1) $u = \frac{z}{x^2 + y^2};$

2) $u = y^{xz}.$

1.2.6. Funktsiyalarning berilgan nuqtalardagi taqribiy qiymatini hisoblang:

1) $z = \sqrt[3]{2x^2 + 6y}$, $M_0(0,97;0,98)$;

2) $z = e^y \ln(x + 2y)$, $M_0(0,98;0,03)$.

1.2.7. Taqribiy hisoblang:

1) $\sqrt{1.03^2 + 1.98^3}$;

2) $\frac{1.03^2}{\sqrt[3]{0.98^4} \sqrt{1.05^3}}$.

1.2.8. $z = \operatorname{arctg} \frac{x}{y}$, $x = e^{2t} - 1$, $y = e^{2t} + 1$ funksiya berilgan. $\frac{dz}{dt}$ ni toping.

1.2.9. $z = x^2 + xy + y^2$, $x = \sin t$, $y = e^t$ funksiya berilgan. $\frac{dz}{dt}$ ni toping.

1.2.10. $u = \ln(x^2 + y^2 + z)$, $x = t \sin t$, $y = t \cos t$, $z = t^2$ funksiya berilgan.

$\frac{du}{dt}$ ni toping.

1.2.11. $u = x^3 y^2 z$, $x = e^t$, $y = \sqrt{1+t}$, $z = t$ funksiya berilgan. $\frac{du}{dt}$ ni toping.

1.2.12. $z = \arcsin \frac{x}{y}$, $y = \sqrt{1+x^2}$ funksiya berilgan. $\frac{dz}{dx}$ ni toping.

1.2.13. $z = \ln(x^2 + y^2)$, $y = x \operatorname{tg} x$ funksiya berilgan. $\frac{dz}{dx}$ ni toping.

1.2.14. $z = xy^3 + yx^3$, $x = u \sin v$, $y = u \cos v$ funksiya berilgan.

$\frac{\partial z}{\partial u}$ va $\frac{\partial z}{\partial v}$ ni toping.

1.2.15. $z = \frac{x}{y}$, $x = e^u - 2e^v$, $y = 2e^u + e^v$ funksiya berilgan.

$\frac{\partial z}{\partial u}$ va $\frac{\partial z}{\partial v}$ ni toping.

1.2.16. $z = \ln(u^2 + v^2 + w^2)$, $u = x + y$, $v = x - y$, $w = 2\sqrt{xy}$ funksiya berilgan.

$\frac{\partial z}{\partial x}$ va $\frac{\partial z}{\partial y}$ ni toping.

1.2.17. $z = \operatorname{arctg} \frac{u \cdot v}{w}$, $u = x$, $v = \cos y$, $w = x \sin y$ funksiya berilgan.

$\frac{\partial z}{\partial x}$ va $\frac{\partial z}{\partial y}$ ni toping.

1.3. BIR NECHA O‘ZGARUVCHINING FUNKSIYASINI EKSTREMUMGA TEKSHIRISH

Ikki o‘zgaruvchi funksiyasining ekstremumlari. Ikki o‘zgaruvchi funksiyasining yopiq sohadagi eng katta va eng kichik qiymatlari. Shartli ekstremum

1.3.1. $z = f(x, y)$ funksiya biror D sohada aniqlangan va $P_0(x_0; y_0) \in D$ bo‘lsin.

☐ Agar $P_0(x_0; y_0)$ nuqtaning shunday δ –atrofi topilsaki, bu atrofning barcha $P_0(x_0; y_0)$ nuqtadan farqli $P(x; y)$ nuqtalarida $f(x, y) < f(x_0, y_0)$ ($f(x, y) > f(x_0, y_0)$) tengsizlik bajarilsa, $P_0(x_0; y_0)$ nuqtaga $f(x, y)$ funksiyaning *maksimum (minimum)* nuqtasi deyiladi.

Funksiyaning maksimum va minimum nuqtalariga *ekstremum* nuqtalar deyiladi. Funksiyaning ekstremum nuqtadagi qiymati *funksiyaning ekstremumi* deb ataladi.

1-teorema (*ekstremum mavjud bo‘lishining zaruriy sharti*). Agar $z = f(x, y)$ funksiya $P_0(x_0; y_0)$ nuqtada ekstremumga ega bo‘lsa, u holda bu nuqtada $\frac{\partial z}{\partial x}$ va $\frac{\partial z}{\partial y}$ hosilalar nolga teng bo‘ladi yoki ulardan hech bo‘lmaganda bittasi mavjud bo‘lmaydi.

Xususiy hosilalar nolga teng bo‘ladigan nuqtalarga *statsionar nuqtalar* deyiladi.

Xususiy nolga teng bo‘ladigan yoki ulardan hech bo‘lmaganda bittasi mavjud bo‘lmagan nuqtalarga *kritik nuqtalar* deyiladi.

2-teorema (*ekstremum mavjud bo‘lishining yetarli sharti*). $z = f(x, y)$ funksiyaning $P_0(x_0; y_0)$ statsionar nuqtaning biror atrofida birinchi va ikkinchi tartibli uzluksiz xususiy hosilalari mavjud va bunda $f''_{x^2}(x_0, y_0) = A$, $f''_{xy}(x_0, y_0) = B$, $f''_{y^2}(x_0, y_0) = C$ bo‘lsin. U holda

a) agar $\Delta = AC - B^2 > 0$ bo‘lsa, $z = f(x, y)$ funksiya $P_0(x_0; y_0)$ nuqtada ekstremumga ega bo‘lib, bunda $A < 0$ (yoki $C < 0$) bo‘lganda $P_0(x_0; y_0)$ nuqta maksimum nuqta, $A > 0$ (yoki $C > 0$) bo‘lganda $P_0(x_0; y_0)$ nuqta minimum nuqta bo‘ladi;

b) agar $\Delta = AC - B^2 < 0$ bo‘lsa, $P_0(x_0; y_0)$ nuqtada ekstremum mavjud bo‘lmaydi;

c) agar $\Delta = AC - B^2 = 0$ bo'lsa, $P_0(x_0; y_0)$ nuqtada ekstremum mavjud bo'lishi ham, mavjud bo'lmisligi ham mumkin (bu holda qo'shimcha tekshirishlar o'tkaziladi).

⇒ Ekstremum mavjud bo'lishining zaruriy va yetarli shartlariga asoslangan $z = f(x, y)$ funksiyani ekstremumga tekshirish tartibi:

1°. $\frac{\partial z}{\partial x}, \frac{\partial z}{\partial y}$ xususiy hosilalar topiladi;

2°. Statsionar nuqtalar aniqlanadi;

3°. $\frac{\partial^2 z}{\partial x^2}, \frac{\partial^2 z}{\partial y^2}, \frac{\partial^2 z}{\partial x \partial y}$ xususiy hosilalar topiladi;

4°. $A = \frac{\partial^2 z}{\partial x^2}, C = \frac{\partial^2 z}{\partial y^2}, B = \frac{\partial^2 z}{\partial x \partial y}$ xususiy hosilalarning statsionar

nuqtalardagi qiymatlari hisoblanadi;

5°. Har bir statsionar nuqtada $\Delta = AC - B^2$ ning qiymati hisoblanadi va 1-teorema asosida xulosa chiqariladi.

1-misol. Funksiyalarni ekstremumga tekshiring.

$$1) z = \frac{x^2 - 2x + y^2}{y};$$

$$2) z = x^2 + 2y^2 - 2x + 4y - 3;$$

$$3) z = x^2 - y^2;$$

$$4) z = 3x^2y - x^3 - y^4.$$

⇒ Funksiyalarni ekstremumga belgilangan tartibda tekshiramiz.

1) 1°. Funksiyaning birinchi tartibli xususiy hosilalarini topamiz:

$$\frac{\partial z}{\partial x} = \frac{2x - 2}{y}, \quad \frac{\partial z}{\partial y} = \frac{y^2 - x^2 + 2x}{y^2}.$$

2°. Statsionar nuqtalarni aniqlaymiz:

$$\begin{cases} 2(x - 1) = 0, \\ y^2 - x^2 + 2x = 0 \end{cases} \Rightarrow \begin{cases} x = 1, \\ y^2 = -1. \end{cases}$$

Sistema yechimga ega emas. Demak, funksiya ekstremum nuqtaga ega emas.

$$2) 1°. \frac{\partial z}{\partial x} = 2x - 2, \quad \frac{\partial z}{\partial y} = 4y + 4.$$

$$2°. \begin{cases} 2(x - 1) = 0, \\ 4(y + 1) = 0 \end{cases}$$

sistemani yechib, statsionar nuqtani topamiz: $P(1; -1)$.

3°. Ikkinchi tartibli xususiy hosilalarni topamiz:

$$\frac{\partial^2 z}{\partial x^2} = 2, \quad \frac{\partial^2 z}{\partial x \partial y} = 0, \quad \frac{\partial^2 z}{\partial y^2} = 4.$$

4°. Barcha nuqtalarda, jumladan $P(1;-1)$ nuqtada $A = 2$, $B = 0$, $C = 4$.

5°. $\Delta = AC - B^2 = 2 \cdot 4 = 8 > 0$, bunda $A > 0$. Demak, $P(1;-1)$ nuqta minimum nuqta va $z_{\min} = z(1;-1) = 1^2 + 2 \cdot (-1)^2 - 2 \cdot 1 + 4 \cdot (-1) - 3 = -6$.

3) 1°. $\frac{\partial z}{\partial x} = 2x$, $\frac{\partial z}{\partial y} = -2y$.

2°. Demak, $P(0;0)$ – statsionar nuqta.

3°. $\frac{\partial^2 z}{\partial x^2} = 2$, $\frac{\partial^2 z}{\partial x \partial y} = 0$, $\frac{\partial^2 z}{\partial y^2} = -2$.

4°. Bundan $A = 2$, $B = 0$, $C = -2$.

5°. $\Delta = AC - B^2 = -4 < 0$. Demak, $P(0;0)$ nuqtada ekstremum mavjud emas.

4) 1°. $\frac{\partial z}{\partial x} = 6xy - 3x^2$, $\frac{\partial z}{\partial y} = 3x^2 - 4y^3$.

2°.
$$\begin{cases} 3x(2y - x) = 0, \\ 3x^2 - 4y^3 = 0 \end{cases}$$

sistemani yechib, statsionar nuqtalarni topamiz. Ular ikkita: $P_1(6;3)$, $P_2(0;0)$.

3°. $\frac{\partial^2 z}{\partial x^2} = 6y - 6x$, $\frac{\partial^2 z}{\partial x \partial y} = 6x$, $\frac{\partial^2 z}{\partial y^2} = -12y^2$.

4°. Har bir statsionar nuqtada ikkinchi tartibli xususiy hosilalarni hisoblaymiz:

1) $P_1(6;3)$ nuqtada $A_1 = -18$, $B_1 = 36$, $C_1 = -108$;

2) $P_2(0;0)$ nuqtada $A_2 = 0$, $B_2 = 0$, $C_2 = 0$.

5°. Har bir statsionar nuqtada $\Delta = AC - B^2$ diskriminantni hisoblaymiz va 1-teorema asosida xulosa chiqaramiz:

1) $\Delta_1 = A_1 C_1 - B_1^2 = 648 > 0$, bunda $A_1 < 0$ Demak, $P_1(6;3)$ nuqta maksimum nuqta va $z_{\max} = 3 \cdot 36 \cdot 3 - 6^3 - 3^4 = 27$;

2) $\Delta_2 = A_2 C_2 - B_2^2 = 0$.

Qo‘shimcha tekshirish bajaramiz: z funksiya $P_2(0;0)$ nuqtada nolga teng; $x = 0$, $y \neq 0$ da manfiy ($z = -y^4 < 0$); $x < 0$, $y = 0$ da musbat ($z = -x^3 > 0$).

Demak, $P_2(0;0)$ nuqtada ekstremum mavjud emas. 

 **1.3.2** Chegaralangan yopiq D sohada differensiallanuvchi $z = f(x, y)$ funksiyaning eng katta va eng kichik qiymatlari quyidagi tartibda topiladi:

1°. Sohaning ichida yotgan barcha kritik nuqtalar topiladi va funksiyaning bu nuqtalardagi qiymatlari hisoblanadi;

2°. Funksiyaning soha chegarasidagi eng katta va eng kichik qiymatlari hisoblanadi (ayrim hollarda D sohaning chegarasi alohida tenglamalar bilan berilgan qismlarga ajratilishi mumkin);

3°. Funksiyaning barcha hisoblangan qiymatlari solishtiriladi va ularning eng katta va eng kichigi ajratiladi.

2-misol. $z = \sin x + \sin y - \sin(x + y)$ funksiyaning $x = 0$, $y = 0$ va $x + y - 2\pi = 0$ to'g'ri chiziqlar bilan chegaralangan D sohadagi (3-shakl) eng katta va eng kichik qiymatlarini toping.

☞ 1°. Funksiyaning D sohada yotgan kritik nuqtalarini topamiz:

$$\begin{cases} \frac{\partial z}{\partial x} = \cos x - \cos(x + y) = 0, \\ \frac{\partial z}{\partial y} = \cos y - \cos(x + y) = 0. \end{cases}$$

Bundan $x = \frac{2\pi}{3}$, $y = \frac{2\pi}{3}$.

Demak, $P_0\left(\frac{2\pi}{3}; \frac{2\pi}{3}\right)$, $z(P_0) = \frac{3\sqrt{3}}{2}$.

2°. Funksiyaning soha chegarasidagi eng katta va eng kichik qiymatlarini topamiz:

D sohaning chegarasida, ya'ni $x = 0$, $y = 0$ va $x + y - 2\pi = 0$ to'g'ri

chiziqlarda yotuvchi barcha $P(x; y)$ nuqtalarda berilgan funksiya nolga teng.

3°. Funksiyaning hisoblangan qiymatlarini solishtiramiz.

Demak,

$$z_{eng\ katta} = z(P_0) = \frac{3\sqrt{3}}{2} \quad \text{va} \quad z_{eng\ kichik} = z(P) = 0. \quad \text{☞}$$

3-misol. $z = x^2 - y^2$ funksiyaning $x^2 + y^2 \leq 4$ doiradagi eng katta va eng kichik qiymatlarini toping.

☞ 1°. Funksiyaning xususiy hosilalarini nolga tenglaymiz:

$$\begin{cases} \frac{\partial z}{\partial x} = 2x = 0, \\ \frac{\partial z}{\partial y} = -2y = 0. \end{cases}$$

Bundan $x = 0, y = 0$. Demak, $O(0; 0)$, $z(O) = 0$.

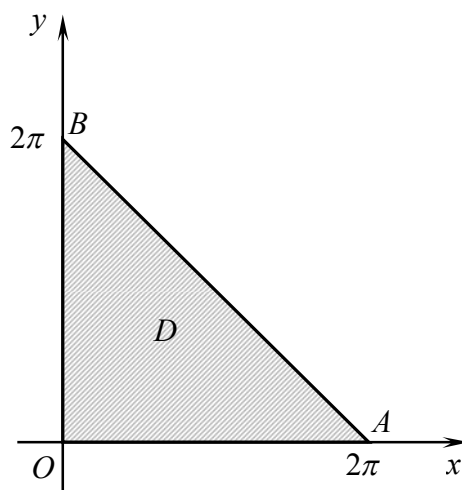

3-shakl.

2°. Funksiyaning $x^2 + y^2 = 4$ aylanadagi eng katta va eng kichik qiymatlarini hisoblaymiz. Buning uchun aylana tenglamasidan topilgan $y^2 = 4 - x^2$ ni funksiyaning berilgan tenglamasiga qo'yamiz: $z = 2x^2 - 4$. Natijada bir o'zgaruvchining funksiyasi hosil bo'ladi.

$z = 2x^2 - 4$ funksiyaning $[-2;2]$ kesmadagi eng katta va eng kichik qiymatlarini hisoblaymiz:

1) $z' = 4x = 0$ dan $x_0 = 0$. U holda $z_0 = z(0) = -4$, bunda $y_{01} = -2$ va $y_{02} = 2$;

2) $z_1 = z(-2) = 2 \cdot 4 - 4 = 4$, bunda $y_1 = 0$ va $z_2 = z(2) = 2 \cdot 4 - 4 = 4$, bunda $y_2 = 0$;

3) Demak, $x^2 + y^2 = 4$ aylananing $P_0(0;-2)$ va $P_1(0;2)$ nuqtalarida $z = -4$, $P_2(-2;0)$ va $P_3(2;0)$ nuqtalarida $z = 4$.

3°. Funksiyaning hisoblangan qiymatlarini solishtiramiz.

Demak,

$$z_{eng\ katta} = z(-2,0) = z(2,0) = 4, \quad z_{eng\ kichik} = z(0,-2) = z(0,2) = -4. \quad \odot$$

4-misol. $z = x^2 + 2xy - 3y^2 + y$ funksiyaning $x = 0$, $y = 0$ va $x + y - 1 = 0$ to'g'ri chiziqlar bilan chegaralangan D sohadagi eng katta va eng kichik qiymatlarini toping.

\odot D soha OAB uchburchakdan iborat (4-shakl).

1°. Funksiyaning kritik nuqtalarida xususiy hosilalar nolga teng bo'ladi:

$$\begin{cases} \frac{\partial z}{\partial x} = 2(x + y) = 0, \\ \frac{\partial z}{\partial y} = 2x - 6y + 1 = 0 \end{cases}$$

Bundan $x = -\frac{1}{8}, y = \frac{1}{8}$. Bu nuqta D sohada yotmaydi. Demak, D sohada berilgan funksiyaning ekstremum nuqtalari yo'q.

2°. Funksiyani soha chegarasida ekstremumga tekshiramiz. Soha chegarasi turli tenglamalar bilan aniqlanuvchi uchta qismdan tashkil topgani sababli funksiyaning har bir qismda ekstremumga alohida tekshiramiz.

1) OA to'g'ri chiziqda $y = 0$ va $z = x^2$ ($0 \leq x \leq 1$). $z = x^2$ funksiya $x \geq 0$ da o'suvchi bo'lgani uchun, uning $[0;1]$ kesmadagi eng katta qiymati $z(1,0) = 1$ va eng kichik qiymati $z(0,0) = 0$ bo'ladi.

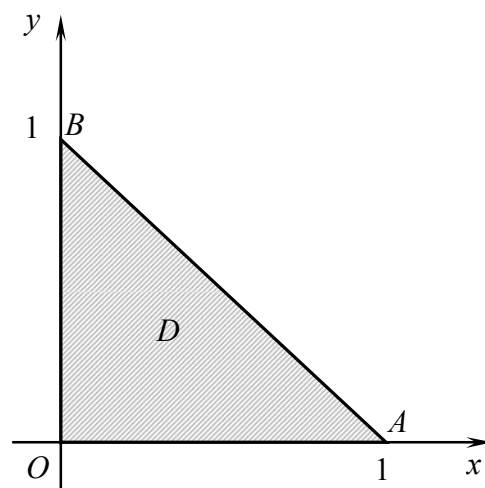

4-shakl.

2) AB to'g'ri chiziqda $y = 1 - x$ ($0 \leq x \leq 1$) va $z = -4x^2 + 7x - 2$.

U holda $z'_x = -4x + 7 = 0$. Bundan $x = \frac{7}{8}$. Demak, $y = \frac{1}{8}$ va $z\left(\frac{7}{8}, \frac{1}{8}\right) = \frac{17}{16}$. AB to'g'ri chiziqning chetki nuqtalarida: $z(0,0) = 0$, $z(0,1) = -2$.

3) BO to'g'ri chiziqda $x = 0$ va $z = -3y^2 + y$. U holda $z'_y = -6y + 1 = 0$. Bundan $y = \frac{1}{6}$ va $z\left(0, \frac{1}{6}\right) = \frac{1}{12}$. BO to'g'ri chiziqning chetki nuqtalarida: $z(0,1) = -2$, $z(0,0) = 0$.

3°. Funksiyaning hisoblangan qiymatlarini taqqoslaymiz.

Demak,

$$z_{eng\ katta} = z\left(\frac{7}{8}, \frac{1}{8}\right) = \frac{17}{16} \text{ va } z_{eng\ kichik} = z(0,1) = -2. \quad \bullet$$

1.3.3. Funksiyaning argumentlari hech bir qo'shimcha shartlar bilan bog'lanmagan holda topilgan ekstremumlariga *shartsiz ekstremumlar* deyiladi.

Funksiyaning argumentlari hech bir qo'shimcha shartlar bilan bog'langan holda topilgan ekstremumlariga *shartli ekstremumlar* deyiladi.

$\varphi(x, y) = 0$ tenglama berilgan bo'lib, $P_0(x_0; y_0)$ nuqta bu tenglamani qanoatlantirsin hamda $z = f(x, y)$ funksiya $P_0(x_0; y_0)$ nuqtaning biror δ - atrofida aniqlangan va bu nuqtada uzluksiz bo'lsin.

☑ Agar δ - atrofning $\varphi(x, y) = 0$ tenglamani qanoatlantiruvchi barcha $P(x; y)$ nuqtalarida $f(x, y) < f(x_0, y_0)$ ($f(x, y) > f(x_0, y_0)$) tengsizlik bajarilsa, $P_0(x_0; y_0)$ nuqtaga $f(x, y)$ funksiyaning *shartli maksimum (shartli minimum)* nuqtasi deyiladi.

Bunda $\varphi(x, y) = 0$ tenglama *bog'lanish tenglamasi* deb ataladi, ekstremumga bog'lanish tenglamasi bilan bog'langanlik shartida erishiladigan ekstremum deyiladi.

⇒ Ikki o'zgaruvchining funksiyasi uchun shartli ekstremumni topish masalasi quyidagi usullardan biri bilan yechiladi:

1. Agar $\varphi(x, y) = 0$ bog'lanish tenglamasini y yoki x ga nisbatan yechish mumkin bo'lsa, bu tenglamadan $y = y(x)$ yoki $x = x(y)$ topiladi va u $z = f(x, y)$ funksiyaga qo'yiladi. Hosil bo'lgan bir o'zgaruvchining funksiyasi ekstremumga tekshiriladi;

2. Agar $\varphi(x, y) = 0$ bog'lanish tenglamasini y yoki x ga nisbatan yechish mumkin bo'lmasa, *Lagranj ko'paytuvchilari usuli* qo'llaniladi.

Ikki o'zgaruvchining funksiyasini Lagranj ko'paytuvchilari usulu bilan ekstremumga tekshirish quyidagi tartibda amalga oshiriladi:

1°. Lagranj funksiyasi deb ataluvchi

$$F(x, y) = f(x, y) + \lambda \varphi(x, y)$$

funksiya tuziladi va uning x , y va λ bo'yicha xususiy hosilalari topiladi, bu yerda λ – lagranj ko'paytuvchisi deb ataluvchi son;

2°. Shartli ekstremumning zaruruy sharti

$$\begin{cases} F'_x(x, y) = 0, \\ F'_y(x, y) = 0, \\ \varphi(x, y) = 0 \end{cases}$$

sistema bilan beriladi. Bu sistemadan bitta yoki bir nechta (x_0, y_0, λ) sonlar uchligi topiladi, bu yerda $P_0(x_0; y_0)$ shartli ekstremum bo'lishi mumkin bo'lgan nuqta;

3°. Shartli ekstremumning yetarli sharti

$$\Delta = - \begin{vmatrix} 0 & \varphi'_x(x_0, y_0) & \varphi'_y(x_0, y_0) \\ \varphi'_x(x_0, y_0) & F''_{x^2}(x_0, y_0, \lambda) & F''_{xy}(x_0, y_0, \lambda) \\ \varphi'_y(x_0, y_0) & F''_{xy}(x_0, y_0, \lambda) & F''_{y^2}(x_0, y_0, \lambda) \end{vmatrix}$$

determinant orqali ifodalanadi.

Bunda har bir (x_0, y_0, λ) sonlar uchligi uchun Δ ning ishorasi tekshiriladi:

a) agar $\Delta < 0$ bo'lsa $P_0(x_0; y_0)$ nuqta $z = f(x, y)$ funksiyaning shartli maksimum nuqtasi bo'ladi;

b) agar $\Delta > 0$ bo'lsa $P_0(x_0; y_0)$ nuqta $z = f(x, y)$ funksiyaning shartli minimum nuqtasi bo'ladi.

5-misol. $z = 4 - x^2 + 2x - y^2 + 4y$ funksiyaning x va y o'zgaruvchilar $y - x = 0$ tenglama bilan bog'langanlik shartidagi ekstremumini toping.

☞ Masalani har ikkala usul bilan yechamiz.

1-usul. Funksiya tenglamasida to'la kvadratlar ajratamiz:

$$z = 9 - (x - 1)^2 - (y - 2)^2.$$

Bu funksiya uchi $M_0(1; 2; 9)$ nuqtada yotgan paraboloidni ifodalaydi.

Bog'lanish tenglamasi $y - x = 0$ tekislikni ifodalaydi. Bu tenglamadan $y = x$ kelib chiqadi. y ni berilgan funksiyaga qo'yib, topamiz:

$$z = 4 - 2x^2 + 6x.$$

Bu funksiya parabolani ifodalaydi. Demak, $z = 4 - x^2 + 2x - y^2 + 4y$ paraboloid bilan $y - x = 0$ tekislik kesishishidan parabola hosil bo'ladi.

$z = 4 - 2x^2 + 6x$ funksiyaning ekstremumiga tekshiramiz:

$$1^\circ. z'_x = -4x + 6 = 0 \text{ dan } x = \frac{3}{2}, y = \frac{3}{2};$$

$$2^\circ. z''_{xx} = -4 < 0. \text{ Demak, } P_0\left(\frac{3}{2}; \frac{3}{2}\right) - \text{maksimum nuqta.}$$

Shunday qilib, $z = 4 - x^2 + 2x - y^2 + 4y$ funksiya uchun $P_0\left(\frac{3}{2}; \frac{3}{2}\right)$ shartli maksimum nuqta bo'ladi. Bundan

$$z_{\max} = 4 - \left(\frac{3}{2}\right)^2 + 2 \cdot \frac{3}{2} - \left(\frac{3}{2}\right)^2 + 4 \cdot \frac{3}{2} = \frac{17}{2}.$$

2-usul. 1°. Lagranj funksiyasini tuzamiz:

$$F(x, y, z) = 4 - x^2 + 2x - y^2 + 4y + \lambda(y - x), \text{ bu yerda } \varphi(x, y) = y - x.$$

Bundan

$$F'_x = -2x + 2 - \lambda, \quad F'_y = -2y + 4 + \lambda, \quad F'_\lambda = y - x.$$

2°. Shartli ekstremumning zarur shartiga ko'ra

$$\begin{cases} -2x + 2 - \lambda = 0, \\ -2y + 4 + \lambda = 0, \\ y - x = 0. \end{cases}$$

Sistemani yechamiz: $x = \frac{3}{2}, y = \frac{3}{2}, \lambda = 1$. Demak, $P_0\left(\frac{3}{2}; \frac{3}{2}\right)$ - mumkin bo'lgan shartli ekstremum nuqta.

3°. Δ determinantga qo'yiladigan xususiy hosilalarni topamiz:

$$\varphi'_x = -1, \quad \varphi'_y = 1, \quad F''_{x^2} = -2, \quad F''_{xy} = 0, \quad F''_{y^2} = -2.$$

U holda

$$\Delta = - \begin{vmatrix} 0 & -1 & 1 \\ -1 & -2 & 0 \\ 1 & 0 & -2 \end{vmatrix} = -4.$$

Barcha nuqtalarda, jumladan $P_0\left(\frac{3}{2}; \frac{3}{2}\right)$ nuqtada $\Delta_1 = -4 < 0$.

Demak, bu nuqtada funksiya shartli maksimumga ega:

$$z_{\max} = 4 - \left(\frac{3}{2}\right)^2 + 2 \cdot \frac{3}{2} - \left(\frac{3}{2}\right)^2 + 4 \cdot \frac{3}{2} = \frac{17}{2}. \quad \odot$$

⇒ 1.3.4. Bir necha o‘zgaruvchi funksiyasini ekstremumga tekshirishning amaliy tatbiqlaridan biri eng kichik kvadratlar usuli hisoblanadi. Bu usulning mohiyati $y = f(x)$ empirik formula bilan topilgan $f(x_i)$ nazariy qiymatlarning tajriba natijasida olingan mos y_i qiymatlardan chetlashishi kvadratlarining yig‘indisini minimallashtirishdan yoki boshqacha aytganda

$$S = \sum_{i=1}^n \delta_i^2 = \sum_{i=1}^n (f(x_i) - y_i)^2$$

qiymatning minimal bo‘lishini ta’minlashdan iborat.

Agar empirik formula sifatida $y = ax + b$ chiziqli funksiya olinsa, a va b koeffitsiyentlar

$$\begin{cases} a \cdot \sum_{i=1}^n x_i^2 + b \cdot \sum_{i=1}^n x_i = \sum_{i=1}^n x_i y_i, \\ a \cdot \sum_{i=1}^n x_i + b \cdot n = \sum_{i=1}^n y_i \end{cases}$$

tenglamalar sistemasidan topiladi.

Agar empirik formula sifatida $y = ax^2 + bx + c$ parabolik funksiya olinsa, a, b va c koeffitsiyentlar

$$\begin{cases} a \cdot \sum_{i=1}^n x_i^4 + b \cdot \sum_{i=1}^n x_i^3 + c \cdot \sum_{i=1}^n x_i^2 = \sum_{i=1}^n x_i^2 y_i, \\ a \cdot \sum_{i=1}^n x_i^3 + b \cdot \sum_{i=1}^n x_i^2 + c \cdot \sum_{i=1}^n x_i = \sum_{i=1}^n x_i y_i, \\ a \cdot \sum_{i=1}^n x_i^2 + b \cdot \sum_{i=1}^n x_i + c \cdot n = \sum_{i=1}^n y_i \end{cases}$$

sistemadan topiladi.

Agar empirik formula sifatida logarifmik funksiya olinsa, bu funksiya belgilashlar yordamida chizqli yoki parabolik funksiya keltiriladi.

Agar empirik formula sifatida darajali yoki ko‘rsatkichli funksiya olinsa, bu funksiya avval logarifmlanadi va keyin belgilashlar yordamida chizqli yoki parabolik funksiya keltiriladi.

6-misol. x argument va $y = f(x)$ funksiyaning tajriba natijasida olingan qiymatlari jadvalda berilgan:

x	110	132	154	176	198	230	242
y	40	43,2	52,8	67,2	64	78,4	96

x va y o‘zgaruvchilar orasidagi chiziqli bog‘lanishning empirik funksiyasini eng kichik kvadratlar usuli bilan toping.

⇒ Empirik formulani $y = ax + b$ ko‘rinishda izlaymiz. Bu funksiyaning

a va b parametrlarini

$$\begin{cases} a \cdot \sum_{i=1}^7 x_i^2 + b \cdot \sum_{i=1}^7 x_i = \sum_{i=1}^7 x_i y_i, \\ a \cdot \sum_{i=1}^7 x_i + b \cdot n = \sum_{i=1}^7 y_i \end{cases}$$

tenglamalar sistemasidan topamiz.

Qulaylik uchun hisoblarni jadvalda bajaramiz:

i	x_i	y_i	x_i^2	$x_i y_i$
1	110	40	12100	4400
2	132	43,2	17424	5702,4
3	154	52,8	23716	8131,2
4	176	67,2	30976	11827,2
5	198	64	39204	12672
6	220	78,4	48400	17248
7	242	96	58564	23232
Σ	1232	441,6	230384	83212,8

U holda yuqoridagi sistema

$$\begin{cases} 230384a + 1232b = 83212,8, \\ 1232a + 7b = 441,6 \end{cases}$$

ko'rinishga keladi.

Uni Kramer formulalari bilan yechamiz:

$$\Delta = \begin{vmatrix} 230384 & 1232 \\ 1232 & 7 \end{vmatrix} = 94864,$$

$$\Delta_a = \begin{vmatrix} 83212,8 & 1232 \\ 441,6 & 7 \end{vmatrix} = 38438,4, \quad \Delta_b = \begin{vmatrix} 230384 & 83212,8 \\ 1232 & 441,6 \end{vmatrix} = -780595,2.$$

$$a = \frac{38438,4}{94864} = 0,405, \quad b = -\frac{780595,2}{94864} = -8,229.$$

Demak, izlanayotgan funksiya

$$y = 0,405x - 8,229. \quad \text{☞}$$

Mustahkamlash uchun mashqlar

1.3.1. Funksiyalarni ekstremumga tekshiring.

1) $z = x^3 + y^2 - 3x + 2y;$

2) $z = x^3 + y^3 - 3xy;$

3) $z = x^4 + y^4 - 4xy;$

4) $z = x^4 + y^4 - 2x^2 + 4xy - 2y^2;$

$$5) z = 2x^3 + \frac{1}{3}y^2 + \frac{6}{x} - \frac{18}{y};$$

$$6) z = xy + \frac{50}{x} + \frac{20}{y};$$

$$7) z = y\sqrt{x} - y^2 - x + 6y;$$

$$8) z = x^3 + y^3 - 6x + 2y\sqrt{y};$$

$$9) z = xy^2(1 - x - y);$$

$$10) z = xy(x + y - 2);$$

$$11) z = e^{x-y}(x^2 - 2y^2);$$

$$12) z = e^{\frac{x}{2}}(x + y^2).$$

1.3.2. Funktsiyalarning berilgan chiziqlar bilan chegaralangan D sohadagi eng katta va eng kichik qiymatlarini toping.

$$1) z = x^2 + 2xy + 4x - y^2, \quad D: x=0, y=0, x+y+2=0;$$

$$1) z = x^2 - xy + y^2 - 4y - x, \quad D: x=0, y=0, 3x+2y-12=0;$$

$$3) z = x^3 + y^3 - 3xy, \quad D: x=0, x=2, y=-1, y=2;$$

$$4) z = x^3y + x^2y^2 - 4x^2y, \quad D: x=0, y=0, x+y=6;$$

$$5) z = xy(x+y+1), \quad D: y=\frac{1}{x}, x=1, x=2, y=-\frac{3}{2};$$

$$6) z = x + 2y - 3, \quad D: x^2 + y^2 = 4.$$

1.3.3. $z = f(x, y)$ funksiylarning $\varphi(x, y) = 0$ tenglama bilan bog'langanlik shartidagi ekstremumlarini toping.

$$1) z = x + 3y, \quad x^2 + y^2 - 10 = 0;$$

$$2) z = x + y, \quad 2y^2 + 2x^2 - x^2y^2 = 0;$$

$$3) z = xy, \quad x^2 + y^2 - 2 = 0;$$

$$4) z = xy, \quad x + y - 1 = 0;$$

$$5) z = xy^2, \quad x + 2y - 1 = 0;$$

$$6) z = x^2y, \quad x^2 + y^2 - 1 = 0;$$

$$7) z = x^2 + y^2, \quad x + y - 1 = 0;$$

$$8) z = 3x^2 - 2y^2, \quad x^2 + y^2 - 1 = 0;$$

$$9) z = \frac{1}{x} + \frac{1}{y}, \quad x + y - 2 = 0;$$

$$10) z = \frac{1}{x^2} - \frac{1}{8y^2}, \quad x - y - 2 = 0;$$

$$11) z = \sqrt{1 - x^2 - y^2}, \quad x + y - 1 = 0;$$

$$12) z = e^{xy}, \quad x + y - 2 = 0.$$

1.3.4. Sig'imi V ga teng bo'lgan to'g'ri burchakli hovuz eng kichik to'la sirtga ega bo'lsa, uning o'lchamlarini toping.

1.3.5. R radiusli sharga ichki chizilgan to'g'ri burchakli parallelepiped eng katta hajmga ega bo'lsa, uning o'lchamlarini toping.

1.3.6. x argument va $y = f(x)$ funksiyaning tajriba natijasida olingan qiymatlari jadvalda berilgan:

1)	x	-1	0	1	2	3	4
	y	0	2	3	3,5	3	4,5

2)	x	0,5	1,0	2,0	2,5	3	3,5
	y	0,62	1,64	3,7	5,02	6,04	6,78

x va y o'zgaruvchilar orasidagi chiziqli bog'lanishning empirik funksiyasini eng kichik kvadratlar usuli bilan toping.

NAZORAT ISHI

1. Funksiyaning aniqlanish sohasini toping va chizmada tasvirlang.

2. Funksiyaning $P_0(x_0; y_0)$ nuqtadagi qiymatini taqribiy hisoblang

1-variant

1. $z = \sqrt{4x - x^2 - y^2}$.

2. $z = \sqrt[3]{2x^2 - 3xy}$, $P_0(3,94; 2,01)$.

2-variant

1. $z = \ln(16 - x^2 - y^2) + \sqrt{\ln x}$.

2. $z = 2y + \operatorname{arctg}(xy)$, $P_0(0,01; 2,95)$.

3-variant

1. $z = \arccos \frac{2x}{\sqrt{x^2 + y^2}}$.

2. $z = \ln(x^3 + y^2)$, $P_0(0,09; 0,99)$.

4-variant

1. $z = \frac{\sqrt{xy}}{x^2 + y^2}$.

2. $z = x^2 + y^2 + 2 \sin(xy)$, $P_0(0,04; 2,97)$.

5-variant

1. $z = \sqrt{\ln(8 - x^2 - y^2)}$.

2. $z = 2y + \sin \frac{x}{y}$, $P_0(0,05; 4,98)$.

6-variant

1. $z = \arcsin(3x - y)$.

2. $z = \operatorname{arctg} \left(\frac{x}{y} - 1 \right)$, $P_0(2,02; 0,97)$.

7-variant

1. $z = \sqrt{y - \sqrt{x}}$.

2. $z = y^x$, $P_0(3,03; 0,98)$.

8-variant

1. $z = \sqrt{1 - x^2} + \sqrt{y^2 - 1}$.

2. $z = \sqrt{x^4 + y^3}$, $P_0(1,02; 1,98)$.

9-variant

1. $z = \frac{\sqrt{3x-4y}}{x^2+y^2+2}$.

2. $z = \sqrt[3]{x^3 - \ln y}$, $P_0(2,98;1,04)$.

10-variant

1. $z = \arcsin \frac{x}{y+1}$.

2. $z = 2x + \sin \frac{x-2}{y}$, $P_0(1,98;3,96)$.

11-variant

1. $z = \sqrt{8x - x^2 + y^2}$.

2. $z = 3y + \operatorname{tg} \frac{x-1}{y}$, $P_0(0,96;1,98)$.

12-variant

1. $z = 3 + \sqrt{-x^2 - y^2 + 2xy}$.

2. $z = 2y^2 + \arcsin \frac{x}{y}$, $P_0(0,02;3,98)$.

13-variant

1. $z = \ln \left(1 - \frac{x^2}{4} - \frac{y^2}{9} \right)$.

2. $z = \ln(\sqrt[4]{x} + \sqrt[3]{y} - 1)$, $P_0(0,97;1,04)$.

14-variant

1. $z = \sqrt{\frac{x^2 + y^2 + 2xy}{x^2 + y^2 - 2xy}}$.

2. $z = \sqrt{2x^2 + 2xy - 3y^2}$, $P_0(2,02;0,96)$.

15-variant

1. $z = \frac{\ln 3x}{\sqrt{x^2 + y^2 - 9}}$.

2. $z = \sqrt{x^3 + y^3}$, $P_0(1,02;1,97)$.

16-variant

1. $z = \frac{\sqrt{x^2 - y^2}}{xy}$.

2. $z = 2x^2 + 5y + \cos(xy)$, $P_0(1,99;0,02)$.

17-variant

1. $z = \sqrt{25 - x^2 - y^2} + \sqrt{xy}$.

2. $z = y - \arcsin(xy)$, $P_0(0,02;3,98)$.

18-variant

1. $z = \ln(x^2 + y^2 - 6) + \sqrt{\ln y}$.

2. $z = \sqrt[3]{x^3 + y^3}$, $P_0(3,96;0,02)$.

19-variant

1. $z = \arcsin \frac{x}{y}$.

2. $z = e^{xy} + 2 \cos(xy)$, $P_0(1,98;0,03)$.

$$1. z = \frac{\ln(y-1)}{\sqrt{y-x^2+4}}.$$

$$1. z = \sqrt{(x^2+y^2-1)(4-x^2-y^2)}.$$

$$1. z = \ln(x^2-2y+4) + \sqrt{x}.$$

$$1. z = \frac{1}{\sqrt{x+y}} + \sqrt{x-y}.$$

$$1. z = \arccos \frac{y}{x+y}.$$

$$1. z = \frac{\ln y}{\sqrt{3-y^2-x^2}}.$$

$$1. z = \frac{1}{\sqrt{x^2+y^2-6}} + \frac{1}{\sqrt{x}}.$$

$$1. z = \frac{\sqrt{x^2-2y+4}}{4x}.$$

$$1. z = \frac{\ln x}{\sqrt{-y^2-x^2+5}}.$$

$$1. z = \frac{e^{\sqrt{x^2+y^2-1}}}{\sqrt{x+y}}.$$

$$1. z = \frac{\arcsin(x-y)}{\sqrt{x^2-y-1}}.$$

20-variant

$$2. z = \ln(2x^2+2y^2), \quad P_0(0,54;0,48).$$

21-variant

$$2. z = x^y, \quad P_0(1,08;3,96).$$

22-variant

$$2. z = x^2 + \arcsin(xy^2), \quad P_0(3,97;0,03).$$

23-variant

$$2. z = \sqrt[3]{2x^2+6y}, \quad P_0(0,97;0,98).$$

24-variant

$$2. z = \sqrt{5e^x+y^2}, \quad P_0(0,02;2,04).$$

25-variant

$$2. z = x^2 + 2y \sin(xy), \quad P_0(0,05;1,96).$$

26-variant

$$2. z = e^y \ln(x+2y), \quad P_0(0,98;0,03).$$

27-variant

$$2. z = \sqrt{e^{4x^2-y^2}}, \quad P_0(0,98;2,03).$$

28-variant

$$2. z = \ln(3x^2-2xy), \quad P_0(1,03;0,98).$$

29-variant

$$2. z = e^{xy} \operatorname{arctg}(xy), \quad P_0(2,05;0,03).$$

30-variant

$$2. z = \sqrt{x^3+xy+y^2}, \quad P_0(2,06;1,96).$$

1-MUSTAQIL ISH

1. Sirtga $M_0(x_0; y_0; z_0)$ nuqtada o'tkazilgan urinma tekislik va normal tenglamalarini tuzing.
2. $z = f(x, y)$ funksiya berilgan tenglikni qanoatlantirishini ko'rsating.
3. Murakkab funksiyaning ko'rsatilgan hosilalarini toping.
4. Oshkormas ko'rinishda berilgan $z = z(x, y)$ funksiyaning birinchi tartibli xususiy hosilalarini toping.
5. Funksiyaning uchinchi tartibli differensialini toping.
6. Funksiyani ekstremumga tekshiring.
7. $z = f(x, y)$ funksiyaning D yopiq sohadagi eng katta va eng kichik qiymatlarini toping.
8. $z = f(x, y)$ funksiyaning $\varphi(x, y) = 0$ tenglama bilan bog'langanlik shartidagi ekstremumlarini toping.
9. Eng katta va eng kichik qiymatlarni topishga oid amaliy masalalarni yeching.
10. x argument va $y = f(x)$ funksiyaning tajriba natijasida olingan qiymatlari jadvalda berilgan. x va y o'zgaruvchilar orasidagi $y = ax^2 + bx + c$ empirik funksiyaning eng kichik kvadratlar usuli bilan toping. Tajriba nuqtalarini va empirik funksiyaning to'g'ri burchakli dekart koordinatalar sistemasida tasvirlovchi chizmani chizig.

1-variant

1. $z = 2x^2 - 3y^2 + 4x - 2y - 10xy$, $M_0(-1; 1; 3)$.
2. $z = \ln(x^2 + xy + y^2)$, $(z'_x)^2 - (z'_y)^2 + z''_{xx} - z''_{yy} = 0$.
3. $z = \ln(x^3 + 3y)$, $x = utgv$, $y = \frac{v}{u^3}$, $\frac{\partial z}{\partial u}$, $\frac{\partial z}{\partial v} - ?$
4. $x^3 + 2y^3 + z^3 - 3xyz = 2y$.
5. $z = x^3 \cos y + y^3 \sin x$.
6. $z = x^3 + y^3 - 18xy + 7$.
7. $z = 5x^2 - 3xy + y^2 + 4$, $D: x = -1, y = -1, x + y - 1 = 0$.
8. $z = 8 - 5x - 4y$, $x^2 - y^2 - 9 = 0$.
9. Perimetri $2p$ ga teng uchburchak eng katta yuzaga ega bo'lsa, uchburchakning tomonlarini toping.

10.

x_i	0	1	2	3	4	5
y_i	-0,8	0,4	0,3	-0,5	-2,0	-4,9

2-variant

1. $x^2 + y^2 - z^2 + 2x - 2xy - z = 0$, $M_0(1;1;-2)$.

2. $z = x^{y^2}$, $yz \cdot z''_{yy} - z \cdot z'_y - y \cdot (z'_y)^2 = 0$.

3. $u = \frac{yz}{x}$, $x = e^t$, $y = \ln t$, $z = t^2 - 1$, $\frac{du}{dt} = ?$

4. $xy^2 + yz^2 + zx^2 = 2xyz$.

5. $z = \cos(3x + e^{-y})$.

6. $z = \ln(x + y) - 2x^4 - 2y^4$.

7. $z = (x - y)(4 - x - y)$, $D: x = 0, x + 2y - 4 = 0, x - 2y - 4 = 0$.

8. $z = xy$, $x^2 + y^2 - 1 = 0$.

9. Devorining qalinligi d ga va hajmi V ga teng ochiq quti (yashik) yasash uchun eng kam material sarflangan bo'lsa, qutining tashqi o'lchamlarini toping.

10.

x_i	0	1	2	3	4	5
y_i	-0,3	-2,4	-2,8	-1,8	-0,3	2,6

3-variant

1. $2x^2 - 3y^2 + xy + 3x - z - y = 0$, $M_0(1;-1;2)$.

2. $z = xsh(x + y) + ych(x + y)$, $z''_{xx} - 2z''_{xy} + z''_{yy} = 0$.

3. $z = \arctg \frac{x+1}{y}$, $y = e^{(x+1)^2}$, $\frac{dz}{dx} = ?$

4. $z = x + \arctg \frac{y}{z-x}$.

5. $z = e^{x+y} sh(x - y)$.

6. $z = xy + \frac{1}{x} + \frac{8}{y}$.

7. $z = x^2 + 2xy - y^2 - 2x + 2y$, $D: x = 0, y = 0, x - y + 2 = 0$.

8. $z = \frac{1}{\sqrt{x}} + \frac{2}{\sqrt{y}}$, $x + 2y - 3 = 0$.

9. Tagi silindr ko'rinishiga va tepasi konus shakliga ega chodirni tikish uchun eng kam material sarflangan bo'lsa, chodirning o'lchamlari nisbatini toping.

10.

x_i	0	1	2	3	4	5
y_i	-0,5	-1,5	-1,8	-0,8	1,6	4,5

4-variant

1. $x^2 + y^2 + z^2 - 4x + 6z + 8 = 0$, $M_0(2;1;-1)$.

2. $z = \ln(x + e^{-y})$, $z'_x \cdot z''_{xy} - z'_y \cdot z''_{xx} = 0$.

3. $z = x^y + y^x$, $x = u^2 + v^2$, $y = v^2 - u^2$, $\frac{\partial z}{\partial u}$, $\frac{\partial z}{\partial v} - ?$

4. $\frac{x}{z} = \ln \frac{x}{y} + yz^2$.

5. $z = \ln \cos(xy)$.

6. $z = x\sqrt{y} - x^2 - yx + 6x + 3$.

7. $z = xy(5 - 3x - 15y)$, $D: x = 0, y = 0, 4x + y - 8 = 0$.

8. $z = \frac{1}{\sqrt[3]{x}} + \frac{4}{\sqrt[3]{y}}$, $x + 4y - 5 = 0$.

9. Radiusi R ga teng aylanaga ichki chizilgan uchburchak eng katta yuzaga ega bo'lsa, uning tomonlarini toping.

10.

x_i	0	1	2	3	4	5
y_i	-0,3	0,6	1,3	2,0	1,7	1,2

5-variant

1. $y^2 + z^2 - 4x^2 + 2xy + 3xz - 6 = 0$, $M_0(1;-2;2)$.

2. $z = \frac{xy}{x - y}$, $z''_{xx} + 2z''_{xy} + z''_{yy} - \frac{2}{xy} \cdot z = 0$.

3. $z = \frac{x}{y} + \frac{y}{x}$, $x = u \sin v$, $y = v \cos u$, $\frac{\partial z}{\partial u}$, $\frac{\partial z}{\partial v} - ?$

4. $x^2 - y^2 - z^2 = \cos z$.

5. $z = \frac{x}{y} + \frac{y}{x}$.

6. $z = \ln(x^2 y) - x^2 - 9y^3$.

7. $z = x^3 - 3y^2 - 3xy$, $D: x = 0, x = 2, y = 0, y = 1$.

8. $z = 9 - 5x + 3y$, $x^2 - y^2 - 16 = 0$.

9. Uchlari $x^2 + 3y^2 = 15$ ellipsning $A(\sqrt{3};-2)$, $B(-2\sqrt{3};1)$ va $C(x;y)$ nuqtalarida yotgan uchburchakning yuzasi eng katta bo'lsa, $C(x;y)$ nuqtani toping.

10.

x_i	0	1	2	3	4	5
y_i	0,4	0,2	1,2	1,7	2,2	4,0

6-variant

1. $z = x^2 - y^2 - 2xy - x - 2y$, $M_0(-1;1;1)$.

2. $z = \frac{y}{\ln(x^2 - y^2)}$, $\frac{1}{x} \cdot z'_x + \frac{1}{y} z'_y - \frac{1}{y^2} \cdot z = 0$.

3. $z = \arcsin \frac{x}{y}$, $x = \sin t$, $y = \cos t$, $\frac{dz}{dt} = ?$

4. $x^2 + y^2 = e^{xz} + 2yz$.

5. $z = \frac{xy}{x + y}$.

6. $z = x^3 + 8y^3 - 6xy + 1$.

7. $z = x^2 + 2yx - 4x + 8y$, $D: x=2, y=0, 5x - 3y + 45 = 0$.

8. $z = 2\sqrt{x} - 3\sqrt{y}$, $4x - 6y + 1 = 0$.

9. Radiusi R ga teng sharga tashqi chizilgan konus eng kichik hajmga ega bo'lsa, konusning o'lchamlarini toping.

10.

x_i	0	1	2	3	4	5
y_i	4,9	5,4	5,0	4,6	3,3	1,5

7-variant

1. $x^2 + y^2 - 3z^2 + xy + 2z = 0$, $M_0(1;0;1)$.

2. $z = xtg(x + y) + y^2 + xy$, $z''_{xx} - 2z''_{xy} + z''_{yy} = 0$.

3. $z = \frac{x^2 + xy}{1 + y}$, $y = x \cos x$, $\frac{dz}{dx} = ?$

4. $yz = x + y^2 tg \frac{x}{z}$.

5. $z = e^{4y} \ln(xy)$.

6. $z = y\sqrt{x} - y^2 - x + 6y$.

7. $z = xy(2 - 2x - y)$, $D: x=0, x=1, y=0, y=2$.

8. $z = 5 - \frac{1}{x} + \frac{1}{y^2}$, $x^2 - 4y - 5 = 0$.

9. Yon sirti S ga teng konus eng katta hajmga ega bo'lsa, uning o'lchamlarini toping.

10.

x_i	0	1	2	3	4	5
y_i	-0,5	-1,1	-0,3	0,4	2,0	4,8

8-variant

1. $z = 2x^2 + y^2 + 4xy - 5x - 10$, $M_0(1; -7; 8)$.

2. $z = y\sqrt{\frac{y}{x}}$, $x^2 \cdot z''_{xx} - y^2 \cdot z''_{yy} = 0$.

3. $z = \sqrt{x-y} + \ln(x^2 + y)$, $x = ve^u$, $y = ue^v$, $\frac{\partial z}{\partial u}$, $\frac{\partial z}{\partial v} - ?$

4. $yx = z \ln \frac{zx}{y}$.

5. $z = e^{x-y} \operatorname{ch}(x+y)$.

6. $z = 2xy + \frac{4}{x} + \frac{1}{y}$.

7. $z = 4x^2 + 9y^2 - 4x - 6y + 3$, $D: x=0, y=0, x+y-1=0$.

8. $z = 1 + \frac{2}{x} + \frac{3}{y}$, $\frac{4}{x^2} + \frac{6}{y^2} - \frac{1}{10} = 0$.

9. $x + 3y - z = 0$ tekislikning $x^2 + y^2 = 10$ silindr bilan kesishish nuqtalari applikatalarining eng katta va eng kichik qiymatlarini toping.

10.

x_i	0	1	2	3	4	5
y_i	1,0	1,5	1,1	0,2	-0,9	-2,9

9-variant

1. $x^2 + y^2 + z^2 - 6x + 4z - 4xz = 0$, $M_0(1; 2; -1)$.

2. $z = \sqrt{x^2 + y^2}$, $z'_y \cdot z'_x + z \cdot z''_{xy} = 0$.

3. $z = \frac{\arcsin x}{y^2}$, $x = \frac{1}{5}u^5 + \frac{1}{7}v^7$, $y = \ln(uv)$, $\frac{\partial z}{\partial u}$, $\frac{\partial z}{\partial v} - ?$

4. $x^2y - zy^2 = xe^{yz}$.

5. $z = \ln(x^y y^x)$.

6. $z = 3x^2y + y^3 - 18x - 30y$.

7. $z = 4 - 2x^2 - y^2$, $D: y=0, y = \sqrt{1-x^2}$.

8. $z = 8 - 5x - 3y$, $x^2 - y^2 - 16 = 0$.

9. $4x^2 + 36y^2 = 9$ ellipsning $4x + 9y - 25 = 0$ to'g'ri chiziqdan eng uzoq va eng yaqin joylashgan nuqtalarini toping.

10.

x_i	0	1	2	3	4	5
y_i	-0,2	-0,4	0,7	0,7	2,6	4,5

10-variant

1. $x^2 + y^2 + z^2 + 6x + 4y - 8 = 0$, $M_0(1; -1; 2)$.

2. $z = \frac{x}{x^2 + y^2}$, $z''_{xx} + z''_{yy} = 0$.

3. $z = \frac{e^{xy}}{\sqrt{x+y}}$, $x = u \cos v$, $y = v \sin u$, $\frac{\partial z}{\partial u}$, $\frac{\partial z}{\partial v} - ?$

4. $x \ln y + y \ln z + z \ln x = 4$.

5. $z = (x^2 + y^2) \cdot e^{x+y}$.

6. $z = 5x + y^3 - 3 \ln(x^5 y)$.

7. $z = x^2 + 4xy - 2y^2 - 6x - 1$, $D: x=0, y=0, x+y-3=0$.

8. $z = 3\sqrt{x} + 4\sqrt{y}$, $3x + 4y - 28 = 0$.

9. Sirti S ga teng silindr shaklidagi usti ochiq idish eng ko'p sig'imga ega bo'lsa, uning o'lchamlarini toping.

10.

x_i	0	1	2	3	4	5
y_i	1,4	1,8	1,7	0,8	-1,0	-3,0

11-variant

1. $y^2 - 2x^2 - z^2 - y + 4z + 13 = 0$, $M_0(2; 1; -1)$.

2. $z = e^x(x \cos y - y \sin y)$, $z''_{xx} + z''_{yy} = 0$.

3. $z = \frac{\operatorname{tg} 2x}{y^2}$, $x = \operatorname{arctg} \sqrt{uv}$, $y = \frac{u}{v}$, $\frac{\partial z}{\partial u}$, $\frac{\partial z}{\partial v} - ?$

4. $zx = ye^{\frac{x}{z}}$.

5. $z = \ln \sin(xy)$.

6. $z = xy + \frac{2}{x^2} + \frac{1}{2y}$.

7. $z = x^2 y(4 - x - y)$, $D: x=0, y=0, x+y-6=0$.

8. $z = 4 - \frac{3}{x} + \frac{1}{2y^2}$, $3x + y - 2 = 0$.

9. Perimetri $2p$ ga teng uchburchakni biror tomoni atrofida aylantirishdan hosil bo'lgan jism eng katta hajmga ega bo'lsa, uchburchakning tomonlarini toping.

10.

x_i	0	1	2	3	4	5
y_i	-0,1	-1,3	-1,2	-0,2	1,4	3,9

12-variant

1. $z = x^2 + y^2 - 4xy + 3y - 15, M_0(3; -1; 4).$

2. $z = \frac{x}{\cos(y^2 - x^2)}, \quad \frac{1}{x} \cdot z'_x + \frac{1}{y} z'_y - \frac{1}{x^2} \cdot z = 0.$

3. $z = e^x \ln(x^2 + y^2), y = \frac{1}{2}x^2 + x, \quad \frac{dz}{dx} - ?$

4. $\cos(xy + z) - \frac{xz}{y} = 0.$

5. $z = x^2 \cos y + y^3 \sin x.$

6. $z = 2x^3 + 2y^3 + x^2y + y^2x - 9x - 9y.$

7. $z = 4x^2 + y^2 + 4x + 2y + 6, D: x = 0, y = 0, x + y + 2 = 0.$

8. $z = 5 + \frac{2}{x} + \frac{1}{y^2}, x^2 + 2y - 3 = 0.$

9. Tekis metaldan (listdan) kesib olingan umumiy yuzasi S ga teng doira va to'g'ri to'rtburchakdan silindr yasashda (bunda doiradan silindrning asosi va to'g'ri to'rtburchakdan silindrning yon sirti yasaladi) eng kam payvand chokidan foydalanilgan bo'lsa, silindrning o'lchamlarini toping.

10.

x_i	0	1	2	3	4	5
y_i	1,0	1,6	1,5	0,4	-1,3	-3,7

13-variant

1. $x^2 + y^2 + 2xz - z^2 + x - 2z - 2 = 0, M_0(1; 1; 1).$

2. $z = e^{xy} + e^{\frac{x}{y}}, \quad x^2 \cdot z''_{xx} - y^2 z''_{yy} + x \cdot z'_x - y \cdot z'_y = 0.$

3. $z = \frac{x}{y^2} + 2y, x = u\sqrt{v}, y = v \cos u, \quad \frac{\partial z}{\partial u}, \frac{\partial z}{\partial v} - ?$

4. $x + y^2 - z^3 = e^{-(x+y+z)}.$

5. $z = (x - y) \sin(x + y).$

6. $z = 4x + 3y - 2 \ln(x^4 y^3).$

7. $z = x^3 + 8y^3 - 6xy + 1, D: x = 0, x = 2, y = -1, y = 1.$

8. $z = x^2 y, 2x + y - 1 = 0.$

9. $\frac{x^2}{4} + \frac{y^2}{9} + \frac{z^2}{25} = 1$ ellipsoidga ichki chizilgan to'g'ri burchakli

parallelepiped eng katta hajmga ega bo'lsa, uning o'lchamlarini toping.

10.

x_i	0	1	2	3	4	5
y_i	-0,2	-1,2	-1,5	-1,4	0,3	2,0

14-variant

1. $x^2 + y^2 - z^2 + 6xy - z - 6 = 0$, $M_0(1;1;-2)$.

2. $z = x \sin(x + y) + y \cos(x + y)$, $z''_{xx} - 2z''_{xy} + z''_{yy} = 0$.

3. $z = \arcsin \frac{x}{y}$, $y = \sqrt{x^2 + 1}$, $\frac{dz}{dx} = ?$

4. $xe^{xyz} + yx + zy = 6$.

5. $z = e^{x+y} \cos(x - y)$.

6. $z = xy + \frac{2}{x} + \frac{4}{y^2}$.

7. $z = 3x^2 + 3y^2 - 2x - 2y + 2$, $D: x = 0, y = 0, x + y - 1 = 0$.

8. $z = 6 - 4x - 3y$, $x^2 + y^2 - 25 = 0$.

9. Diametri d ga teng sharga ichki chizilgan silindr eng kichik to'la sirtga ega bo'lsa, silindrning o'lchamlarini toping.

10.

x_i	0	1	2	3	4	5
y_i	-1,6	-0,2	0,1	-0,7	-2,5	-5,5

15-variant

1. $4x^2 - z^2 + 4xy - yz + 3z - 9 = 0$, $M_0(-2;1;1)$.

2. $z = \arctg \frac{x}{y}$, $z''_{xx} + z''_{yy} = 0$.

3. $z = y^2 \operatorname{tg} x$, $x = e^t \sin t$, $y = e^t \cos t$, $\frac{dz}{dt} = ?$

4. $5z - \ln(x^2 + y^2) = 2yz$.

5. $z = \sin(e^x + 2y)$.

6. $z = 6xy - x^2y - y^2x$.

7. $z = 2x^3 - xy^2 + y^2$, $D: x = 0, x = 1, y = 0, y = 6$.

8. $z = \frac{3}{\sqrt{x}} - \frac{1}{\sqrt{y}}$, $3x - y - 8 = 0$.

9. Asosi a ga va balandligi H ga teng muntazam to'ptburchakli piramida shaklidagi suv bilan to'ldirilgan idishga kub (piramida va kub asoslarining markazlari bu asoslarga perpendikular to'g'ri chiziqda yotadi) tashlangan. Kubning idish ichidagi qismi idishdan eng ko'p hajmdagi suv siqib chiqargan bo'lsa, kubning qirrasini toping.

10.

x_i	0	1	2	3	4	5
y_i	-1,5	-2,8	-2,6	-1,6	0,4	3,1

16-variant

1. $z = y^2 - x^2 + 2xy - 3y + 5x - 4$, $M_0(1; -1; 2)$.

2. $z = xe^{xy}$, $x^2 \cdot z''_{xx} - 2xy \cdot z''_{xy} + y^2 \cdot z''_{yy} = 0$.

3. $z = \frac{e^x + e^y}{x^2}$, $y = x \ln x$, $\frac{dz}{dx} = ?$

4. $y^2 x^3 + yz^3 + x^2 = xyz$.

5. $z = e^{3x} \ln(xy)$.

6. $z = 2x^2 + 3y^2 - 8 \ln(x^2 y^3)$.

7. $z = x^2 + y^2$, $D: x^2 + (y-1)^2 = 4$.

8. $z = 4 + \frac{2}{x} - \frac{3}{y}$, $\frac{1}{x^2} - \frac{3}{2y^2} + \frac{1}{2} = 0$.

9. Radiusi R ga va balandligi H teng konusga ichki chizilgan to'g'ri burchakli parallelopiped eng katta hajmga ega bo'lsa, parallelopipedning o'lchamlarini toping.

10.

x_i	0	1	2	3	4	5
y_i	1,3	1,9	1,8	0,7	-1,0	-3,4

17-variant

1. $x^2 + y^2 + xz - yz - 3xy - 2 = 0$, $M_0(4; 1; -1)$.

2. $z = \cos(xy) + \cos \frac{x}{y}$, $x^2 \cdot z''_{xx} - y^2 z''_{yy} + x \cdot z'_x - y \cdot z'_y = 0$.

3. $u = xz^3 + x^2 y^2 + y^3 z$, $x = t^{-2}$, $y = t^3$, $z = t^{-4}$, $\frac{du}{dt} = ?$

4. $2y^2 x^3 + yz^3 + x^2 z = 3$.

5. $z = \cos(x+y) \sin(x-y)$.

6. $z = xy^2 + \frac{1}{x} + \frac{8}{y}$.

7. $z = x^2 y(5 - 2x - 3y)$, $D: x = 0$, $y = 0$, $x + y + 2 = 0$.

8. $z = x^2 - 4y^2 + 12$, $x + y + 3 = 0$.

9. Radiusi R ga teng shardan tayyorlangan materialdan eng katta hajmga ega silindr yasalgan bo'lsa, silindrning o'lchamlarini toping.

10.

x_i	0	1	2	3	4	5
y_i	-0,5	-1,5	-1,8	-1,7	0,1	1,7

18-variant

1. $2x^2 + 2y^2 + z^2 + 8xz - z + 6 = 0, \quad M_0(-2;1;1).$

2. $z = y^{\frac{y}{x}} \sin \frac{y}{x}, \quad x^2 \cdot z'_x + xy \cdot z'_y - y \cdot z = 0.$

3. $z = \operatorname{arctg} \frac{x+1}{y}, \quad x = e^{2t}, \quad y = \ln(2t+1), \quad \frac{dz}{dt} - ?$

4. $z^3 + xyz - xy^2 = -x^3.$

5. $z = \ln sh(xy).$

6. $z = 2x^3 + 2y^3 + 3x^2y + 3y^2x - 15x - 15y.$

7. $z = x^3 + y^3 - 6xy, \quad D: x=0, x=2, y=-1, y=2.$

8. $z = 11 + 13x + 5y, \quad x^2 - y^2 - 144 = 0.$

9. O'q kesimining perimetri $6a$ ga teng silindr eng katta hajmga ega bo'lsa, uning o'lchamlarini toping.

10.

x_i	0	1	2	3	4	5
y_i	-1,2	0,2	-0,3	-0,3	-2,1	-5,1

19-variant

1. $x^2 - xy - 8x + z^3 - yz - 8 = 0, \quad M_0(2;-3;2).$

2. $z = \arcsin(xy), \quad \sqrt{1-x^2y^2} (z''_{xx} + z''_{yy}) - (x^2 + y^2) \cdot z'_x \cdot z'_y = 0.$

3. $z = e^{\frac{x+y}{y}}, \quad y = \cos^4 x, \quad \frac{dz}{dx} - ?$

4. $\sqrt{x^2 + y^2} + yx^3 - 3z = z^3$

5. $z = \ln ch(xy).$

6. $z = y\sqrt{x} - 2y^2 - x + 14y.$

7. $z = (x+y)^2 - 2x + 2y, \quad D: x=2, y=0, y-x-2=0.$

8. $z = \frac{5}{\sqrt[3]{x}} - \frac{1}{\sqrt[3]{y}}, \quad 5x - y - 12 = 0.$

9. Radiusi R ga teng yarim sharga ichki chizilgan to'g'ri burchakli parallelopiped eng katta hajmga ega bo'lsa, parallelopipedning o'lchamlarini toping.

10.

x_i	0	1	2	3	4	5
y_i	-1,3	-2,6	-2,4	-1,4	0,6	3,3

20-variant

1. $z = x^2 + y^2 - 2xy - x + 2y - 4$, $M_0(-1;1;3)$.

2. $z = y \ln(x^2 - y^2)$, $y^2 \cdot z'_x + xy \cdot z'_y - x \cdot z = 0$.

3. $u = xy^3 + xz^3$, $x = t^2 + 1$, $y = t^3$, $z = \sin t$, $\frac{du}{dt} - ?$

4. $z^3 + 2x^2 + 3y = xyz$.

5. $z = (x + y) \cos(x - y)$.

6. $z = 3xy + \frac{9}{x} + \frac{1}{y}$.

7. $z = 4x^2 - y^2 + 4xy - 8x$, $D: x=0, y=2, 2x - y = 0$.

8. $z = 4 - \frac{1}{3x^2} + \frac{2}{y^2}$, $x - 6y + 5 = 0$.

9. $M(x; y)$ nuqtadan $x=0, y=0, x - y + 1 = 0$ to'g'ri chiziqlargacha masofalar kvadratlarining yig'indisi eng kichik bo'lsa, bu nuqtani toping.

10.

x_i	0	1	2	3	4	5
y_i	5,2	5,7	5,3	4,9	3,6	1,8

21-variant

1. $x^2 + y^2 - 2z^2 + xy - 4z - 3xz - 4 = 0$, $M_0(3;2;1)$.

2. $z = x \sin y + y \cos x$, $z''_{xx} + z''_{yy} + z = 0$.

3. $z = e^{xy} \sqrt{y}$, $x = \ln v$, $y = v \sin u$, $\frac{\partial z}{\partial u}, \frac{\partial z}{\partial v} - ?$

4. $x^3 + y^2 + z = (x + y) \arctg z$.

5. $z = (xy) \cdot e^{xy}$.

6. $z = 9x^3 + 2y^2 - \ln(xy)$.

7. $z = xy^2(2 - x - y)$, $D: x = -3, y = 0, x + y + 1 = 0$.

8. $z = 8 - 4x + 3y$, $x^2 + y^2 - 25 = 0$.

9. Perimetri p ga teng bo'lgan tagi to'g'ri to'rtburchak ko'rinishiga va tepasi yarim aylana shakliga ega deraza romi orqali eng ko'p yorug'lik o'tayotgan bo'lsa, pomning o'lchamlarini toping.

10.

x_i	0	1	2	3	4	5
y_i	-0,3	-0,9	-0,1	0,6	2,2	5,0

22-variant

1. $z = x^2 + y^2 - 3xy + 3x - 2y - 5, \quad M_0(-1;2;-1).$

2. $z = \operatorname{tg}(xy) + \frac{x}{y}, \quad x^2 \cdot z''_{xx} - y^2 \cdot z''_{yy} + x \cdot z'_x - y \cdot z'_y = 0.$

3. $z = \frac{xy - 2y^2}{\sqrt{1+y}}, \quad y = xe^x, \quad \frac{dz}{dx} - ?$

4. $z^2 + 5 = z \ln(x + e^{-y}),$

5. $z = \cos(e^x + e^{-y}).$

6. $z = 2x^3 + 2y^3 - 6xy + 6.$

7. $z = 2x^2 + 3y^2 + 1, \quad D: y = \frac{3}{2}\sqrt{4-x^2}.$

8. $z = 6xy + 5x - 5y, \quad x^2 + y^2 - 2 = 0.$

9. Sirti S ga teng to'g'ri burchakli ochiq hovuz eng katta sig'imga ega bo'lsa, uning o'lchamlarini toping.

10.

x_i	0	1	2	3	4	5
y_i	1,2	1,7	1,2	0,4	-0,7	-2,8

23-variant

1. $6xy - 2x^2 - xy^2 - z^2 + 3x = 0, \quad M_0(1;2;3).$

2. $z = \ln(x + e^{-y}), \quad z'_x - z''_{xy} - e^y z''_{yy} = 0.$

3. $z = \ln \frac{x}{y}, \quad x = \sin \frac{u}{v}, \quad y = \sqrt{\frac{u}{v}}, \quad \frac{\partial z}{\partial u}, \frac{\partial z}{\partial v} - ?$

4. $x^3 + y^3 + z^3 = 3xy + 3xz + 3yz.$

5. $z = \frac{x+y}{x-y}.$

6. $z = 3x^2 + y - 2 \ln(x^3 y^4).$

7. $z = x^2 - 2xy - y^2 + 4x + 1, \quad D: x = -3, y = 0, x + y + 1 = 0.$

8. $z = 3 + \frac{1}{x} + \frac{1}{y}, \quad \frac{1}{x^2} + \frac{2}{y^2} - \frac{3}{8} = 0.$

9. Hajmi V ga teng konus eng kichik to'la sirtga ega bo'lsa, uning o'lchamlarini toping.

10.

x_i	0	1	2	3	4	5
y_i	-0,5	-0,7	0,	0,4	2,3	4,2

24-variant

1. $x^2 - y^2 + z^2 - yz - 4yx - 8x = 0, \quad M_0(1; -2; -1).$

2. $z = \ln(xy) + \ln \frac{x}{y}, \quad x^2 \cdot z'''_{xx} - y^2 z'''_{yy} + x \cdot z'_x - y \cdot z'_y = 0.$

3. $z = x \arctg(xy), \quad x = e^t + 1, \quad y = t^2 e^t, \quad \frac{dz}{dt} - ?$

4. $x \sin y + (y + z) \sin x = z^3$

5. $z = \frac{x}{y} \ln(xy).$

6. $z = xy^2 + \frac{4}{x} + \frac{4}{y}.$

7. $z = 1 - x^2 - y^2, \quad D: (x-1)^2 + (y-1)^2 = 1.$

8. $z = 5 + \frac{3}{x^2} + \frac{1}{2y^2}, \quad 6x + y - 14 = 0.$

9. Uchlari $x^2 + 4y^2 = 4$ ellipsning $A\left(\sqrt{3}; \frac{1}{2}\right), B\left(1; \frac{\sqrt{3}}{2}\right)$ va $C(x; y)$ nuqtalarida

yotgan uchburchakning yuzasi eng katta bo'lsa, $C(x; y)$ nuqtani toping.

10.

x_i	0	1	2	3	4	5
y_i	1,2	1,6	1,5	0,6	-1,2	-3,2

25-variant

1. $3x^2 - 4xy + 12xz - 3yz + z^2 + 15 = 0, \quad M_0(-1; -1; 2).$

2. $z = y^x, \quad x \cdot z'_x + z - y \cdot z''_{xy} = 0.$

3. $z = tg(xy), \quad x = \ln(u^2 + v^2), \quad y = \frac{v^2}{u^2}, \quad \frac{\partial z}{\partial u}, \frac{\partial z}{\partial v} - ?$

4. $xe^y + ye^z + ze^x = x + y + z$

5. $z = e^{\sin(x-y)}.$

6. $z = 3x + y^4 - 6 \ln x - 64 \ln y.$

7. $z = xy(12 - 4x - 3y), \quad D: x = 0, \quad y = 0, \quad 4x + 3y - 8 = 0.$

8. $z = x^2 + y^2 - 4, \quad 4x + 3y - 12 = 0.$

9. Radiusi R ga va balandligi H teng konusga ichki chizilgan silindr eng katta hajmga ega bo'lsa, silindrning o'lchamlarini toping.

10.

x_i	0	1	2	3	4	5
y_i	-0,6	0,6	0,5	-0,3	-1,8	-4,7

26-variant

1. $z = x^2 + y^2 + 2xy - 2x - 3y - 8, \quad M_0(2;3;4).$

2. $z = (y - x)\sin y + \cos x, \quad (x - y)z''_{xy} - z'_y + \sin y = 0.$

3. $z = tg \frac{x}{y}, \quad x = \frac{2v}{u+v}, \quad y = u^2 - 3v, \quad \frac{\partial z}{\partial u}, \frac{\partial z}{\partial v} - ?$

4. $z^2 + x^3 = y \ln \frac{xz}{y}.$

5. $z = \sin(x + y)\cos(x - y).$

6. $z = x^3 + y^3 + x^2y + y^2x - 6x - 6y.$

7. $z = 3x^2 + 3y^2 - x - y - 2, \quad D: x=5, y=0, x - y - 1 = 0.$

8. $z = x + 2y, \quad x^2 + y^2 - 5 = 0.$

9. Radiusi R ga va balandligi H teng konusga ichki chizilgan to'g'ri burchakli parallelpiped eng katta hajmga ega. Parallelpiped asosining yuzasini toping.

10.

x_i	0	1	2	3	4	5
y_i	-0,2	-2,3	-2,7	-1,6	-0,2	2,7

27-variant

1. $x^2 - xy + xz + 3yz + 2z^2 + 2 = 0, \quad M_0(1;1;-1).$

2. $z = \ln(x^2 + y^2 + 2x + 1), \quad z''_{xx} + z''_{yy} = 0.$

3. $z = \arccos \frac{2x}{y}, \quad x = \sin t, \quad y = \cos t, \quad \frac{dz}{dt} - ?$

4. $xz^5 + zy^3 - x^3 = yx.$

5. $z = (x + y)\ln(xy).$

6. $z = 4xy + \frac{1}{x} + \frac{16}{y}.$

7. $z = x^2 - 2xy + 2y^2 - 4y, \quad D: x=1, y=1, x + 2y - 8 = 0.$

8. $z = 1 - 4x - 8y, \quad x^2 - 8y^2 - 8 = 0.$

9. Radiusi R ga teng shardan tayyorlangan materialdan eng katta hajmga ega silindr yasalgan bo'lsa, silindrning balandligini toping.

10.

x_i	0	1	2	3	4	5
y_i	-0,3	-1,3	-1,6	-0,6	1,8	4,7

28-variant

1. $z = x^2 - y^2 + 6x + 3y - 2xy, \quad M_0(2;3;4).$

2. $z = \operatorname{tg} \frac{x}{y}, \quad z''_{xy} + \frac{x}{y} \cdot z''_{xx} + \frac{1}{y} \cdot z'_x = 0.$

3. $z = y^x, \quad y = \operatorname{arctg} x, \quad \frac{dz}{dx} - ?$

4. $yz^2 = x^2y + z \ln(xy).$

5. $z = x^3 \sin y + y^2 \cos x.$

6. $z = x^3 + 3y^3 - 3 \ln x - 48 \ln y.$

7. $z = 2xy - 3x^2 - 2y^2 + 5, \quad D: x = -1, y = -1, x + y - 5 = 0.$

8. $z = 4 + 5x + 12y, \quad x^2 + y^2 - 169 = 0.$

9. Asosi a ga va uchidagi burchagi α ga teng uchburchak eng katta yuzaga ega bo'lsa, uning qolgan ikki tomonini toping.

10.

x_i	0	1	2	3	4	5
y_i	-0,4	0,5	1,2	1,9	1,6	1,1

29-variant

1. $x^2 - 2y^2 - 2z^2 - xy - yz + 3 = 0, \quad M_0(2;1;1).$

2. $z = xy + x \sin \frac{x}{y}, \quad x \cdot z'_x + y \cdot z'_y - xy - z = 0.$

3. $u = x^2 y^3 z^4, \quad x = \ln(t+1), \quad y = t^2 + 1, \quad z = t^3, \quad \frac{du}{dt} - ?$

4. $e^{xyz} + xyz = x^2 + y.$

5. $z = e^{\cos(x-y)}.$

6. $z = x^3 + y^3 - 9xy + 6.$

7. $z = x^2 + 2xy - y^2 - 4x, \quad D: x = 0, y = 0, x + y + 2 = 0.$

8. $z = 3 + \frac{1}{x} + \frac{1}{2y^2}, \quad x - y - 2 = 0.$

9. Radiusi R ga teng sharga ichki chizilgan konus eng katta hajmga ega bo'lsa, konusning o'lchamlarini toping.

10.

x_i	0	1	2	3	4	5
y_i	-1,0	0,2	0,1	-0,7	-2,2	-5,1

30-variant

1. $x^3 + y^3 - z^2 - 2xyz - 5xy - 4y + 2 = 0, M_0(2;1;-3).$

2. $z = x \ln(x + y) + ye^{x+y}, \quad z''_{xx} - 2z''_{xy} + z''_{yy} = 0.$

3. $z = \arctg(xy), \quad x = \ln(v^2 - u^2), \quad y = vu^2, \quad \frac{\partial z}{\partial u}, \frac{\partial z}{\partial v} - ?$

4. $xz = e^{\frac{z}{y}} + x^3 + y^3.$

5. $z = e^{x-y} \sin(x + y).$

6. $z = x^2 y^2 + \frac{1}{x} + \frac{4}{y}.$

7. $z = x^2 + y^2, \quad D: 3|x| + 4|y| = 12.$

8. $z = \frac{4}{x^2} - \frac{1}{2y^2}, \quad x + y + 1 = 0.$

9. Asosining radiusi R ga va balandligi H ga teng konus shaklidagi suv bilan to'ldirilgan idishga kub (konus va kub asoslarining markazlari bu asoslarga perpendikular to'g'ri chiziqda yotadi) tashlangan. Kubning idish ichidagi qismi idishdan eng ko'p hajmdagi suv siqib chiqargan bo'lsa, kubning qirrasini toping.

10.

x_i	0	1	2	3	4	5
y_i	0,7	0,5	1,5	2,0	2,5	4,3

B. NAMUNAVIY VARIANT YECHIMI

1. Sirtga $M_0(x_0; y_0; z_0)$ nuqtada o'tkazilgan urinma tekislik va normal tenglamalarini tuzing.

1.30. $x^3 + y^3 - z^2 - 2xyz - 5xy - 4y + 2 = 0, M_0(2;1;-3).$

☞ $F(x, y, z) = x^3 + y^3 - z^2 - 2xyz - 5xy - 4y + 2 = 0$ belgilash kiritamiz.

U holda

$$F'_x(M_0) = 3x_0^2 - 2y_0z_0 - 5y_0 = 3 \cdot 2^2 - 2 \cdot 1 \cdot (-3) - 5 \cdot 1 = 13,$$

$$F'_y(M_0) = 3y_0^2 - 2x_0z_0 - 5x_0 - 4 = 3 \cdot 1^2 - 2 \cdot 2 \cdot (-3) - 5 \cdot 2 - 4 = 1,$$

$$F'_z(M_0) = -2z_0 - 2x_0y_0 = -2 \cdot (-3) - 2 \cdot 2 \cdot 1 = 2.$$

Bu qiymatlarni

$$F'_x(x_0, y_0, z_0)(x - x_0) + F'_y(x_0, y_0, z_0)(y - y_0) + F'_z(x_0, y_0, z_0)(z - z_0) = 0,$$

$$\frac{x - x_0}{F'_x(x_0, y_0, z_0)} = \frac{y - y_0}{F'_y(x_0, y_0, z_0)} = \frac{z - z_0}{F'_z(x_0, y_0, z_0)}$$

tenglamalarga qo'yib, topamiz:

1) urinma tekislik tenglamasi

$$13 \cdot (x - 2) + 1 \cdot (y - 1) + 2 \cdot (z + 3) = 0$$

yoki

$$13x + y + 2z - 21 = 0;$$

2) normal tenglamasi

$$\frac{x-2}{13} = \frac{y-1}{1} = \frac{z+3}{2}. \quad \odot$$

2. $z = f(x, y)$ funksiyaning berilgan tenglikni qanoatlantirishini ko'rsating.

2.30. $z = x \ln(x + y) + ye^{x+y}$, $z''_{xx} - 2z''_{xy} + z''_{yy} = 0$.

☞ Funksiyaning birinchi tartibli xususiy hosilalarini topamiz:

$$z'_x = \ln(x + y) + x \cdot \frac{1}{x + y} + y \cdot e^{x+y} = \ln(x + y) + \frac{x}{x + y} + ye^{x+y},$$

$$z'_y = x \cdot \frac{1}{x + y} + 1 \cdot e^{x+y} + y \cdot e^{x+y} = \frac{x}{x + y} + (1 + y)e^{x+y}.$$

Bundan

$$z''_{xx} = \frac{1}{x + y} + \frac{1}{x + y} - x \cdot \frac{1}{(x + y)^2} + y \cdot e^{x+y} = \frac{x + 2y}{(x + y)^2} + ye^{x+y},$$

$$z''_{xy} = \frac{1}{x + y} - x \cdot \frac{1}{(x + y)^2} + 1 \cdot e^{x+y} + y \cdot e^{x+y} = \frac{y}{(x + y)^2} + (1 + y)e^{x+y},$$

$$z''_{yy} = x \cdot \left(-\frac{1}{(x + y)^2} \right) + 1 \cdot e^{x+y} + (1 + y) \cdot e^{x+y} = -\frac{x}{(x + y)^2} + (2 + y)e^{x+y}.$$

z''_{xx} , z''_{xy} , z''_{yy} hosilalarni berilgan tenglamaga qo'yamiz:

$$\begin{aligned} z''_{xx} - 2z''_{xy} + z''_{yy} &= \frac{x + 2y}{x + y} + ye^{x+y} - 2 \cdot \left(\frac{y}{(x + y)^2} + (1 + y)e^{x+y} \right) + \\ &+ \left(-\frac{x}{(x + y)^2} + (2 + y)e^{x+y} \right) = \frac{x + 2y - 2y - x}{(x + y)^2} + e^{x+y}(y - 2 - 2y + 2 + y) = 0. \end{aligned}$$

Demak, $z = x \ln(x + y) + ye^{x+y}$ funksiya $z''_{xx} - 2z''_{xy} + z''_{yy} = 0$ tenglikni qanoatlantiradi. ☹

3. Murakkab funksiyaning ko'rsatilgan hosilalarini toping.

3.30. $z = \arctg(xy)$, $x = \ln(v^2 - u^2)$, $y = vu^2$, $\frac{\partial z}{\partial u}$, $\frac{\partial z}{\partial v} - ?$

☉ Funksiyalarning xususiy hosilalarini topamiz:

$$\frac{\partial z}{\partial x} = \frac{1}{1+(xy)^2} (xy)'_x = \frac{y}{1+x^2y^2}, \quad \frac{\partial z}{\partial y} = \frac{1}{1+(xy)^2} (xy)'_y = \frac{x}{1+x^2y^2},$$

$$\frac{\partial x}{\partial u} = -\frac{2u}{v^2 - u^2}, \quad \frac{\partial x}{\partial v} = \frac{2v}{v^2 - u^2}, \quad \frac{\partial y}{\partial u} = 2uv, \quad \frac{\partial y}{\partial v} = u^2.$$

U holda

$$\begin{aligned} \frac{\partial z}{\partial u} &= \frac{\partial z}{\partial x} \frac{\partial x}{\partial u} + \frac{\partial z}{\partial y} \frac{\partial y}{\partial u} = \frac{y}{1+x^2y^2} \cdot \left(-\frac{2u}{v^2 - u^2} \right) + \frac{x}{1+x^2y^2} \cdot (2uv) = \\ &= \frac{1}{1+x^2y^2} \cdot \left(-\frac{2u}{v^2 - u^2} \cdot y + 2uv \cdot x \right) \end{aligned}$$

yoki

$$\frac{\partial z}{\partial u} = \frac{2uv \cdot ((v^2 - u^2) \ln(v^2 - u^2) - u^2)}{(v^2 - u^2) \cdot (1 + u^2v^2 \ln^2(v^2 - u^2))}.$$

Shu kabi

$$\begin{aligned} \frac{\partial z}{\partial v} &= \frac{\partial z}{\partial x} \frac{\partial x}{\partial v} + \frac{\partial z}{\partial y} \frac{\partial y}{\partial v} = \frac{y}{1+x^2y^2} \cdot \left(\frac{2v}{v^2 - u^2} \right) + \frac{x}{1+x^2y^2} \cdot (u^2) = \\ &= \frac{1}{1+x^2y^2} \cdot \left(\frac{2v}{v^2 - u^2} \cdot y + u^2 \cdot x \right) \end{aligned}$$

yoki

$$\frac{\partial z}{\partial v} = \frac{u^2 \cdot (2v^2 - (v^2 - u^2) \ln(v^2 - u^2))}{(v^2 - u^2) \cdot (1 + u^2v^2 \ln^2(v^2 - u^2))}. \quad \ominus$$

4. Oshkormas ko'rinishda berilgan $z = z(x, y)$ funksiyaning birinchi tartibli xususiy hosilalarini toping.

4.30. $xz = e^{\frac{z}{y}} + x^3 + y^3$.

☉ Misolning shartiga ko'ra $F(x, y, z) = e^{\frac{z}{y}} + x^3 + y^3 - xz$.

Bundan

$$F'_x(x, y, z) = 3x^2 - z, \quad F'_y(x, y, z) = e^{\frac{z}{y}} \left(-\frac{z}{y^2} \right) + 3y^2 = \frac{3y^4 - ze^{\frac{z}{y}}}{y^2},$$

$$F'_z(x, y, z) = e^{\frac{z}{y}} \left(\frac{1}{y} \right) - x = \frac{e^{\frac{z}{y}} - xy}{y}.$$

U holda

$$\frac{\partial z}{\partial x} = -\frac{F'_x(x, y, z)}{F'_z(x, y, z)} = \frac{(3x^2 - z)y}{xy - e^{\frac{z}{y}}}, \quad \frac{\partial z}{\partial y} = -\frac{F'_y(x, y, z)}{F'_z(x, y, z)} = \frac{1}{y} \cdot \frac{3y^4 - ze^{\frac{z}{y}}}{xy - e^{\frac{z}{y}}}. \quad \ominus$$

5. Funksiyaning uchinchi tartibli differensialini toping.

5.30. $z = e^{x-y} \sin(x + y)$.

⊕ Funksiyalarning birinchi tartibli xususiy hosilalarini topamiz:

$$z'_x = e^{x-y} (\sin(x + y) + \cos(x + y)), \quad z'_y = e^{x-y} (\cos(x + y) - \sin(x + y)).$$

Bundan

$$\begin{aligned} z''_{x^2} &= e^{x-y} (\sin(x + y) + \cos(x + y) + \cos(x + y) - \sin(x + y)) = 2e^{x-y} \cos(x + y), \\ z''_{xy} &= e^{x-y} (-\sin(x + y) - \cos(x + y) + \cos(x + y) - \sin(x + y)) = -2e^{x-y} \sin(x + y), \\ z''_{y^2} &= e^{x-y} (-\cos(x + y) + \sin(x + y) - \sin(x + y) - \cos(x + y)) = -2e^{x-y} \cos(x + y). \end{aligned}$$

Funksiyalarning uchinchi tartibli xususiy hosilalarini topamiz:

$$\begin{aligned} z'''_{x^3} &= 2e^{x-y} (\cos(x + y) - \sin(x + y)), & z'''_{x^2y} &= -2e^{x-y} (\cos(x + y) + \sin(x + y)), \\ z'''_{y^2x} &= -2e^{x-y} (\cos(x + y) - \sin(x + y)), & z'''_{y^3} &= 2e^{x-y} (\cos(x + y) + \sin(x + y)). \end{aligned}$$

Uchinchi tartibli xususiy hosilalarning topilgan qiymatlarini

$$d^3 z = f'''_{x^3}(x, y)dx^3 + 3f'''_{x^2y}(x, y)dx^2 dy + 3f'''_{y^2x}(x, y)dxdy^2 + f'''_{y^3}(x, y)dy^3$$

formulaga qo'yib topamiz:

$$\begin{aligned} d^3 z &= (2e^{x-y} (\cos(x + y) - \sin(x + y)))dx^3 + 3(-2e^{x-y} (\cos(x + y) + \sin(x + y)))dx^2 dy + \\ &+ 3(-2e^{x-y} (\cos(x + y) - \sin(x + y)))dxdy^2 + (2e^{x-y} (\cos(x + y) + \sin(x + y)))dy^3 \end{aligned}$$

yoki

$$\begin{aligned} d^3 z &= 2e^{x-y} ((\cos(x + y) - \sin(x + y)) \cdot (dx^3 - 3dxdy^2) + \\ &+ ((\cos(x + y) + \sin(x + y)) \cdot (dy^3 - 3dx^2 dy)). \quad \ominus \end{aligned}$$

6. Funksiyani ekstremumga tekshiring.

6.30. $z = x^2 y^2 + \frac{1}{x} + \frac{4}{y}$.

⊕ Funksiyani ekstremumga belgilangan tartibda tekshiramiz.

1°. Funksiyaning birinchi tartibli xususiy hosilalarini topamiz:

$$\frac{\partial z}{\partial x} = 2xy^2 - \frac{1}{x^2}, \quad \frac{\partial z}{\partial y} = 2x^2 y - \frac{4}{y^2}.$$

2°. Statsionar nuqtalarni aniqlaymiz:

$$\begin{cases} 2x^3y^2 - 1 = 0, \\ x^2y^3 - 2 = 0. \end{cases}$$

Sistemani yechamiz: $P\left(\frac{1}{2}; 2\right)$.

3°. Ikkinchi tartibli xususiy hosilalarni topamiz:

$$\frac{\partial^2 z}{\partial x^2} = 2y^2 + \frac{2}{x^3}, \quad \frac{\partial^2 z}{\partial x \partial y} = 4xy, \quad \frac{\partial^2 z}{\partial y^2} = 2x^2 + \frac{8}{y^3}.$$

4°. $P\left(\frac{1}{2}; 2\right)$ statsionar nuqtada ikkinchi tartibli xususiy hosilalarni hisoblaymiz:

$$A = 2 \cdot 2^2 + 2 \cdot 2^3 = 24 > 0, \quad B = 4 \cdot \frac{1}{2} \cdot 2 = 4, \quad C = 2 \cdot \left(\frac{1}{2}\right)^2 + \frac{8}{2^3} = \frac{3}{2}.$$

5°. $P\left(\frac{1}{2}; 2\right)$ statsionar nuqtada $\Delta = AC - B^2 = 24 \cdot \frac{3}{2} - 4^2 = 20 > 0$.

Demak, $P\left(\frac{1}{2}; 2\right)$ nuqta minimum nuqta va $z_{\min} = \left(\frac{1}{2}\right)^2 \cdot 2^2 + 1 \cdot 2 + \frac{4}{2} = 5$. ◀

7. $z = f(x, y)$ funksiyaning D yopiq sohadagi eng katta va eng kichik qiymatlarini toping.

7.30. $z = x^2 + y^2$, $D: 3|x| + 4|y| = 12$.

◀ D soha $ABCE$ rombdan iborat (5-shakl).

1°. Funksiyaning D sohada yotgan kritik nuqtalarini topamiz:

$$\begin{cases} \frac{\partial z}{\partial x} = 2x = 0, \\ \frac{\partial z}{\partial y} = 2y = 0. \end{cases}$$

Bundan $x = 0, y = 0$.

Demak, $P_0(0; 0) = O(0; 0)$, $z(P_0) = 0$.

2°. Funksiyani soha chegarasida ekstremumga tekshiramiz. Soha chegarasi turli tenglamalar bilan aniqlanuvchi to'rtta qismdan tashkil topgani

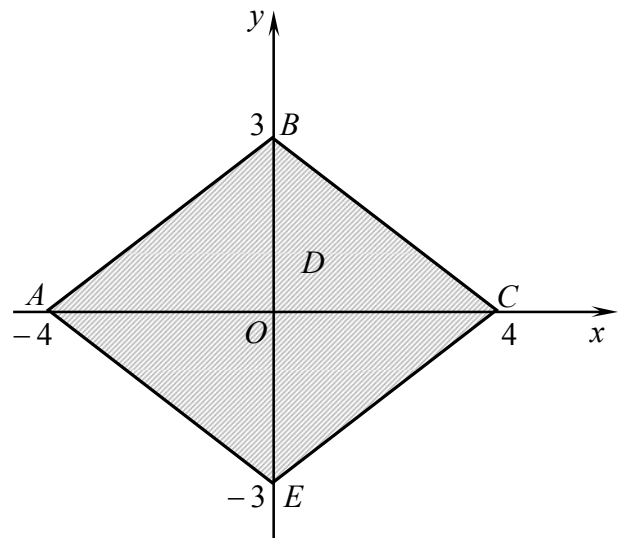

5-shakl.

sababli funksiyani har bir qismda ekstremumga alohida tekshiramiz.

1) AB to'g'ri chiziqda $-3x + 4y = 12$ yoki $y = \frac{12 + 3x}{4}$ va

$$z = x^2 + \left(\frac{3x + 12}{4}\right)^2 \quad (-4 \leq x \leq 0).$$

U holda

$$z'_x = 2x + 2\left(\frac{3x + 12}{4}\right) \cdot \frac{3}{4} = 0 \text{ dan } x = -\frac{36}{25}. \quad y = \frac{12 + 3x}{4} \text{ dan } y = \frac{48}{25}.$$

$$\text{Demak, } z\left(-\frac{36}{25}, \frac{48}{25}\right) = \frac{144}{25}.$$

AB to'g'ri chiziqning chetki nuqtalarida: $z(A) = z(-4, 0) = 16$, $z(B) = z(0, 3) = 9$.

2) BC to'g'ri chiziqda $3x + 4y = 12$ yoki $y = \frac{12 - 3x}{4}$.

$$\text{Bundan } z = x^2 + \left(\frac{12 - 3x}{4}\right)^2 \quad (0 \leq x \leq 4).$$

U holda $z'_x = 2x + 2\left(\frac{12 - 3x}{4}\right) \cdot \left(-\frac{3}{4}\right) = 0$ dan $x = \frac{36}{25}$. $y = \frac{12 - 3x}{4}$ dan $y = \frac{48}{25}$.

$$\text{Demak, } z\left(\frac{36}{25}, \frac{48}{25}\right) = \frac{144}{25}.$$

BC to'g'ri chiziqning chetki nuqtalarida: $z(B) = 9$, $z(C) = z(4, 0) = 16$.

3) CE to'g'ri chiziqda $3x - 4y = 12$ yoki $y = -\frac{12 - 3x}{4}$.

$$\text{Bundan } z = x^2 + \left(\frac{12 - 3x}{4}\right)^2 \quad (0 \leq x \leq 4).$$

U holda

$$z'_x = 2x + 2\left(\frac{12 - 3x}{4}\right) \cdot \left(-\frac{3}{4}\right) = 0 \text{ dan } x = \frac{36}{25}. \quad y = -\frac{12 - 3x}{4} \text{ dan } y = -\frac{48}{25}.$$

$$\text{Demak, } z\left(\frac{36}{25}, -\frac{48}{25}\right) = \frac{144}{25}.$$

BC to'g'ri chiziqning chetki nuqtalarida: $z(C) = 16$, $z(E) = z(0, -3) = 9$.

4) EA to'g'ri chiziqda $-3x - 4y = 12$ yoki $y = -\frac{12 + 3x}{4}$.

$$\text{Bundan } z = x^2 + \left(\frac{12 + 3x}{4}\right)^2 \quad (-4 \leq x \leq 0).$$

U holda

$$z'_x = 2x + 2\left(\frac{12+3x}{4}\right) \cdot \left(\frac{3}{4}\right) = 0 \text{ dan } x = -\frac{36}{25}, \quad y = -\frac{12+3x}{4} \text{ dan } y = -\frac{48}{25}.$$

$$\text{Demak, } z\left(-\frac{36}{25}, -\frac{48}{25}\right) = \frac{144}{25}.$$

BC to'g'ri chiziqning chetki nuqtalarida: $z(E) = 9$, $z(A) = 16$.

3°. Funksiyaning hisoblangan qiymatlarini taqqoslaymiz.

Demak,

$$z_{eng \text{ katta}} = z(\pm 4, 0) = 16 \quad \text{va} \quad z_{eng \text{ kichik}} = z(0, 0) = 0. \quad \ominus$$

8. $z = f(x, y)$ funksiyalarning $\varphi(x, y) = 0$ tenglama bilan bog'langanlik shartidagi ekstremumlarini toping.

$$\mathbf{8.30.} \quad z = \frac{4}{x^2} - \frac{1}{2y^2}, \quad x + y + 1 = 0.$$

⊕ Funksiyani Lagranj ko'paytuvchilari usulu bilan ekstremumga tekshiramiz.

1°. Lagranj funksiyasini tuzamiz:

$$F(x, y, z) = f(x, y) + \lambda \varphi(x, y) = \frac{4}{x^2} - \frac{1}{2y^2} + \lambda(x + y + 1).$$

Bundan

$$F'_x = -\frac{8}{x^3} + \lambda, \quad F'_y = \frac{1}{y^3} + \lambda, \quad F'_\lambda = x + y + 1.$$

2°. Shartli ekstremumning zaruruy shartiga ko'ra

$$\begin{cases} -8 + \lambda x^3 = 0, \\ 1 + \lambda y^3 = 0, \\ x + y + 1 = 0. \end{cases}$$

Sistemani yechamiz: $x = -2$, $y = 1$, $\lambda = -1$. Demak, $P_0(-2; 1)$ mumkin bo'lgan shartli ekstremum nuqta.

3°. Δ determinantga qo'yiladigan xususiy hosilalarni topamiz:

$$\varphi'_x = 1, \quad \varphi'_y = 1, \quad F''_{x^2} = \frac{24}{x^4}, \quad F''_{xy} = 0, \quad F''_{y^2} = -\frac{3}{y^4}.$$

Bundan

$$\varphi'_x(P_0) = 1, \quad \varphi'_y(P_0) = 1, \quad F''_{x^2}(P_0) = \frac{24}{(-2)^4} = \frac{3}{2}, \quad F''_{xy}(P_0) = 0, \quad F''_{y^2}(P_0) = -\frac{3}{1^4} = -3.$$

U holda

$$\Delta = - \begin{vmatrix} 0 & 1 & 1 \\ 1 & \frac{3}{2} & 0 \\ 1 & 0 & -3 \end{vmatrix} = -\frac{3}{2} < 0.$$

Demak, $P_0(-2;1)$ nuqtada funksiya shartli maksimumga ega:

$$z_{\max} = \frac{4}{(-2)^2} - \frac{1}{2 \cdot 1^2} = \frac{1}{2}. \quad \odot$$

9. Eng katta va eng kichik qiymatlarni topishga oid amaliy masalalarni yeching.

9.30. Asosining radiusi R ga va balandligi H ga teng konus shaklidagi idish suyuqlik bilan to'ldirilgan. Idishga tashlangan sharning idish ichidagi qismi idishdan eng ko'p miqdorda suyuqlik siqib chiqargan bo'lsa, sharning radiusini toping.

\odot Sharning idishdan tashqaridagi qismi, ya'ni shar sektorining balandligi $CE = x$ bo'lsin (6-shakl). U holda bu sigmentning hajmi

$$V_{cek} = \frac{\pi}{3}(3x^2r - x^3) \text{ ga teng bo'ladi.}$$

Sharning idish ichidagi qismining hajmini topamiz:

$$V = V_{sh} - V_{cek} = \frac{4}{3}\pi r^3 - \frac{\pi}{3}(3x^2r - x^3) = \frac{\pi}{3}(4r^3 - 3rx^2 + x^3).$$

Sharning idishdan siqib chiqaradigan suyuqlik miqdori V hajmga bog'liq bo'ladi. Sharning idish ichidagi qismi idishdan eng ko'p miqdorda suyuqlik siqib chiqaririshi uchun $4r^3 - 3rx^2 + x^3$ ifoda maksimumga erishishi kerak. Bunda shar bilan idishning o'lchamlari uzviy bog'lanishga ega bo'ladi. Shu bog'lanishni aniqlaymiz.

6-shakldan topamiz:

$$S_{\triangle ABC} = \frac{1}{2}BC \cdot AC = \frac{1}{2}RH, \quad S_{\triangle ABD} = \frac{1}{2}AB \cdot KD = \frac{1}{2}lr,$$

$$S_{\triangle DBC} = \frac{1}{2}BC \cdot DC = \frac{1}{2}R(ED - x) = \frac{1}{2}R(r - x).$$

Shu bilan birga $S_{\triangle ABC} = S_{\triangle ABD} + S_{\triangle DBC}$ yoki

$$\frac{1}{2}RH = \frac{1}{2}lr + \frac{1}{2}R(r - x).$$

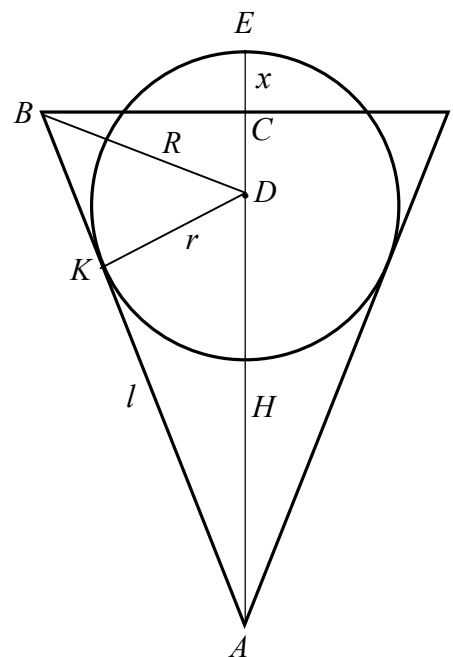

6-shakl

Bundan $(l + R)r - Rx - RH = 0$.

Shunday qilib, sharning idish ichidagi qismi idishdan eng ko'p miqdorda suyuqlik siqib chiqaririshini topish uchun $z(r, x) = 4r^3 - 3rx^2 + x^3$ funksiyaning $\varphi(r, x) = (l + R)r - Rx - RH = 0$ bog'lanish tenglamasi bilan bog'langanlik shartidagi maksimumini topish kerak bo'ladi. Bu masalani Lagranj ko'paytuvchilar usuli bilan yechamiz.

1°. Lagranj funksiyasini tuzamiz:

$$F(r, x, z) = 4r^3 - 3rx^2 + x^3 + \lambda((l + R)r - Rx - RH).$$

Bundan

$$F'_r = 12r^2 - 3x^2 + \lambda(l + R), \quad F'_x = 3x^2 - 6rx - \lambda R, \quad F'_\lambda = (l + R)r - Rx - RH.$$

2°. Shartli ekstremumning zaruruy shartiga ko'ra

$$\begin{cases} 3(4r^2 - x^2) + \lambda l + \lambda R = 0, \\ 3(x^2 - 2rx) - \lambda R = 0, \\ (l + R)r - Rx - RH = 0 \end{cases} \Rightarrow \begin{cases} 6r(2r - x) + \lambda l = 0, \\ 3x(2r - x) + \lambda R = 0, \\ (l + R)r - Rx - RH = 0. \end{cases}$$

Sistemani yechib, r ni topamiz:

$$r = \frac{RH\sqrt{R^2 + H^2}}{(\sqrt{R^2 + H^2} - R) \cdot (\sqrt{R^2 + H^2} + 2R)}.$$

Demak, radiusning bu qiymatida idishga tashlangan shar idishdan eng ko'p miqdorda suyuqlik siqib chiqaradi. 

10. x argument va $y = f(x)$ funksiyaning tajriba natijasida olingan qiymatlari jadvalda berilgan. x va y o'zgaruvchilar orasidagi $y = ax^2 + bx + c$ empirik funksiyani eng kichik kvadratlar usuli bilan toping. Tajriba nuqtalarini va empirik funksiyani to'g'ri chiziqli dekart koordinatalar sistemasida tasvirlovchi chizmani chizig.

10.30.

x_i	0	1	2	3	4	5
y_i	0,7	0,5	1,5	2,0	2,5	4,3

 Empirik formulani $y = ax^2 + bx + c$ ko'rinishda izlaymiz.

Bu funksiyaning a, b va c parametrlarini

$$\begin{cases} a \cdot \sum_{i=1}^n x_i^4 + b \cdot \sum_{i=1}^n x_i^3 + c \cdot \sum_{i=1}^n x_i^2 = \sum_{i=1}^n x_i^2 y_i, \\ a \cdot \sum_{i=1}^n x_i^3 + b \cdot \sum_{i=1}^n x_i^2 + c \cdot \sum_{i=1}^n x_i = \sum_{i=1}^n x_i y_i, \\ a \cdot \sum_{i=1}^n x_i^2 + b \cdot \sum_{i=1}^n x_i + c \cdot n = \sum_{i=1}^n y_i \end{cases}$$

tenglamalar sistemasidan topamiz.

Qulaylik uchun hisoblarni jadvalda bajaramiz:

i	x_i	x_i^2	x_i^3	x_i^4	y_i	$x_i y_i$	$x_i^2 y_i$
1	0	0	0	0	0,7	0	0
2	1	1	1	1	0,5	0,5	0,5
3	2	4	8	16	1,5	3,0	6,0
4	3	9	27	81	2,0	6,0	18,0
5	4	16	64	256	2,5	10,0	40,0
6	5	25	125	625	4,3	21,5	107,5
Σ	15	55	225	979	11,5	41	172

U holda sistema

$$\begin{cases} 979a + 225b + 55c = 172, \\ 225a + 55b + 15c = 41, \\ 55a + 15b + 6c = 11,5 \end{cases}$$

ko‘rinishga keladi.

Uni Kramer formulalari

bilan yechamiz:

$$\Delta = \begin{vmatrix} 979 & 225 & 55 \\ 225 & 55 & 15 \\ 55 & 15 & 6 \end{vmatrix} = 3920,$$

$$\Delta_b = \begin{vmatrix} 979 & 172 & 55 \\ 225 & 41 & 15 \\ 55 & 11,5 & 6 \end{vmatrix} = -56,$$

$$\Delta_c = \begin{vmatrix} 979 & 225 & 172 \\ 225 & 55 & 41 \\ 55 & 15 & 11,5 \end{vmatrix} = 2520,$$

$$a = \frac{560}{3920} = 0,14, \quad b = -\frac{56}{3920} = -0,01, \quad c = \frac{2520}{3920} = 0,64.$$

Demak, izlanayotgan funksiya

$$y = 0,1405x^2 - 0,01x + 0,64.$$

Tajriba nuqtalarini va empirik funksiyaning to‘g‘ri burchakli dekart koordinatalar sistemasida tasvirlovchi chizmani chizamiz (7-shakl). 

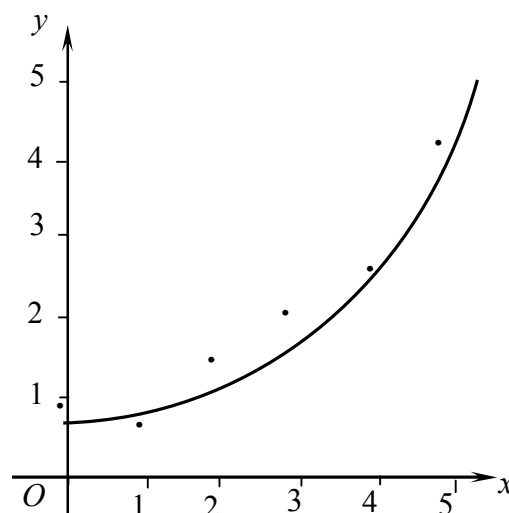

7-shakl.

II bob

BIR NECHA O‘ZGARUVCHI FUNKSIYALARINING INTEGRAL HISOBI

2.1. IKKI KARRALI INTEGRAL

Ikki karrali integral. Ikki karrali integralni dekart koordinatalarida hisoblash. Ikki karrali integralda o‘zgaruvchini almashtirish. Ikki karrali integralning tatbiqlari

2.1.1. Oxy tekislikning yopiq D sohasida $z = f(x, y)$ funksiya aniqlangan va uzluksiz bo‘lsin.

D sohani ixtiyoriy ravishda umumiy ichki nuqtalarga ega bo‘lmagan va yuzalari ΔS_i ga teng bo‘lgan n ta $D_i (i = \overline{1, n})$ elementar sohalarga bo‘lamiz. Har bir D_i sohada ixtiyoriy $P(x_i; y_i)$ nuqtani tanlaymiz, $z = f(x, y)$ funksiyaning bu nuqtadagi qiymati $f(x_i, y_i)$ ni hisoblab, uni ΔS_i ga ko‘paytiramiz va barcha bunday ko‘paytmalarning yig‘indisini tuzamiz:

$$I_n = \sum_{i=1}^n f(x_i, y_i) \Delta S_i. \quad (1.1)$$

Bu yig‘indiga $f(x, y)$ funksiyaning D sohadagi integral yig‘indisi deyiladi.

D_i soha chegaraviy nuqtalari orasidagi masofalarning eng kattasiga shu yuzaning diametri deyiladi va d_i bilan belgilanadi, bunda $n \rightarrow \infty$ da $d_i \rightarrow 0$.

☐ Agar (1.1) integral yig‘indining $\max d_i \rightarrow 0$ dagi chekli limiti D sohani bo‘laklarga bo‘lish usuliga va bu bo‘laklarda $P(x_i; y_i)$ nuqtani tanlash usuliga bog‘liq bo‘lmagan holda mavjud bo‘lsa, bu limitga $f(x, y)$ funksiya *D soha bo‘yicha olingan ikki karrali integral* deyiladi va $\iint_D f(x, y) dS$ bilan belgilanadi:

$$\iint_D f(x, y) dS = \lim_{\max d_i \rightarrow 0} \sum_{i=1}^n f(x_i, y_i) \Delta S_i, \quad (1.2)$$

yoki

$$\iint_D f(x, y) dx dy = \lim_{\max d_i \rightarrow 0} \sum_{i=1}^n f(x_i, y_i) \Delta x_i \cdot \Delta y_i. \quad (1.3)$$

1-teorema (*funksiya integrallanuvchi bo‘lishining etarli sharti*). Agar $z = f(x, y)$ funksiya chegaralangan yopiq D sohada uzluksiz bo‘lsa, u holda u D sohada integrallanuvchi bo‘ladi.

Ikki karrali integral quyidagi xossalarga ega.

$$1^{\circ}. \iint_D kf(x,y)dS = k \iint_D f(x,y)dS, \quad k \in R.$$

$$2^{\circ}. \iint_D (f(x,y) \pm g(x,y))dS = \iint_D f(x,y)dS \pm \iint_D g(x,y)dS.$$

3^o. Agar D soha umumiy ichki nuqtaga ega bo'lmagan chekli sondagi D_1, D_2, \dots, D_n sohalardan tashkil topgan bo'lsa, u holda

$$\iint_D f(x,y)dS = \iint_{D_1} f(x,y)dS + \iint_{D_2} f(x,y)dS + \dots + \iint_{D_n} f(x,y)dS.$$

4^o. Agar D sohada $f(x,y) \geq 0$ ($f(x,y) \leq 0$) bo'lsa, u holda

$$\iint_D f(x,y)dS \geq 0 \left(\iint_D f(x,y)dS \leq 0 \right).$$

5^o. Agar D sohada $f(x,y) \geq g(x,y)$ ($f(x,y) \leq g(x,y)$) bo'lsa, u holda

$$\iint_D f(x,y)dS \geq \iint_D g(x,y)dS \left(\iint_D f(x,y)dS \leq \iint_D g(x,y)dS \right).$$

6^o. Agar D sohada $f(x,y)$ funksiya uzluksiz bo'lsa, u holda shunday $P_0(x_0; y_0) \in D$ nuqta topiladiki

$$\iint_D f(x,y)dS = f(x_0, y_0)S.$$

Bunda $f(x_0, y_0) = \frac{1}{S} \iint_D f(x,y)dS$ qiymatga $f(x,y)$ funksiyaning D sohadagi o'rta qiymati deyiladi.

7^o. Agar D sohada $f(x,y)$ funksiya uzluksiz bo'lsa, u holda

$$mS \leq \iint_D f(x,y)dS \leq MS$$

bo'ladi, bu yerda m va M funksiyaning D sohadagi eng kichik va eng katta qiymatlari.

2.1.2. $y = \varphi_1(x)$ va $y = \varphi_2(x)$ funksiyalarning grafiklari hamda $x = a$ va $x = b$ to'g'ri chiziqlar bilan chegaralangan egri chizikli trapetsiyadan iborat D soha berilgan bo'lsin.

Agar D sohaning ichki nuqtasidan o'tuvchi Oy (Ox) o'qqa parallel har qanday to'g'ri chiziq L chegarani ikkita nuqtada kesib o'tsa va sohaning kirish (CNE) va

chiqish (AMB) chegaralarining har biri alohida tenglama bilan berilgan bo'lsa D sohaga Oy (Ox) o'q yo'nalishi bo'yicha *muntaзам soha* deyiladi (1-shakl).

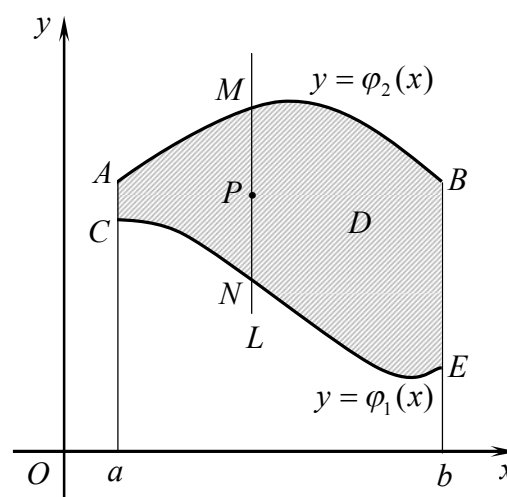

1-shakl.

Oy (Ox) o'q yo'nalishi bo'yicha muntazam soha quyidagicha belgilanadi:

$$D = \{(x; y) \in R^2 : a \leq x \leq b, \varphi_1(x) \leq y \leq \varphi_2(x)\}$$

$$(D = \{(x; y) \in R^2 : \psi_1(y) \leq x \leq \psi_2(y), c \leq y \leq d\}).$$

$D = \{(x; y) \in R^2 : a \leq x \leq b, \varphi_1(x) \leq y \leq \varphi_2(x)\}$ sohada uzluksiz $f(x, y)$ funksiyaning $\iint_D f(x, y) dx dy$ ikki karrali integrali

$$\iint_D f(x, y) dx dy = \int_a^b dx \int_{\varphi_1(x)}^{\varphi_2(x)} f(x, y) dy \quad (1.4)$$

formula bilan topiladi.

\Rightarrow (1.4) formulada $\int_{\varphi_1(x)}^{\varphi_2(x)} f(x, y) dy$ *ichki integral* deb ataladi. Ichki

integralda x o'zgarmas hisoblanadi va integrallash y o'zgaruvchi bo'yicha bajariladi. Ichki integralni hisoblash natijasida umuman olganda x ning funksiyasi hosil bo'ladi. Bu funksiya tashqi integral uchun integral osti funksiyasi bo'ladi. Tashqi integral x o'zgaruvchi bo'yicha a dan b gacha hisoblanadi.

\Rightarrow Agar D nomuntazam soha bo'lsa, u bir nechta muntazam sohalarga ajratiladi va bu sohalarning har birida ikki karrali integrallar hisoblanadi va keyin ular qo'shiladi.

$D = \{(x; y) \in R^2 : \psi_1(y) \leq x \leq \psi_2(y), c \leq y \leq d\}$ integrallash sohasi uchun

$$\iint_D f(x, y) dx dy = \int_c^d dy \int_{\psi_1(y)}^{\psi_2(y)} f(x, y) dx \quad (1.5)$$

bo'ladi.

\Rightarrow Ikki karrali integralda integrallash tartibini o'zgartirish mumkin:

$$\int_a^b dx \int_{\varphi_1(x)}^{\varphi_2(x)} f(x, y) dy = \int_c^d dy \int_{\psi_1(y)}^{\psi_2(y)} f(x, y) dx.$$

1 – misol. Ikki karrali integrallarni hisoblang:

1) $\int_0^1 \int_1^2 \frac{1}{(x+y)^2} dx dy;$

2) $\int_0^{2\pi} \int_1^{\sin x} \frac{y}{2} dx dy;$

3) $\int_0^4 \int_y^2 (3x^2 - 2xy + y) dx dy;$

4) $\int_0^1 \int_{\sqrt{y}}^{2-y} x dx dy.$

\ominus 1) Integrallash chegaralari o'zgarmas bo'lgani sababli ichki integralni istalgan o'zgaruvchi bo'yicha hisoblash mumkin. Integralni quyidagicha yozib olamiz:

$$\int_0^1 dx \int_1^2 \frac{1}{(x+y)^2} dy.$$

x ni o'zgarimas deb, ichki integralni y bo'yicha hisoblaymiz:

$$-\int_0^1 \frac{1}{x+y} \Big|_1^2 dx = -\int_0^1 \left(\frac{1}{x+2} - \frac{1}{x+1} \right) dx.$$

Endi tashqi integralni x bo'yicha hisoblaymiz:

$$\int_0^1 \left(\frac{1}{x+1} - \frac{1}{x+2} \right) dx = (\ln|x+1| - \ln|x+2|) \Big|_0^1 = \ln \left| \frac{x+1}{x+2} \right| \Big|_0^1 = \ln \frac{2}{3} - \ln \frac{1}{2} = \ln \frac{4}{3}.$$

2) Ichki integralning chegarasi x ga bog'liq bo'lgani sababli avval ichki integralni y bo'yicha va keyin tashqi integralni x bo'yicha hisoblaymiz:

$$\begin{aligned} \int_0^{2\pi} \frac{y^2}{4} \Big|_0^{2+\sin x} dx &= \frac{1}{4} \int_0^{2\pi} (2 + \sin x)^2 dx = \frac{1}{4} \int_0^{2\pi} (4 + 4\sin x + \sin^2 x) dx = \\ &= \frac{1}{4} \cdot 4x \Big|_0^{2\pi} - \frac{1}{4} \cdot 4\cos x \Big|_0^{2\pi} + \frac{1}{4} \int_0^{2\pi} \frac{1 - \cos 2x}{2} dx = \\ &= 2\pi - (\cos 2\pi - \cos 0) + \frac{1}{8} x \Big|_0^{2\pi} - \frac{1}{8} \cdot \frac{\sin 2x}{2} \Big|_0^{2\pi} = 2\pi + \frac{\pi}{4} - 0 = \frac{9\pi}{4}. \end{aligned}$$

3) Ichki integralni x bo'yicha, tashqi integralni y bo'yicha hisoblaymiz:

$$\begin{aligned} \int_0^4 dy \int_y^2 (3x^2 - 2xy + y) dx &= \int_0^4 (x^3 - yx^2 + yx) \Big|_y^2 dy = \int_0^4 ((8 - 4y + 2y) - (y^3 - y^3 + y^2)) dy = \\ &= \int_0^4 (8 - 2y - y^2) dy = \left(8y - y^2 - \frac{y^3}{3} \right) \Big|_0^4 = 32 - 16 - \frac{64}{3} = -\frac{16}{3}. \end{aligned}$$

4) Ichki integralni x bo'yicha, tashqi integralni y bo'yicha hisoblaymiz:

2-misol. $\iint_D (x-y) dx dy$ integralni hisoblang, bu yerda D : uchlari $A(1;1)$, $B(3;1)$, $C(3;3)$ nuqtalarda joylashgan uchburchak (2-shakl).

\Rightarrow D soha chapdan o'ngdan $x=1$ va $x=3$ to'g'ri chiziqlar bilan, quyidan AB ($y=1$) to'g'ri chiziq bilan va yuqoridan AC ($y=x$) to'g'ri chiziq bilan chegaralangan. Shu sababli integralni quyidagicha hisoblaymiz:

$$\begin{aligned} \iint_D (x-y) dx dy &= \int_1^3 dx \int_1^x (x-y) dy = \int_1^3 \left(xy - \frac{y^2}{2} \right) \Big|_1^x dx = \\ &= \int_1^3 \left(\frac{x^2}{2} - x + \frac{1}{2} \right) dx = \left(\frac{x^3}{6} - \frac{x^2}{2} + \frac{x}{2} \right) \Big|_1^3 = \left(\frac{9}{2} - \frac{9}{2} + \frac{3}{2} \right) - \left(\frac{1}{6} - \frac{1}{2} + \frac{1}{2} \right) = \frac{4}{3}. \end{aligned}$$

3-misol. $\iint_D x^2 dx dy$ integralni hisoblang, bu yerda $D: y = x^2 + x - 2$ va $y = x + 2$ chiziqlar bilan chegaralangan soha.

☞ D sohani tuzamiz. Buning uchun berilgan tenglamalarni birgalikda yechib, chiziqlarning kesishish nuqtalarini topamiz:

$$x^2 + x - 2 = x + 2 \quad \text{dan} \quad x = \pm 2.$$

Demak, berilgan chiziqlar $A(-2;0)$ va $B(2;4)$ nuqtalarda kesishadi. Parabola va $y = x + 2$ to'g'ri chiziqni A nuqtadan B nuqttagacha chizamiz (3-shakl).

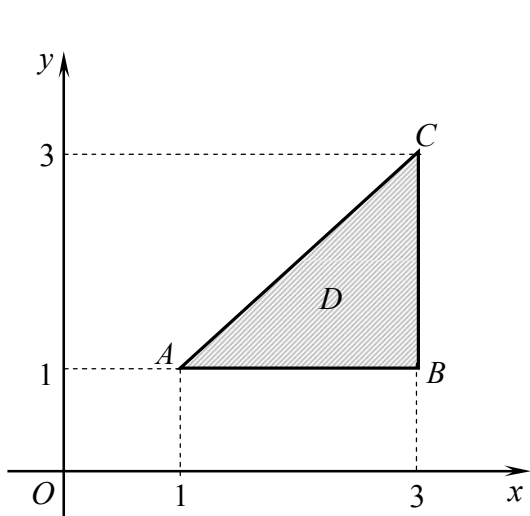

2-shakl.

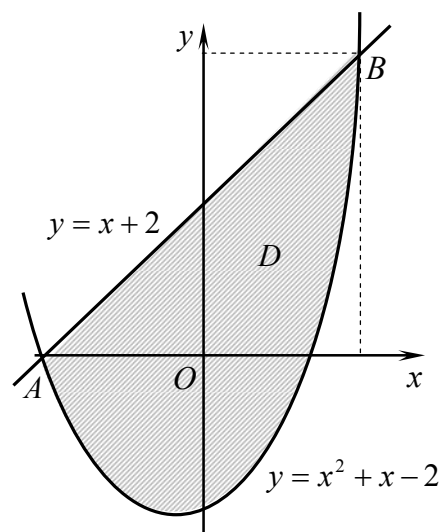

3-shakl.

D soha Oy o'qi bo'yicha muntazam. Shu sababli

$$\begin{aligned} \iint_D x^2 dx dy &= \int_{-2}^2 x^2 dx \int_{x^2+x-2}^{x+2} dy = \int_{-2}^2 x^2 y \Big|_{x^2+x-2}^{x+2} dx = \\ &= \int_{-2}^2 x^2 (4 - x^2) dx = \int_{-2}^2 (4x^2 - x^4) dx = \left(\frac{4x^3}{3} - \frac{x^5}{5} \right) \Big|_{-2}^2 = 2 \left(\frac{32}{3} - \frac{32}{5} \right) = \frac{128}{15}. \quad \text{☞} \end{aligned}$$

4-misol. $\iint_D \frac{x^2}{y^2} dx dy$ integralni hisoblang, bu yerda $D: y = -x, y = x^2$ va $y = 1$ chiziqlar bilan chegaralangan soha (4-shakl).

☞ D soha Ox o'qqa nisbatan muntazam. Shu sababli

$$\begin{aligned} \iint_D \frac{x^2}{y^2} dx dy &= \int_0^1 \frac{1}{y^2} dy \int_{-y}^{\sqrt{y}} x^2 dx = \int_0^1 \frac{1}{y^2} \cdot \frac{x^3}{3} \Big|_{-y}^{\sqrt{y}} dy = \frac{1}{3} \int_0^1 \frac{y\sqrt{y} - y^3}{y^2} dy = \\ &= \frac{1}{3} \int_0^1 \frac{dy}{\sqrt{y}} - \frac{1}{3} \int_0^1 y dy = \left(\frac{2}{3} \sqrt{y} - \frac{y^2}{6} \right) \Big|_0^1 = \frac{1}{2}. \quad \text{☞} \end{aligned}$$

5 – misol. $\iint_D x dx dy$ integralni hisoblang, bu yerda D : sikloidaning bir arkasi.

☞ Sikloidaning parametrik tenglamasini olamiz:

$$\begin{cases} x = a(t - \sin t), \\ y = a(1 - \cos t), \quad a > 0 \end{cases}$$

Sikloidaning bir arkasi uchun t parametr 0 dan 2π gacha o'zgaranda x o'zgaruvchi 0 dan $2\pi a$ gacha o'zgaradi. y funksiyani $y = f(x)$ ko'rinishda bo'lsin deb, berilgan integralning o'zgaruvchilarini ajratib yozib olamiz:

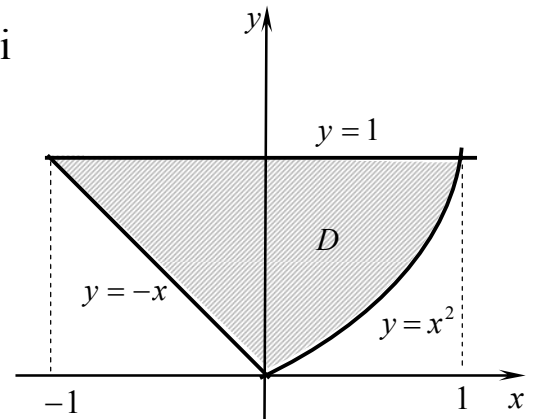

4-shakl.

$$I = \iint_D x dx dy = \int_0^{2\pi a} x dx \int_0^{f(x)} dy.$$

$dx = a(1 - \cos t)dt$, $dy = a \sin t dt$ differensiallarni hisobga olib, tashqi integralda t o'zgaruvchiga o'tamiz:

$$\begin{aligned} I &= \int_0^{2\pi} a(t - \sin t) a(1 - \cos t) dt \int_0^{a(1 - \cos t)} dy = a^3 \int_0^{2\pi} (t - \sin t)(1 - \cos t)^2 dt = \\ &= a^3 \int_0^{2\pi} (t - 2t \cos t + t \cos^2 t - \sin t + \sin 2t - \sin t \cos^2 t) dt = \\ &= a^3 \left(\frac{t^2}{2} - 2t \sin t - 2 \cos t + \frac{t}{2} \left(t + \frac{1}{2} \sin 2t \right) - \frac{1}{4} \left(t^2 - \frac{1}{2} \cos 2t \right) \right) \Big|_0^{2\pi} + \\ &\quad + a^3 \left(\cos t - \frac{1}{2} \cos 2t + \frac{1}{3} \cos^3 t \right) \Big|_0^{2\pi} = 3\pi^2 a^3. \quad \text{☞} \end{aligned}$$

6-misol. $\int_0^{\frac{1}{2}} dy \int_{\sqrt{1-2y}}^{\sqrt{1-y^2}} f(x, y) dx + \int_{\frac{1}{2}}^1 dy \int_0^{\sqrt{1-y^2}} f(x, y) dx$ integralda integrallash tartibini

o'zgartiring.

☞ Integrallash sohasi quyidagi tengsizliklar sistemalari bilan aniqlanuvchi D_1 va D_2 sohalardan tashkil topadi:

$$D_1 : \begin{cases} 0 \leq y \leq \frac{1}{2}, \\ \sqrt{1-2y} \leq x \leq \sqrt{1-y^2}, \end{cases} \quad D_2 : \begin{cases} \frac{1}{2} \leq x \leq 1, \\ 0 \leq x \leq \sqrt{1-y^2}. \end{cases}$$

Integrallash sohasi x o'zgaruvchi 0 dan 1 gacha o'zgaranda quyidan

$y = \frac{1-x^2}{2}$ va yuqoridan $y = \sqrt{1-x^2}$ chiziqlar bilan chegaralangan egri chiziqli trapetsiyadan iborat bo'ladi (5-shakl).

Demak, $D: \begin{cases} 0 \leq x \leq 1, \\ \frac{1-x^2}{2} \leq y \leq \sqrt{1-x^2}. \end{cases}$ U holda

$$\int_0^{\frac{1}{2}} dy \int_{\sqrt{1-2y}}^{\sqrt{1-y^2}} f(x,y) dx + \int_{\frac{1}{2}}^1 dy \int_0^{\sqrt{1-y^2}} f(x,y) dx = \int_0^1 dx \int_{\frac{1-x^2}{2}}^{\sqrt{1-x^2}} f(x,y) dy. \quad \text{☞}$$

2.1.3. $z = f(x, y)$ funksiya chegaralangan yopiq D sohada uzluksiz va $x = x(u, v)$, $y = y(u, v)$ bo'lsin. Bu bog'lanishlardan $u = u(x, y)$ va $v = v(x, y)$ o'zgaruvchilarni yagona usul bilan topish mumkin bo'lsin. Bunda D sohaning Oxy koordinatalar tekisligidagi har bir $P(x, y)$ nuqtasiga \bar{D} sohaning O_1uv koordinatalar tekisligida biror $\bar{P}(u, v)$ nuqta mos keladi.

☞ Agar $x = x(u, v)$ va $y = y(u, v)$ funksiyalar \bar{D} sohada uzluksiz birinchi tartibli xususiy hosilalarga ega bo'lib, shu sohada

$$I = \begin{vmatrix} \frac{\partial x}{\partial u} & \frac{\partial x}{\partial v} \\ \frac{\partial y}{\partial u} & \frac{\partial y}{\partial v} \end{vmatrix} \neq 0 \quad (1.6)$$

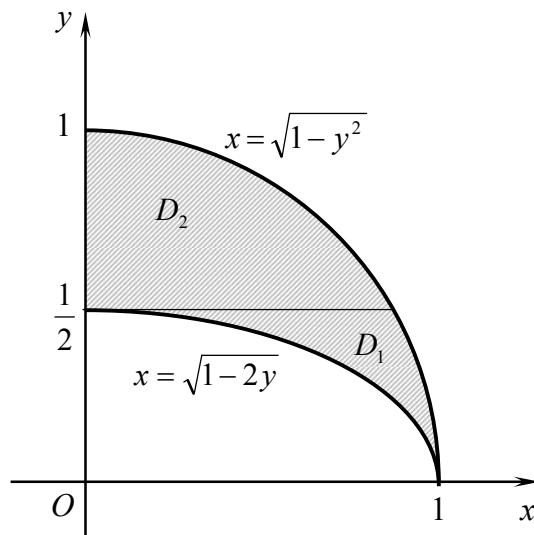

5-shakl.

bo'lsa, u holda ikki karrali integral uchun

$$\iint_D f(x, y) dx dy = \iint_{\bar{D}} f(x(u, v), y(u, v)) |I| du dv \quad (1.7)$$

o'zgaruvchilarni almashtirish formulasi o'rinli bo'ladi.

Xususan, qutb koordinatalari o'zgaruvchini almashtirish formulasi

$$\iint_D f(x, y) dx dy = \iint_{\bar{D}} f(r \cos \varphi, r \sin \varphi) r dr d\varphi \quad (1.8)$$

bo'ladi.

Qutb koordinatalar sistemasida integrallash chegaralari qutbning joylashishiga bog'liq holda aniqlanadi:

1) agar O qutb $\varphi = \alpha$ va $\varphi = \beta$ nurlar orasida joylashgan D sohadan tashqarida yotsa va $\varphi = const$ tenglamali chiziqlar soha chegarasini ikki

nuqtada kesib o'tsa

$$\iint_D f(r \cos \varphi, r \sin \varphi) r dr d\varphi = \int_{\alpha}^{\beta} d\varphi \int_{r_1(\varphi)}^{r_2(\varphi)} f(r \cos \varphi, r \sin \varphi) r dr; \quad (1.9)$$

2) agar qutb D integrallash sohasida yotsa va $\varphi = const$ tenglamali chiziqlar soha chegarasini bitta nuqtada kesib o'tsa

$$\iint_D f(r \cos \varphi, r \sin \varphi) r dr d\varphi = \int_0^{2\pi} d\varphi \int_0^{r(\varphi)} f(r \cos \varphi, r \sin \varphi) r dr; \quad (1.10)$$

3) agar qutb D sohaning chegarasiga tegishli bo'lib, D soha $\varphi = \alpha$ va $\varphi = \beta$ nurlar orasida yotsa

$$\iint_D f(r \cos \varphi, r \sin \varphi) r dr d\varphi = \int_{\alpha}^{\beta} d\varphi \int_0^{r(\varphi)} f(r \cos \varphi, r \sin \varphi) r dr. \quad (1.11)$$

7-misol. $\iint_D y^3 dx dy$ integralni hisoblang, bu yerda $D: y^2 = x, y^2 = 2x, xy = 1$ va $xy = 4$ chiziqlar bilan chegaralangan soha.

☞ $y^2 = ux, xy = v$ deb olamiz. Bundan $x = u^{-\frac{1}{3}} v^{\frac{2}{3}}, y = u^{\frac{1}{3}} v^{\frac{1}{3}}$.

Yakobianni hisoblaymiz:

$$I = \begin{vmatrix} \frac{\partial x}{\partial u} & \frac{\partial x}{\partial v} \\ \frac{\partial y}{\partial u} & \frac{\partial y}{\partial v} \end{vmatrix} = \begin{vmatrix} -\frac{1}{3} u^{-\frac{4}{3}} v^{\frac{2}{3}} & \frac{2}{3} u^{-\frac{1}{3}} v^{-\frac{1}{3}} \\ \frac{1}{3} u^{-\frac{2}{3}} v^{\frac{1}{3}} & \frac{1}{3} u^{\frac{1}{3}} v^{-\frac{2}{3}} \end{vmatrix} = -\frac{1}{3u}, \text{ ya'ni } |I| = \frac{1}{3u}.$$

U holda

$$\iint_D y^3 dx dy = \iint_{\bar{D}} uv \cdot \frac{1}{3u} du dv = \frac{1}{3} \iint_{\bar{D}} v du dv$$

bu yerda $\bar{D} = \{(u; v) \in R^2 : 1 \leq u \leq 2, 1 \leq v \leq 4\}$.

Demak,

$$\frac{1}{3} \iint_{\bar{D}} v du dv = \frac{1}{3} \int_1^2 du \int_1^4 v dv = \frac{1}{3} \int_1^2 \frac{v^2}{2} \Big|_1^4 du = \frac{1}{6} \int_1^2 15 du = \frac{5u}{2} \Big|_1^2 = \frac{5}{2}.$$

8-misol. $\iint \sqrt{x^2 + y^2} dx dy$ integralni hisoblang, bu yerda $D: x^2 + y^2 = x$ va $x^2 + y^2 = 2x$ aylanalar bilan chegaralangan soha.

☞ Integralni qutb koordinatalarida hisoblaymiz. $x^2 + y^2 = x, x^2 + y^2 = 2x$ aylanalar qutb koordinatalarida $r = \cos \varphi, r = 2 \cos \varphi$

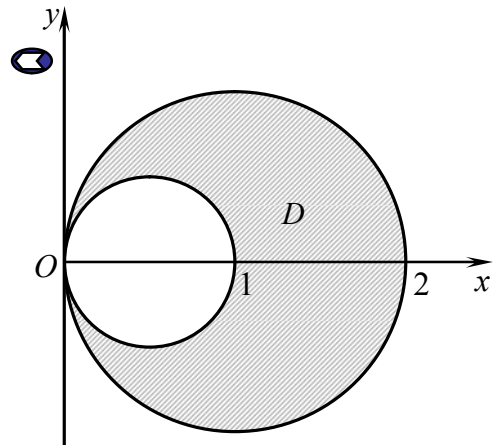

6-shakl.

formular bilan ifodalanadi, bu yerda $-\frac{\pi}{2} \leq \theta \leq \frac{\pi}{2}$ (6-shakl).

U holda

$$\begin{aligned} \iint_D \sqrt{x^2 + y^2} dx dy &= \int_{-\frac{\pi}{2}}^{\frac{\pi}{2}} d\varphi \int_{\cos \varphi}^{2 \cos \varphi} r \cdot r dr = \int_{-\frac{\pi}{2}}^{\frac{\pi}{2}} \frac{r^3}{3} \Big|_{\cos \varphi}^{2 \cos \varphi} d\varphi = \frac{7}{3} \int_{-\frac{\pi}{2}}^{\frac{\pi}{2}} \cos^3 \varphi d\varphi = \frac{7}{3} \int_{-\frac{\pi}{2}}^{\frac{\pi}{2}} \cos^2 \varphi \cos \varphi d\varphi = \\ &= \frac{7}{3} \int_{-\frac{\pi}{2}}^{\frac{\pi}{2}} \cos \varphi d\varphi - \frac{7}{3} \int_{-\frac{\pi}{2}}^{\frac{\pi}{2}} \sin^2 \varphi \cos \varphi d\varphi = \frac{7}{3} \sin \varphi \Big|_{-\frac{\pi}{2}}^{\frac{\pi}{2}} - \frac{7}{9} \sin^3 \varphi \Big|_{-\frac{\pi}{2}}^{\frac{\pi}{2}} = \frac{28}{9}. \end{aligned}$$

2.1.4. Ikki karrali integralning geometrik tatbiqlari

Yassi figuraning yuzasini hisoblash. Oxy tekislik yopiq D sohasining, ya'ni yassi figuraning yuzasi

$$S = \iint_D dx dy \quad (1.12)$$

integral bilan hisoblanadi.

Egri chiziqli sirt yuzasini hisoblash. Oxy tekislikning D sohasida berilgan $z = f(x, y)$ funksiya shu sohada xususiy hosilalari bilan uzluksiz bo'lsin. Bunday funksiya bilan aniqlangan sirt *silliqlik sirt* deyiladi. Bunda D soha bu sirtning Oxy tekislikdagi proyeksiya bo'ladi.

U holda $z = f(x, y)$, $(x, y) \in D$ funksiya bilan aniqlangan sirtning yuzasi

$$S = \iint_D \sqrt{1 + \left(\frac{\partial z}{\partial x}\right)^2 + \left(\frac{\partial z}{\partial y}\right)^2} dx dy \quad (1.13)$$

formula bilan topiladi.

9-misol. $z = 2\sqrt{x^2 + y^2}$ konusning $x^2 + y^2 = 4x$ silindr ichida yotgan sirti yuzasini toping.

7-shaklga ko'ra D soha $(x-2)^2 + y^2 = 4$ doiradan iborat.

Xususiy hosilalarni topamiz:

$$\frac{\partial z}{\partial x} = \frac{2x}{\sqrt{x^2 + y^2}}, \quad \frac{\partial z}{\partial y} = \frac{2y}{\sqrt{x^2 + y^2}}.$$

Demak,

$$S = \iint_D \sqrt{1 + \frac{4x^2}{x^2 + y^2} + \frac{4y^2}{x^2 + y^2}} dx dy =$$

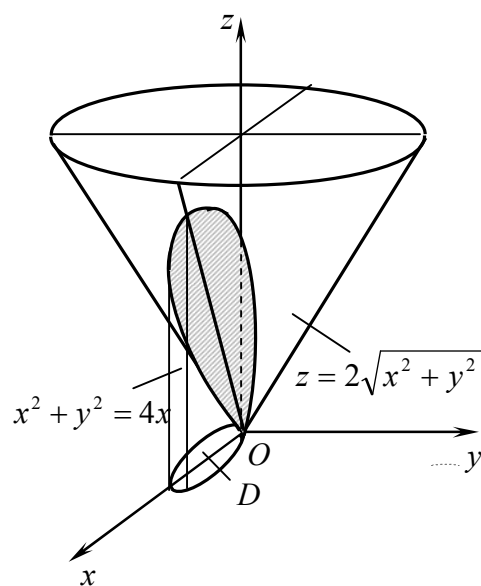

7-shakl.

$$\begin{aligned}
&= \sqrt{5} \iint_D dx dy \left| \begin{array}{l} x = r \cos \varphi, \quad y = r \sin \varphi \\ 0 \leq \varphi \leq \pi, \quad 0 \leq r \leq 4 \sin \varphi \end{array} \right| = \\
&= \sqrt{5} \int_0^\pi d\varphi \int_0^{4 \cos \varphi} r dr = \sqrt{5} \int_0^\pi \frac{r^2}{2} \Big|_0^{4 \cos \varphi} = 8\sqrt{5} \int_0^\pi \cos^2 \varphi d\varphi = 4\sqrt{5} \int_0^\pi (1 + \cos 2\varphi) d\varphi = \\
&4\sqrt{5} \left(\varphi + \frac{1}{2} \sin 2\varphi \right) \Big|_0^\pi = 4\pi\sqrt{5}. \quad \bullet
\end{aligned}$$

Jism hajmini hisoblash. Yuqoridan $z = f(x, y)$ sirt bilan, quyidan Oxy tekislikning yopiq D sohasi bilan, yon tomonlaridan yasovchilari Oz o'qqa parallel bo'lgan silindrik sirt bilan chegaralangan jism *silindrik jism* deyiladi. Bu silindrik jismning hajmi

$$V = \iint_D f(x, y) dx dy \quad (1.14)$$

integralga teng bo'ladi (ikki karrali integralning *geometrik ma'nosi*).

10-misol. Ushbu $\frac{x^2}{a^2} + \frac{y^2}{b^2} + \frac{z^2}{c^2} \leq 1$ ellipsoidning hajmini toping.

☞ $z \geq 0$ da ellipsoid hajmini V_1 deylik.

U holda

$$V = 2V_1 = 2c \iint_D \sqrt{1 - \frac{x^2}{a^2} - \frac{y^2}{b^2}} dx dy,$$

bu yerda $D - \frac{x^2}{a^2} + \frac{y^2}{b^2} = 1$ ellips bilan chegaralangan soha.

$x = a \cos \varphi$, $y = b \sin \varphi$ umumlashgan qutb koordinatalariga o'tamiz. Bunda D soha $\bar{D} = \{(r; \varphi) : 0 \leq r \leq 1, 0 \leq \varphi \leq 2\pi\}$ to'g'ri to'rtburchakka akslanadi.

Bundan

$$I = \begin{vmatrix} \frac{\partial x}{\partial r} & \frac{\partial x}{\partial \varphi} \\ \frac{\partial y}{\partial r} & \frac{\partial y}{\partial \varphi} \end{vmatrix} = \begin{vmatrix} a \cos \varphi & -a r \sin \varphi \\ b \sin \varphi & b r \cos \varphi \end{vmatrix} = abr.$$

Demak,

$$\begin{aligned}
V &= 2c \int_0^1 dr \int_0^{2\pi} \sqrt{1 - r^2} abr d\varphi = 2abc \int_0^1 r \sqrt{1 - r^2} \Big|_0^{2\pi} dr = \\
&= 4abc \pi \int_0^1 r \sqrt{1 - r^2} dr \Big|_{t = \sqrt{1 - r^2}} = 4\pi abc \int_0^1 t^2 dt = 4\pi abc \frac{t^3}{3} \Big|_0^1 = \frac{4\pi}{3} abc. \quad \bullet
\end{aligned}$$

Ikki karrali integralning mexanik tatbiqlari

Oxy tekislikda sirtiy zichligi $\gamma(x, y)$ ga teng bo'lgan bir jinsli D plastinka berilgan bo'lsin. Bu plastinkaning ba'zi mexanik parametrlari ikki karrali integralning mexanik ma'nosiga ko'ra quyidagi formulalar bilan aniqlanadi:

1) *plastinkaning massasi* (ikki karrali integralning *mexanik ma'nosi*)

$$m = \iint_D \gamma(x, y) dx dy; \quad (1.15)$$

2) *plastinkaning koordinata o'qlariga nisbatan statik momentlari*

$$M_x = \iint_D y\gamma(x, y) dx dy, \quad M_y = \iint_D x\gamma(x, y) dx dy; \quad (1.16)$$

3) *plastinka og'irlik markazining koordinatalari*

$$x_c = \frac{\iint_D x\gamma(x, y) dx dy}{\iint_D \gamma(x, y) dx dy}, \quad y_c = \frac{\iint_D y\gamma(x, y) dx dy}{\iint_D \rho(x, y) dx dy}; \quad (1.17)$$

4) *plastinkaning koordinatalar boshiga va koordinata o'qlariga nisbatan inertsia momentlari*

$$I_0 = \iint_D (x^2 + y^2)\gamma(x, y) dx dy, \quad I_x = \iint_D y^2\gamma(x, y) dx dy, \quad I_y = \iint_D x^2\gamma(x, y) dx dy. \quad (1.18)$$

11-misol. Zichligi $\gamma = x + y$ ga teng D plastinka og'irlik markazining koordinatalarini toping, bu yerda $D: x=0, x=2, y=0, y=2$ chiziqlar bilan chegaralangan kvadrat.

☞ Avval plastinkaning massasini topamiz:

$$\begin{aligned} m &= \iint_D \gamma(x, y) dx dy = \int_0^2 dx \int_0^2 (x + y) dy = \int_0^2 \left(xy + \frac{y^2}{2} \right) \Big|_0^2 dx = \\ &= \int_0^2 (2x + 2) dx = (x^2 + 2x) \Big|_0^2 = 8. \end{aligned}$$

Plastinka og'irlik markazining koordinatalarini aniqlaymiz:

$$\begin{aligned} x_c &= \frac{1}{8} \iint_D x\gamma(x, y) dx dy = \frac{1}{8} \int_0^2 dx \int_0^2 (x^2 + xy) dy = \frac{1}{8} \int_0^2 \left(x^2 y + x \cdot \frac{y^2}{2} \right) \Big|_0^2 dx = \\ &= \frac{1}{4} \int_0^2 (x^2 + x) dx = \frac{1}{4} \left(\frac{x^3}{3} + \frac{x^2}{2} \right) \Big|_0^2 = \frac{7}{6}; \end{aligned}$$

$$\begin{aligned} y_c &= \frac{1}{8} \iint_D y\gamma(x, y) dx dy = \frac{1}{8} \int_0^2 dy \int_0^2 (y^2 + xy) dx = \frac{1}{8} \int_0^2 \left(y^2 x + y \cdot \frac{x^2}{2} \right) \Big|_0^2 dy = \\ &= \frac{1}{4} \int_0^2 (y^2 + y) dy = \frac{1}{4} \left(\frac{y^3}{3} + \frac{y^2}{2} \right) \Big|_0^2 = \frac{7}{6}. \quad \bullet \end{aligned}$$

Mashqlar

2.1.1. Integrallarni baholang:

- 1) $\iint_D (x^2 + 3y^2 + 2)ds$, bu yerda $D: x^2 + y^2 = 4$ aylana bilan chegaralangan doira;
- 2) $\iint_D (x^2 + xy + 2y^2)ds$, bu yerda $D: x=0, y=0$ va $x+y=1$ chiziqlar bilan chegaralangan uchburchak;
- 3) $\iint_D (x + xy - x^2 - y^2)ds$, bu yerda $D: x=0, x=1, y=0$ va $y=2$ chiziqlar bilan chegaralangan to'g'ri to'rtburchak;
- 4) $\iint_D (2 + y)^x ds$, bu yerda $D: x=0, x=2, y=0$ va $y=2$ chiziqlar bilan chegaralangan kvadrat.

2.1.2. Integrallarda integrallash tartibini o'zgartiring:

$$1) \int_0^1 dy \int_{\frac{y^2}{9}}^y f(x, y) dx + \int_1^3 dy \int_{\frac{y^2}{9}}^1 f(x, y) dx; \quad 2) \int_0^3 dx \int_0^{\frac{4x^2}{9}} f(x, y) dy + \int_3^5 dx \int_0^{\sqrt{25-x^2}} f(x, y) dy;$$
$$3) \int_{-6}^2 dy \int_{\frac{y^2}{4}-1}^{2-y} f(x, y) dx; \quad 4) \int_0^3 dx \int_{\sqrt{9-x^2}}^{\sqrt{25-x^2}} f(x, y) dy.$$

2.1.3. Ikki karrali integrallarni hisoblang:

$$1) \iint_{0,0}^{1,2} xy(x+y) dx dy; \quad 2) \iint_{0,x^2}^{1,x} xy^2 dx dy;$$
$$3) \iint_{1,1}^{e,y} \frac{y}{x} dx dy; \quad 4) \int_{-2}^{-1} \int_1^{3+x} \frac{\ln y}{y(x+3)} dx dy.$$

2.1.4. Berilgan chiziqlar bilan chegaralangan D sohada ikki karrali integrallarni hisoblang:

- 1) $\iint_D (x^2 + y^2) dx dy$, $D: x=0, x=1, y=0, y=x^2$;
- 2) $\iint_D (x + 2y) dx dy$, $D: y=x^2, y=5x-6$;
- 3) $\iint_D e^{x+\cos y} \sin y dx dy$, $D: x=0, x=\pi, y=0, y=\frac{\pi}{2}$;
- 4) $\iint_D x \sin(x+y) dx dy$, $D: x=0, x=\pi, y=0, y=\frac{\pi}{2}$;
- 5) $\iint_D (\sin x + \cos 2y) dx dy$, $D: x=0, y=0, 4x+4y=\pi$;

- 6) $\iint_D \frac{x^2}{y^2} dx dy$, $D: xy=1, y=x, x=2$;
- 7) $\iint_D \frac{y}{x^2 + y^2} dx dy$, $D: y=0, y=2, x=y, x=y\sqrt{3}$;
- 8) $\iint_D e^x y dx dy$, $D: x=0, x=2, y=1, y=e^x$;
- 9) $\iint_D y dx dy$, $D: x = a \cos^3 t, y = a \sin^3 t \left(0 \leq t \leq \frac{\pi}{2} \right)$;
- 10) $\iint_D x^2 y dx dy$, $D: x = a \cos t, y = b \sin t \left(0 \leq t \leq \frac{\pi}{2} \right)$;
- 11) $\iint_D (x+y)^3 (x-y)^2 dx dy$, $D: x+y=1, x+y=3, x-y=-1, x-y=1$;
- 12) $\iint_D xy dx dy$, $D: xy=1, xy=3, y=2x, y=4x$;
- 13) $\iint_D \sqrt{x^2 + y^2} dx dy$, $D: x^2 + y^2 = 9$;
- 14) $\iint_D \sqrt{9 + 4x^2 + 4y^2} dx dy$, $D: x^2 + y^2 = 4$;
- 15) $\iint_D \frac{dx dy}{x^2 + y^2 + 2}$, $D: y = \sqrt{4 - x^2}, y = 0$;
- 16) $\iint_D \sqrt{x^2 + y^2 - 16} dx dy$, $D: x^2 + y^2 = 16, x^2 + y^2 = 25$;
- 17) $\iint_D \sqrt{4 - x^2 - y^2} dx dy$, $D: x^2 + y^2 = 2x$;
- 18) $\iint_D \frac{\sin \sqrt{x^2 + y^2}}{\sqrt{x^2 + y^2}} dx dy$, $D: x^2 + y^2 = \frac{\pi^2}{9}, x^2 + y^2 = \pi^2$;
- 19) $\iint_D xy dx dy$, $D: \frac{x^2}{16} + \frac{y^2}{9} = 1, x=0, y=0$;
- 20) $\iint_D x dx dy$, $D: x^2 + y^2 = 2y, x^2 + y^2 = 4y, y=x, x=0$.

2.1.5. Berilgan chiziqlar bilan chegaralangan soha yuzasini hisoblang:

- | | |
|---|---|
| 1) $y = x, y = 2 - x^2$; | 2) $y = \frac{b}{a}x, y^2 = \frac{b^2}{a}x$; |
| 3) $y = \frac{8}{x^2 + 4}, x^2 = 4y$; | 4) $xy = 6, x + y = 5$; |
| 5) $x^2 + y^2 = 4x, x^2 + y^2 = 8x, y = x, y = 0$; | 6) $(x^2 + y^2)^2 = 4(x^2 - y^2)$. |
| 7) $xy = 1, xy = 4, x = y, x = 9y$; | 8) $x^{\frac{2}{3}} + y^{\frac{2}{3}} = 4$. |

2.1.6. σ sirt yuzasini hisoblang:

- 1) $\sigma: z = x^2 + y^2$ paraboloidning $z = 0$ va $z = 2$ tekisliklar orasidagi qismi;
- 2) $\sigma: 2y = x^2 + z^2$ paraboloidning $x^2 + z^2 = 4$ silindr orasidagi qismi;
- 3) $\sigma: z = \sqrt{x^2 + y^2}$ konusning $z = 2$ tekislik bilan kesilgan qismi;
- 4) $\sigma: x + y + z = 3$ tekislikning $y^2 = 3x$ silindr va $x = 3$ tekislik bilan kesilgan qismi.

2.1.7. Berilgan sirtlar bilan chegaralangan jism hajmini hisoblang:

- 1) $x + y + z = a, x = 0, y = 0, z = 0$;
- 2) $z = \frac{4}{x^2 + y^2}, z = 0, x^2 + y^2 = 1, x^2 + y^2 = 4$;
- 3) $z = 4 - y^2, z = y^2 + 2, x = -1, x = 2$;
- 4) $z = x^2 + y^2, z = 0, y = x^2, y = 1$;
- 5) $z = x^2 + y^2, z = 2x^2 + 2y^2, y = x^2, y = x$.
- 6) $y = 1 + x^2 + z^2, y = 5$;
- 7) $z = 4 - y^2, z = 0, y = \frac{x^2}{2}$;
- 8) $x + z = 4, z = 0, y = \sqrt{x}, y = 2\sqrt{x}$;
- 9) $z = xy, xy = 1, xy = 2, y = x, y = 3x$;
- 10) $x^2 + y^2 = 9, x^2 + z^2 = 9$.

2.1.8. Sirtiy zichligi γ ga teng bo'lgan va berilgan chiziqlar bilan chegaralangan yassi plastinkaning massasini toping:

- 1) $\gamma = y, y = x - 1, x = (y - 1)^2$;
- 2) $\gamma = x^2, y = 0, y = 2x, x + y = 6$.

2.1.9. $y^2 = ax, y = x$ chiziqlar bilan chegaralangan bir jinsli yassi plastinka og'irlik markazining koordinatlarini toping.

2.1.10. Katetlari $OA = a$ va $OB = b$ ga teng bo'lgan to'g'ri burchakli uchburchakdan iborat yassi plastinkaning sirtiy zichligi OB masofaga proporsional bo'lsa, plastinka og'irlik markazining koordinatlarini toping.

2.1.11. $y = 4 - x^2, y = 0$ chiziqlar bilan chegaralangan bir jinsli yassi plastinkaning Oy o'qqa nisbatan inersiya momentini toping.

2.1.12. Uchlari $A(0;4), B(2;0), C(2;2)$ nuqtalarda joylashgan uchburchakdan iborat bir jinsli yassi plastinkaning Oy o'qqa nisbatan inersiya momentini toping.

2.2. UCH KARRALI INTEGRAL

Uch karrali integral. Uch karrali integralni hisoblash. Uch karrali integralning tatbiqlari

2.2.1. *Oxyz* fazoning yopiq V sohasida (hajmi V ga teng jismida) $t = f(x, y, z)$ funksiya aniqlangan va uzluksiz bo'lsin.

V sohani ixtiyoriy ravishda umumiy ichki nuqtalarga ega bo'lmagan va hajmlari ΔV_i ga teng bo'lgan n ta $V_i (i = \overline{1, n})$ elementar sohalarga bo'lamiz. Har bir V_i sohada ixtiyoriy $P(x_i; y_i; z_i)$ nuqtani tanlaymiz, $f(x, y, z)$ funksiyaning bu nuqtadagi qiymati $f(x_i, y_i, z_i)$ ni hisoblab, uni ΔV_i ga ko'paytiramiz va barcha bunday ko'paytmalarning yig'indisini tuzamiz:

$$I_n = \sum_{i=1}^n f(x_i, y_i, z_i) \Delta V_i. \quad (2.1)$$

Bu yig'indiga $f(x, y, z)$ funksiyaning V sohadagi integral yig'indisi deyiladi.

V_i soha chegaraviy nuqtalari orasidagi masofalarning eng kattasiga shu sohaning diametri deyiladi va d_i bilan belgilanadi, bunda $n \rightarrow \infty$ da $d_i \rightarrow 0$.

Agar (2.1) integral yig'indining $\max d_i \rightarrow 0$ dagi chekli limiti V sohani bo'laklarga bo'lish usuliga va bu bo'laklarda $P(x_i; y_i; z_i)$ nuqtani tanlash usuliga bog'liq bo'lmagan holda mavjud bo'lsa, bu limitga $f(x, y, z)$ funksiya V soha bo'yicha olingan uch karrali integral deyiladi va $\iiint_V f(x, y, z) dV$ bilan belgilanadi:

$$\iiint_V f(x, y, z) dV = \lim_{\max d_i \rightarrow 0} \sum_{i=1}^n f(x_i, y_i, z_i) \Delta V_i \quad (2.2)$$

yoki

$$\iiint_V f(x, y, z) dx dy dz = \lim_{\max d_i \rightarrow 0} \sum_{i=1}^n f(x_i, y_i, z_i) \Delta x_i \Delta y_i \Delta z_i. \quad (2.3)$$

1-teorema (*funksiya integrallanuvchi bo'lishining etarli sharti*). Agar $t = f(x, y, z)$ funksiya chegaralangan yopiq V sohada uzluksiz bo'lsa, u holda u shu sohada integrallanuvchi bo'ladi.

Uch karrali integral ikki karrali integralning barcha xossalriga ega.

2.2.2. Uch karrali integralni dekart koordinatalarida hisoblash

V integrallash sohasi quyidan $z = z_1(x, y)$ sirt bilan, yuqoridan $z = z_2(x, y)$ sirt bilan chegaralangan jismdan iborat va Oz o'q yo'nalishi bo'yicha

muntazam bo'lsin, bu yerda $z = z_1(x, y)$, $z = z_2(x, y)$ – V jismning Oxy tekislikdagi proyeksiyasi D da uzluksiz funksiyalar.

Agar D soha $x = a$, $x = b$ ($a < b$), $y = \varphi_1(x)$ va $y = \varphi_2(x)$ ($\varphi_1(x) \leq \varphi_2(x)$) chiziqlar bilan (bunda $\varphi_1(x)$, $\varphi_2(x)$ – $[a; b]$ kesmada uzluksiz funksiyalar) chegaralangan egri chiziqli trapetsiya bo'lsa

$$\iiint_V f(x, y, z) dx dy dz = \int_a^b dx \int_{\varphi_1(x)}^{\varphi_2(x)} dy \int_{z_1(x, y)}^{z_2(x, y)} f(x, y, z) dz \quad (2.4)$$

bo'ladi.

1-misol. Uch karrali integrallarni hisoblang:

$$1) \int_0^1 dx \int_1^2 dy \int_2^3 x^3 y^2 z dz;$$

$$2) \int_0^1 dx \int_0^x dy \int_0^y xyz dz.$$

☉ 1) Integrallash chegaralari o'zgarmas bo'lgani sababli bu integral uchta aniq integralning ko'paytmasidan iborat bo'ladi:

$$\int_0^1 dx \int_1^2 dy \int_2^3 x^3 y^2 z dz = \int_0^1 x^3 dx \cdot \int_1^2 y^2 dy \cdot \int_2^3 z dz = \frac{x^4}{4} \Big|_0^1 \cdot \frac{y^3}{3} \Big|_1^2 \cdot \frac{z^2}{2} \Big|_2^3 = \frac{1-0}{4} \cdot \frac{8-1}{3} \cdot \frac{9-4}{2} = \frac{35}{24}.$$

2) Ichki integralni x va y o'zgarmas deb z bo'yicha hisoblaymiz:

$$\int_0^1 dx \int_0^x dy \int_0^y xyz dz = \int_0^1 dx \int_0^x xy \frac{z^2}{2} \Big|_0^y dy = \frac{1}{2} \int_0^1 dx \int_0^x xy^3 dy.$$

Shunday qilib, uch karrali integral ikki karrali integralga keltirildi.

Uni hisoblaymiz:

$$\frac{1}{2} \int_0^1 x \frac{y^4}{4} \Big|_0^x dx = \frac{1}{8} \int_0^1 x^5 dx = \frac{1}{8} \cdot \frac{x^6}{6} \Big|_0^1 = \frac{1}{48}. \quad \text{☉}$$

2-misol. $\iiint_V z dx dy dz$ integralni hisoblang, bu yerda $V: x=0, y=0, z=0,$

$x+y+z=1$ sirtlar bilan chegaralangan soha.

☉ Berilgan sirtlar bo'yicha integrallash sohasini chizamiz (8-shakl).

V soha uchun: $0 \leq x \leq 1, 0 \leq y \leq 1-x, 0 \leq z \leq 1-x-y.$

Bundan

$$\begin{aligned} \iiint_V z dx dy dz &= \int_0^1 dx \int_0^{1-x} dy \int_0^{1-x-y} z dz = \int_0^1 dx \int_0^{1-x} \frac{z^2}{2} \Big|_0^{1-x-y} dy = \frac{1}{2} \int_0^1 dx \int_0^{1-x} (1-x-y)^2 dy = \\ &= -\frac{1}{2} \int_0^1 \frac{(1-x-y)^3}{3} \Big|_0^{1-x} dx = \frac{1}{6} \int_0^{1-x} (1-x)^3 dx = -\frac{1}{6} \cdot \frac{(1-x)^4}{4} \Big|_0^1 = \frac{1}{24}. \quad \text{☉} \end{aligned}$$

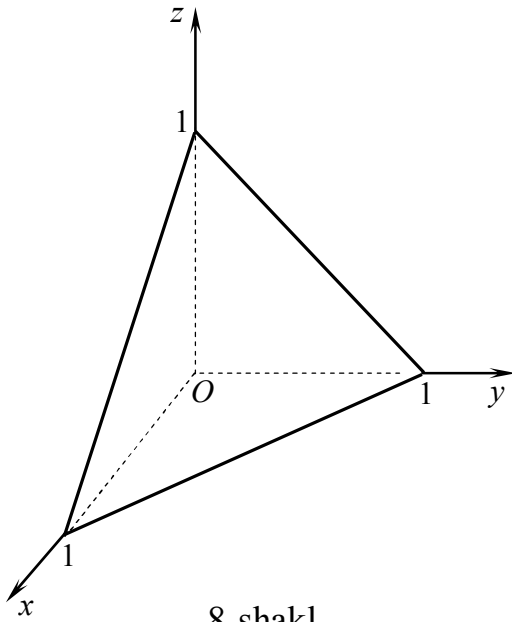

8-shakl.

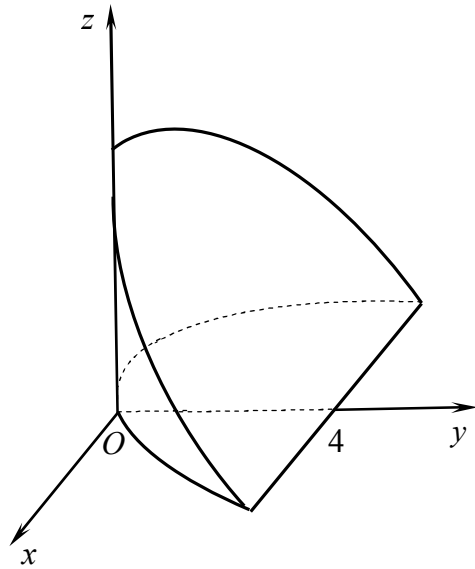

9-shakl.

3-misol. $\iiint_V (x+2y) dx dy dz$ integralni hisoblang, bu yerda

$V: y = x^2, y + z = 4, z = 0$ sirtlar bilan chegaralangan soha.

☉ Berilgan sirtlar bo'yicha integrallash sohasini chizamiz (9-shakl).

V soha uchun:

$$-2 \leq x \leq 2, x^2 \leq y \leq 4, 0 \leq z \leq 4 - y.$$

Bundan

$$\begin{aligned} \iiint_V z dx dy dz &= \int_0^1 dx \int_0^{1-x} dy \int_1^{1-x-y} z dz = \int_0^1 dx \int_0^{1-x} \frac{z^2}{2} \Big|_0^{1-x-y} dy = \\ &= \frac{1}{2} \int_0^1 dx \int_0^{1-x} (1-x-y)^2 dy = \\ &= -\frac{1}{2} \int_0^1 \frac{(1-x-y)^3}{3} dx = \frac{1}{6} \int_0^{1-x} (1-x)^3 dx = \\ &= -\frac{1}{6} \cdot \frac{(1-x)^4}{4} \Big|_0^1 = \frac{1}{24}. \quad \text{☉} \end{aligned}$$

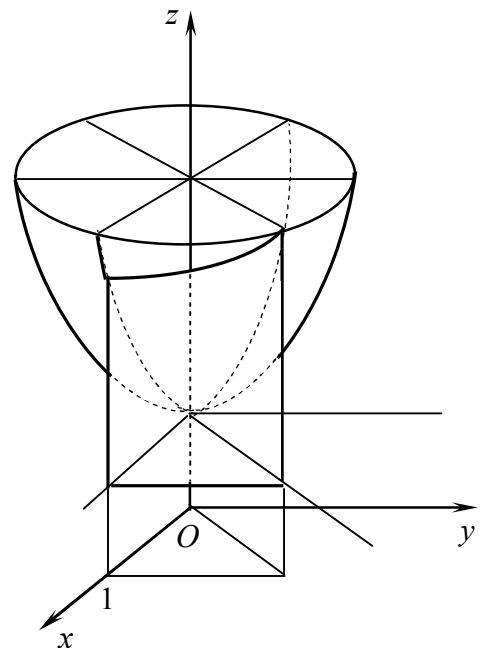

10-shakl.

4-misol. $\iiint_V (2x+y) dx dy dz$ integralni hisoblang, bunda

$V: y = x, y = 0, x = 1, z = 1, z = 1 + x^2 + y^2$ sirtlar bilan chegaralangan soha.

☉ Berilgan sirtlar bo'yicha integrallash sohasini chizamiz (10-shakl).

V soha uchun: $0 \leq x \leq 1$, $0 \leq y \leq x$, $1 \leq z \leq 1 + x^2 + y^2$. Bundan

$$\begin{aligned} \iiint_V (2x + y) dx dy dz &= \int_0^1 dx \int_0^x dy \int_1^{1+x^2+y^2} (2x + y) dz = \\ &= \int_0^1 dx \int_0^x (2x + y) z \Big|_1^{1+x^2+y^2} dy = \int_0^1 dx \int_0^x (2x + y)(x^2 + y^2) dy = \\ &= \int_0^1 \left(2x^3 y + \frac{1}{2} x^2 y^2 + \frac{2}{3} x y^3 + \frac{1}{4} y^4 \right) \Big|_0^x dx = \\ &= \int_0^1 \left(2 + \frac{1}{2} + \frac{2}{3} + \frac{1}{4} \right) x^4 dx = \frac{41}{12} \cdot \frac{x^5}{5} \Big|_0^1 = \frac{41}{60}. \quad \bullet \end{aligned}$$

Uch karrali integralda o'zgaruvchini almashtirish

V sohada $x = x(u, v, w)$, $y = y(u, v, w)$, $z = z(u, v, w)$ o'rniga qo'yish bajarilgan bo'lsin. U holda $Oxyz$ koordinatalar tekisligidagi V soha O_{1uvw} koordinatalar tekisligida biror yopiq \bar{V} sohaga akslanadi.

⇒ Agar $x = x(u, v, w)$, $y = y(u, v, w)$, $z = z(u, v, w)$ funksiyalar \bar{V} sohada uzluksiz birinchi tartibli xususiy hosilalarga ega bo'lib, shu sohada

$$I = \begin{vmatrix} \frac{\partial x}{\partial u} & \frac{\partial x}{\partial v} & \frac{\partial x}{\partial w} \\ \frac{\partial y}{\partial u} & \frac{\partial y}{\partial v} & \frac{\partial y}{\partial w} \\ \frac{\partial z}{\partial u} & \frac{\partial z}{\partial v} & \frac{\partial z}{\partial w} \end{vmatrix} \neq 0 \quad (2.5)$$

bo'lsa, u holda uch karrali integral uchun

$$\iiint_V f(x, y, z) dx dy dz = \iiint_{\bar{V}} f(x(u, v, w), y(u, v, w), z(u, v, w)) |I| du dv dw \quad (2.6)$$

o'zgaruvchilarni almashtirish formulasi o'rinli bo'ladi.

Uch karrali integralni silindrik koordinatalarida hisoblash

r, φ, z sonlar uchligiga $Oxyz$ fazo $M(x; y; z)$ nuqtasining *silindrik koordinatalari* deyiladi, bu yerda r – M nuqtaning Oxy tekislikka proeksiyasi radius vektorining uzunligi, φ – bu radius vektorning Ox oq bilan tashkil qilgan burchagi, z – M nuqtaning applikatasi.

Silindrik koordinatalar dekart koordinatalari bilan

$$x = r \cos \varphi, \quad y = r \sin \varphi, \quad z = z$$

bog'lanishga ega, bu yerda $0 \leq \varphi \leq 2\pi$, $0 \leq r \leq +\infty$, $-\infty < z < +\infty$.

Uch karrali integral silindrik koordinatalarida

$$\iiint_V f(x, y, z) dx dy dz = \iiint_V f(r \cos \varphi, r \sin \varphi, z) r d\varphi dr dz \quad (2.7)$$

o'zgaruvchilarni almashtirish formulasi orqali hisoblanadi.

5-misol. $\iiint_V \sqrt{x^2 + y^2} dx dy dz$ integralni

hisoblang, bunda

$$V: x^2 + y^2 = 4, z = 1, z = 2 + x^2 + y^2$$

sirtlar bilan chegaralangan soha.

☉ Berilgan sirtlar bo'yicha V sohani chizamiz (11-shakl).

Integralni silindrik koordinatalarda hisoblaymiz:

$$\begin{aligned} \iiint_V \sqrt{x^2 + y^2} dx dy dz &= \iiint_V r \cdot r d\varphi dr dz = \int_0^{2\pi} d\varphi \int_0^2 dr \int_1^{2+r^2} r^2 dz = \\ &= \int_0^{2\pi} d\varphi \int_0^2 r^2 z \Big|_1^{2+r^2} dr = \frac{136}{15} \int_0^{2\pi} d\varphi = \frac{136}{15} \varphi \Big|_0^{2\pi} = \frac{272}{15} \pi. \end{aligned}$$

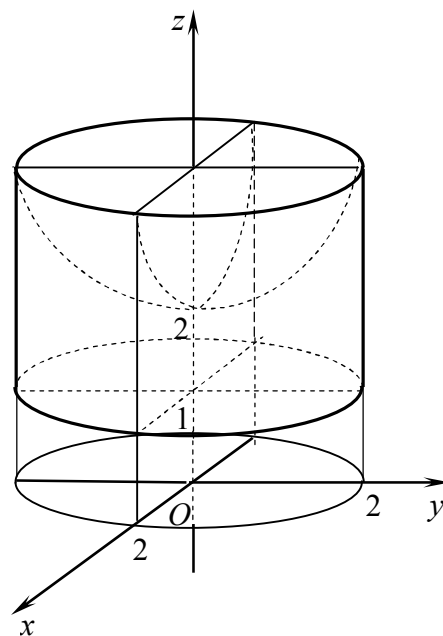

11-shakl.

Uch karrali integralni sferik koordinatalarida hisoblash

r, φ, θ sonlar uchligiga $Oxyz$ fazo $M(x; y; z)$ nuqtasining sferik koordinatalari deyiladi, bu yerda r – M nuqta radius vektorining uzunligi, φ – \overline{OM} radius vektorning Oxy tekislikka proeksiyasining Ox oq bilan tashkil qilgan burchagi, θ – \overline{OM} radius vektorning Oz o'qdan og'ish burchagi.

Sferik koordinatalar dekart koordinatalari bilan

$$x = r \cos \varphi \sin \theta, y = r \sin \varphi \sin \theta, z = r \cos \theta,$$

bog'lanishga ega, bu yerda $0 \leq \varphi \leq 2\pi, 0 \leq r \leq +\infty, 0 < \theta < \pi$.

Uch karrali integral sferik koordinatalarida

$$\iiint_V f(x, y, z) dx dy dz = \iiint_V f(r \cos \varphi \sin \theta, r \sin \varphi \sin \theta, r \cos \theta) r^2 \sin \theta d\varphi dr d\theta \quad (2.8)$$

o'zgaruvchilarni almashtirish formulasi bilan hisoblanadi.

6-misol. $\iiint_V \sqrt{x^2 + y^2 + z^2} dx dy dz$ integralni hisoblang, bu yerda

$V: x^2 + y^2 + z^2 = 4, y = 0 (y \geq 0)$ sirtlar bilan chegaralangan soha.

☉ V integrallash sohasi Oxz tekislikning o'ng tomonda joylashgan yarim shardan iborat. Shu sababli integralni sferik koordinatalarda

hisoblaymiz, bunda $0 \leq r \leq 2$, $0 \leq \varphi \leq \pi$, $0 \leq \theta \leq \pi$:

$$\begin{aligned} \iiint_V \sqrt{x^2 + y^2 + z^2} dx dy dz &= \iiint_V r \cdot r^2 \sin \theta dr d\varphi d\theta = \int_0^\pi d\varphi \int_0^\pi d\theta \int_0^2 r^3 \sin \theta dr = \\ &= \int_0^\pi d\varphi \int_0^\pi \sin \theta \frac{r^4}{4} \Big|_0^2 d\theta = \int_0^\pi d\varphi \int_0^\pi 4 \sin \theta d\theta = -4 \int_0^\pi \cos \theta \Big|_0^\pi d\varphi = 8 \int_0^\pi d\varphi = 8\varphi \Big|_0^\pi = 8\pi. \end{aligned}$$

2.2.3. V jismning hajmi

$$V = \iiint_V dx dy dz \quad (2.9)$$

integral bilan topiladi (uch karrali integralning *geometrik* ma'nosi).

7-misol. $(x^2 + y^2 + z^2)^2 = a^3 x$ sirt bilan chegaralangan jism hajmini hisoblang.

☞ Sirt tenglamasi $x^2 + y^2 + z^2$ ifodani o'z ichiga olgani sababli tenglamani sferik koordinatalarda yozib olamiz:

$$r = a \sqrt[3]{\sin \theta \cos \varphi}.$$

y va z o'zgaruvchilar sirt tenglamasiga kvadratlari bilan qatnashadi. Shu sababli jism Oxz va Oxy tekisliklarga nisbatan simmetrik bo'ladi. $x \geq 0$ bo'lgani uchun jism hajmining chorak qismini hisoblash yetarli. Birinchi oktantda $0 \leq \theta \leq \frac{\pi}{2}$, $0 \leq \varphi \leq \frac{\pi}{2}$ bo'ladi. Bundan

$$\begin{aligned} V &= 4 \int_0^{\frac{\pi}{2}} d\theta \int_0^{\frac{\pi}{2}} d\varphi \int_0^{a \sqrt[3]{\sin \theta \cos \varphi}} r^2 \sin \theta dr = \frac{4a^3}{3} \int_0^{\frac{\pi}{2}} \sin^2 \theta d\theta \int_0^{\frac{\pi}{2}} \cos \varphi d\varphi = \\ &= \frac{2a^3}{3} \int_0^{\frac{\pi}{2}} (1 - \cos 2\theta) \sin \varphi \Big|_0^{\frac{\pi}{2}} d\theta = \frac{2a^3}{3} \left(\theta - \frac{\sin 2\theta}{2} \right) \Big|_0^{\frac{\pi}{2}} = \frac{\pi a^3}{3}. \end{aligned}$$

Zichligi $\gamma(x, y, z)$ ga teng bo'lgan V jismning ba'zi mexanik parametrlari uch karrali integral yordamida quyidagi formulalar bilan hisoblanadi:

1) *jismning massasi* (uch karrali integralning *mexanik* ma'nosi):

$$m = \iiint_D \gamma(x, y, z) dx dy dz;$$

2) *jismning* Oyz , Oxz va Oxy tekisliklarga nisbatan *statik momentlari*:

$$M_{yz} = \iiint_V x\gamma(x, y, z) dx dy dz, \quad M_{xz} = \iiint_V y\gamma(x, y, z) dx dy dz, \quad M_{xy} = \iiint_V z\gamma(x, y, z) dx dy dz;$$

3) *jism og'irlik markazining koordinatalari*:

$$x_c = \frac{\iiint_V x\gamma(x, y, z) dx dy dz}{\iiint_V \gamma(x, y, z) dx dy dz}, \quad y_c = \frac{\iiint_V y\gamma(x, y, z) dx dy dz}{\iiint_V \gamma(x, y, z) dx dy dz}, \quad z_c = \frac{\iiint_V z\gamma(x, y, z) dx dy dz}{\iiint_V \gamma(x, y, z) dx dy dz};$$

4) jismning koordinatalar boshiga, Ox, Oy, Oz o'qlarga va Oyz, Oxz, Oxy tekisliklarga nisbatan *inersiya momentlari*

$$I_0 = \iiint_V (x^2 + y^2 + z^2) \gamma(x, y, z) dx dy dz, \quad I_x = \iiint_V (y^2 + z^2) \gamma(x, y, z) dx dy dz,$$

$$I_y = \iiint_V (x^2 + z^2) \gamma(x, y, z) dx dy dz, \quad I_z = \iiint_V (x^2 + y^2) \gamma(x, y, z) dx dy dz,$$

$$I_{xy} = \iiint_V z^2 \gamma(x, y, z) dx dy dz, \quad I_{yz} = \iiint_V x^2 \gamma(x, y, z) dx dy dz, \quad I_{xz} = \iiint_V y^2 \gamma(x, y, z) dx dy dz.$$

8-misol. $x^2 + y^2 + z^2 = R^2, z \geq 0$ yarim sharning har bir nuqtadagi zichligi nuqtadan shar markazigacha bo'lgan masofaga proporsional bo'lsa, shar og'irlik markazining koordinatalarini toping.

☞ Masala shartiga ko'ra $\gamma = k\sqrt{x^2 + y^2 + z^2}$ va simmetriyaga binoan $x_c = y_c = 0$.

Hisoblashlarni sferik koordinatalarda bajaramiz:

$$m = k \iiint_V \sqrt{x^2 + y^2 + z^2} dx dy dz = k \iiint_V r^3 \sin \theta dr d\varphi d\theta =$$

$$= k \int_0^{2\pi} d\varphi \int_0^{\frac{\pi}{2}} \sin \theta d\theta \int_0^R r^3 dr = -k \varphi \Big|_0^{2\pi} \cdot \cos \theta \Big|_0^{\frac{\pi}{2}} \cdot \frac{r^4}{4} \Big|_0^R = \frac{1}{2} k \pi R^4;$$

$$z_c = \frac{2}{k \pi R^4} k \iiint_V z \sqrt{x^2 + y^2 + z^2} dx dy dz = \frac{2}{\pi R^4} \iiint_V r^4 \sin \theta \cos \theta dr d\varphi d\theta =$$

$$= \frac{2}{\pi R^4} \int_0^{2\pi} d\varphi \int_0^{\frac{\pi}{2}} \sin \theta \cos \theta d\theta \int_0^R r^4 dr = \frac{2}{\pi R^4} \varphi \Big|_0^{2\pi} \cdot \frac{\sin^2 \theta}{2} \Big|_0^{\frac{\pi}{2}} \cdot \frac{r^5}{5} \Big|_0^R = \frac{2R}{5}; \quad c \left(0; 0; \frac{2R}{5} \right). \quad \bullet$$

9-misol. $x=0, y=0, z=0, x+y+z=3$ sirtlar bilan chegaralangan bir jinsli piramidaning Oy o'qqa nisbatan inersiya momentini hisoblang.

☞ Inersiya momentini $I_y = \iiint_V (x^2 + z^2) \gamma(x, y, z) dx dy dz$ formula bilan topamiz:

$$I_y = \gamma \iiint_V (x^2 + z^2) dx dy dz = \gamma \int_0^1 dx \int_0^{1-x} dz \int_0^{1-x-z} (x^2 + z^2) dy = \gamma \int_0^1 dx \int_0^{1-x} (x^2 + z^2)(1-x-z) dz =$$

$$= \gamma \int_0^1 dx \int_0^{1-x} (x^2(1-x) - x^2 z - (1-x)z^2 - z^3) dz =$$

$$= \gamma \int_0^1 \left(x^2(1-x)z - x^2 \frac{z^2}{2} - (1-x) \frac{z^3}{3} - \frac{z^4}{4} \right) \Big|_0^{1-x} dx = \gamma \int_0^1 \left(\frac{x^2}{2} - x^3 + \frac{x^4}{2} + \frac{(1-x)^4}{12} \right) dx =$$

$$= \gamma \left(\frac{x^3}{6} - \frac{x^4}{4} + \frac{x^5}{10} - \frac{(1-x)^5}{60} \right) \Big|_0^1 = \frac{1}{30} \gamma. \quad \bullet$$

Mashqlar

2.2.1. Uch karrali integrallarni hisoblang:

- 1) $\int_0^2 dx \int_0^1 dy \int_1^3 (2x + 3y - z^3) dz;$
- 2) $\int_0^2 dx \int_1^x dy \int_0^1 xye^z dz;$
- 3) $\int_0^3 dx \int_0^{2x} dy \int_0^{\sqrt{xy}} z dz;$
- 4) $\int_0^1 dy \int_0^y dx \int_0^{\sqrt{x^2+y^2}} z dz.$

2.2.2. Berilgan sirtlar bilan chegaralangan V sohada uch karrali integrallarni hisoblang:

- 1) $\iiint_V x dx dy dz, V: x=0, y=0, y=3, z=0, x+z=2;$
- 2) $\iiint_V xyz dx dy dz, V: x=0, y=0, z=0, x+y+z=1;$
- 3) $\iiint_V \frac{z^2}{1+e^{3xy}} dx dy dz, V: x=0, x=1, y=0, y=x, z=-1, z=e^{xy};$
- 4) $\iiint_V \frac{dx dy dz}{\sqrt{4y-2xy-zy}}, V: x=0, y=0, z=0, 2x+y+z=4;$
- 5) $\iiint_V (x^2+y^2) dx dy dz, V: z=2, z=\frac{x^2+y^2}{2};$
- 6) $\iiint_V z\sqrt{x^2+y^2} dx dy dz, V: y=0, y=\sqrt{2x-x^2}, z=0, z=3;$
- 7) $\iiint_V \frac{dx dy dz}{\sqrt{x^2+y^2}}, V: x^2+y^2=4y, y+z=4, z=0;$
- 8) $\iiint_V (x^2+y^2) dx dy dz, V: x^2+y^2=x, z=0, z^2=2x;$
- 9) $\iiint_V (x^2+y^2) dx dy dz, V: x^2+y^2+z^2=4, z \geq 0;$
- 10) $\iiint_V xyz^2 dx dy dz, V: x^2+y^2+z^2=1, x \geq 0, y \geq 0, z \geq 0.$

2.2.3. Berilgan sirtlar bilan chegaralangan jism hajmini hisoblang:

- 1) $x=1, y=x, y=2x, z=x^2+y^2, z=x^2+2y^2;$
- 2) $x=0, y=0, x+2y+z=6;$
- 3) $z=x^2+y^2, z=8-x^2-y^2;$
- 4) $(x^2+y^2+z^2)^2=xyz.$

2.2.4. $z^2=x^2+y^2$ konus va $z=1$ tekislik bilan chegaralangan jismning har bir nuqtasidagi zichligi uning applikatasiga proporsional bo'lsa, jismning massasini toping.

2.2.5. $2z = 4 - x^2 - y^2$ paraboloid va $z = 0$ tekislik bilan chegaralangan bir jinsli jism og'irlik markazining koordinatalarini toping.

2.2.6. R radiusli bir jinsli yarim shar og'irlik markazining koordinatalarini toping.

2.2.7. Radiusi R ga va og'irligi P ga teng bo'lgan bir jisimli sharning markaziga va diametriga nisbatan inersiya momentlarini toping.

2.2.8. $z^2 = 2ax$, $z = 0$, $x^2 + y^2 = ax$ sirtlar bilan chegaralangan bir jinsli jismning Oz o'qqa nisbatan inersiya momentini toping.

2.3. EGRI CHIZIQLI INTEGRALLAR

Birinchi tur egri chiziqli integral. Birinchi tur egri chiziqli integralni hisoblash. Ikkinchi tur egri chiziqli integral.

Ikkinchi tur egri chiziqli integralni hisoblash.

Egri chiziqli integrallarning tatbiqlari

📌 **2.3.1.** R^3 fazoda koordinatalari biror $t \in R$ parametrning $x = x(t)$, $y = y(t)$, $z = z(t)$ tenglamalari bilan berilgan $M(x, y, z)$ nuqtalar to'plamiga R^3 fazodagi L egri chiziq deyiladi. Bunda: agar $x = x(t)$, $y = y(t)$, $z = z(t)$ funksiyalar $t \in [\alpha; \beta]$ da uzluksiz bo'lsa L egri chiziq $[\alpha; \beta]$ kesmada *uzluksiz* deyiladi; agar $x = x(t)$, $y = y(t)$, $z = z(t)$ funksiyalar $t \in [\alpha; \beta]$ da uzluksiz, birinchi tartibli $x'(t)$, $y'(t)$, $z'(t)$ hosilalarga ega va $x'^2(t) + y'^2(t) + z'^2(t) \neq 0$ bo'lsa L egri chiziq $[\alpha; \beta]$ kesmada *silliq* deyiladi; agar $[\alpha; \beta]$ kesmaning chekli nuqtalarida $x'(t)$, $y'(t)$, $z'(t)$ hosilalar mavjud bo'lmasa yoki bir vaqtda nolga teng bo'lsa L egri chiziq $[\alpha; \beta]$ kesmada *bo'lakli-silliq* deyiladi; agar $x(\alpha) = x(\beta)$, $y(\alpha) = y(\beta)$, $z(\alpha) = z(\beta)$ bo'lsa L ga $[\alpha; \beta]$ kesmada *yopiq kontur* deyiladi.

$f(x, y, z)$ funksiya $AB \subset R^3$ silliq yoki bo'lakli-silliq egri chiziqning har bir nuqtasida aniqlangan va uzluksiz bo'lsin.

AB egri chiziqni ixtiyoriy ravishda $A = A_0, A_1, \dots, A_{i-1}, A_i, \dots, A_n = B$ nuqtalar bilan $\bigcup_{i=1}^n A_{i-1}A_i$ uzunliklari Δl_i ga teng bo'lgan n ta $(i = \overline{1, n})$ yoylarga bo'lamiz.

Har bir $\overset{\frown}{A_{i-1}A_i}$ yoyda ixtiyoriy $M(x_i; y_i; z_i)$ nuqtani tanlaymiz, $f(x, y, z)$ funksiyaning bu nuqtadagi qiymati $f(x_i, y_i, z_i)$ ni hisoblab, uni Δl_i ga ko'paytiramiz va barcha bunday ko'paytmalarning yig'indisini tuzamiz:

$$I = \sum_{i=1}^n f(x_i, y_i, z_i) \Delta l_i. \quad (3.1)$$

Agar (3.1) integral yig'indining $\max \Delta l_i \rightarrow 0$ dagi chekli limiti AB egri chiziqni bo'laklarga bo'lish usuliga va bu bo'laklarda $M(x_i; y_i; z_i)$ nuqtani tanlash usuliga bog'liq bo'lmagan holda mavjud bo'lsa, bu limitga $f(x, y, z)$ funksiyaning *birinchi tur egri chiziqli integrali* (yoki *yoy uzunligi bo'yicha integrali*) deyiladi va $\int_{\overset{\frown}{AB}} f(x, y, z) dl$ bilan belgilanadi:

$$\int_{\overset{\frown}{AB}} f(x, y, z) dl = \lim_{\max \Delta l_i \rightarrow 0} \sum_{i=1}^n f(x_i, y_i, z_i) \Delta l_i. \quad (3.2.)$$

1-teorema (*funksiya integrallanuvchi bo'lishining etarli sharti*). Agar $f(x, y, z)$ funksiya AB silliq egri chiziq bo'ylab uzluksiz bo'lsa, u holda u shu egri chiziqda integrallanuvchi bo'ladi.

$\overset{\frown}{A_{i-1}A_i}$ yoyning Δl_i uzunligi A, B nuqtalardan qaysi biri yoyning boshi va qaysi biri uning oxiri uchun qabul qilinishiga bog'liq bo'lmaydi.

Shu sababli

$$\int_{\overset{\frown}{AB}} f(x, y, z) dl = \int_{\overset{\frown}{BA}} f(x, y, z) dl.$$

Birinchi tur egri chiziqli integral aniq integralning boshqa xossalari ega.

2.3.2. AB egri chiziq fazoda parametrik tenglamalar bilan berilgan, ya'ni

$$\overset{\frown}{AB} = \{(x, y, z) \in R^3 \mid x = x(t), y = y(t), z = z(t), t \in [\alpha; \beta]\}$$

va $[\alpha; \beta]$ kesmada silliq (yoki bo'lakli silliq) bo'lsa birinchi tur egri chiziqli integral

$$\int_{\overset{\frown}{AB}} f(x, y, z) dl = \int_{\alpha}^{\beta} f(x(t), y(t), z(t)) \sqrt{x'^2(t) + y'^2(t) + z'^2(t)} dt \quad (3.3)$$

formula bilan hisoblanadi.

$\overset{\frown}{AB} = \{(x, y) \in R^2 \mid x = x(t), y = y(t), t \in [\alpha; \beta]\}$ tekislikdagi yassi egri chiziq uchun

$$\int_{\overset{\frown}{AB}} f(x, y) dl = \int_{\alpha}^{\beta} f(x(t), y(t)) \sqrt{x'^2(t) + y'^2(t)} dt. \quad (3.4)$$

Yassi egri chiziq tenglamasi qutb koordinatalarida berilgan, ya'ni $\overset{\cup}{AB} = \{(r; \varphi) : r = r(\varphi), \varphi_1 \leq \varphi \leq \varphi_2\}$ va $r'(\varphi)$ hosila AB egri chiziqda uzluksiz bo'lsa

$$\int_{\overset{\cup}{AB}} f(x, y) dl = \int_{\varphi_1}^{\varphi_2} f(r \cos \varphi, r \sin \varphi) \sqrt{r'^2(\varphi) + r^2(\varphi)} d\varphi \quad (3.5)$$

bo'ladi.

Agar yassi egri chiziq $[a; b]$ kesmada hosilasi bilan birgalikda uzluksiz $y = y(x)$ funksiya bilan berilgan, ya'ni $\overset{\cup}{AB} = \{(x; y) \in R^2 : y = y(x), x \in [a; b]\}$ bo'lsa

$$\int_{\overset{\cup}{AB}} f(x, y) dl = \int_a^b f(x, y(x)) \sqrt{1 + y'^2(x)} dx \quad (3.6)$$

bo'ladi.

1-misol. Birinchi tur egri chizikli integrallarni hisoblang:

1) $\int_{\overset{\cup}{AB}} \sqrt{2y} dl$, bu yerda $\overset{\cup}{AB} : x = a(t - \sin t), y = a(1 - \cos t), 0 \leq t \leq \pi$ sikloida yoyi;

2) $\int_{\overset{\cup}{AB}} (x^2 + y^2) dl$, bu yerda $\overset{\cup}{AB} : r = 1 - \cos \varphi$ kardioida yoyi;

3) $\int_{\overset{\cup}{AB}} x^2 dl$, bu yerda $\overset{\cup}{AB} : y = \ln x, 1 \leq x \leq 2$ egri chiziq bo'lagi;

4) $\int_{\overset{\cup}{AB}} (x - y)z dl$, bu yerda $\overset{\cup}{AB} : A(1; 2; -1)$ va $B(2; 0; 1)$ nuqtalarni tutashtiruvchi to'g'ri chiziq kesmasi;

5) $\oint_l (x + y) dl$, bu yerda l : uchlari $O(0; 0), A(2; 0), B(0; 2)$ nuqtalardan iborat uchburchak konturi.

☞ 1) Yassi egri chiziqning differensial formulasi bilan topamiz:

$$dl = \sqrt{x'^2 + y'^2} = \sqrt{a^2(1 - \cos t)^2 + a^2 \sin^2 t} dt = a\sqrt{2(1 - \cos t)} dt.$$

U holda

$$\begin{aligned} \int_{\overset{\cup}{AB}} \sqrt{2y} dl &= \int_0^\pi \sqrt{2a(1 - \cos t)} \cdot a\sqrt{2(1 - \cos t)} dt = 2a\sqrt{a} \int_0^\pi (1 - \cos t) dt = \\ &= 2a\sqrt{a} (t - \sin t) \Big|_0^\pi = 2\pi a\sqrt{a}. \end{aligned}$$

2) Chiziq tenglamasi qutb koordinatalarida berilgan.

Kardioida uchun $0 \leq \varphi \leq 2\pi$.

U holda

$$x^2 + y^2 = r^2 = (1 - \cos \varphi)^2 = 4 \sin^4 \frac{\varphi}{2},$$

$$dl = \sqrt{(1 - \cos \varphi)^2 + \sin^2 \varphi} d\varphi = \sqrt{2(1 - \cos \varphi)} d\varphi = 2 \sin \frac{\varphi}{2} d\varphi.$$

Bundan

$$\begin{aligned} \int_{AB} (x^2 + y^2) dl &= 8 \int_0^{2\pi} \sin^4 \frac{\varphi}{2} \sin \frac{\varphi}{2} d\varphi = 8 \int_0^{2\pi} \left(1 - \cos^2 \frac{\varphi}{2}\right)^2 \sin \frac{\varphi}{2} d\varphi = \\ &= 8 \int_0^{2\pi} \sin \frac{\varphi}{2} d\varphi + 32 \int_0^{2\pi} \cos^2 \frac{\varphi}{2} d\left(\cos \frac{\varphi}{2}\right) - 16 \int_0^{2\pi} \cos^4 \frac{\varphi}{2} d\left(\cos \frac{\varphi}{2}\right) = \\ &= -16 \cos \frac{\varphi}{2} \Big|_0^{2\pi} + \frac{32}{3} \cos^3 \frac{\varphi}{2} \Big|_0^{2\pi} - \frac{16}{5} \cos^5 \frac{\varphi}{2} \Big|_0^{2\pi} = \\ &= -16 \cdot (-2) + \frac{32}{3} \cdot (-2) - \frac{16}{5} \cdot (-2) = \frac{256}{15}. \end{aligned}$$

3) $y = \ln x$ uchun $y' = \frac{1}{x}$ va $dl = \sqrt{1 + \frac{1}{x^2}} dx = \frac{1}{x} \sqrt{1 + x^2} dx$. U holda

$$\begin{aligned} \int_{AB} x^2 dl &= \int_1^2 x^2 \cdot \frac{1}{x} \sqrt{1 + x^2} dx = \int_1^2 x \sqrt{1 + x^2} dx = \frac{1}{2} \int_1^2 (1 + x^2)^{\frac{1}{2}} d(1 + x^2) = \\ &= \frac{1}{2} \cdot \frac{2}{3} (1 + x^2)^{\frac{3}{2}} \Big|_1^2 = \frac{1}{3} (5\sqrt{5} - 2\sqrt{2}). \end{aligned}$$

4) l egri chiziq yoyining parametrik tenglamasini ikki nuqtadan o'tuvchi to'g'ri chiziq tenglamasidan topamiz:

$$\frac{x-1}{2-1} = \frac{y-2}{0-2} = \frac{z+1}{1+1} = t \quad \text{dan} \quad x = t+1, \quad y = -2t+2, \quad z = 2t-1,$$

bu yerda $0 \leq t \leq 1$.

U holda

$$\begin{aligned} \int_{AB} (x-y)z dl &= \int_0^1 (t+1+2t-2)(2t-1)\sqrt{1+4+4} dt = 3 \int_0^1 (3t-1)(2t-1) dt = \\ &= 3 \int_0^1 (6t^2 - 5t + 1) dt = 3 \left(2t^3 - \frac{5t^2}{2} + t \right) \Big|_0^1 = \frac{3}{2}. \end{aligned}$$

5) Integralning additivlik xossasiga ko'ra

$$\oint_l (x+y) dl = \int_{OA} (x+y) dl + \int_{AB} (x+y) dl + \int_{BO} (x+y) dl.$$

Har bir integralni alohida hisoblaymiz.

OA kesmada: $y=0$, $0 \leq x \leq 2$ va $dl = dx$.

U holda

$$\int_{\overset{\circ}{OA}} (x+y)dl = \int_0^2 x dx = \frac{x^2}{2} \Big|_0^2 = 2.$$

AB kesmada: $y=2-x$, $0 \leq x \leq 2$ va $y=-1$.

Bundan

$$\int_{\overset{\circ}{AB}} (x+y)dl = \int_0^2 2\sqrt{1+1}dx = 2\sqrt{2}x \Big|_0^2 = 4\sqrt{2}.$$

OB kesmada: $x=0$, $0 \leq y \leq 2$ va $dl=dy$. U holda

$$\int_{\overset{\circ}{OB}} (x+y)dl = \int_{\underset{\circ}{BO}} (x+y)dl = \int_0^2 y dy = \frac{y^2}{2} \Big|_0^2 = 2.$$

Demak,

$$\oint_I (x+y)dl = 2 + 4\sqrt{2} + 2 = 4(1 + \sqrt{2}). \quad \bullet$$

2.3.3. *Oxyz* fazoda boshi A nuqtada va oxiri B nuqtada bo'lgan AB silliq yoki bo'lakli-silliq yo'nalgan egri chiziq berilgan va bu chiziqning har bir $M(x; y; z)$ nuqtasida

$$\vec{a}(M) = P(M)\vec{i} + Q(M)\vec{j} + R(M)\vec{k}$$

vektor funksiya aniqlangan va uzluksiz bo'lsin.

AB egri chiziqni ixtiyoriy ravishda A dan B ga qarab yo'nalishda $A = A_0, A_1, \dots, A_{i-1}, A_i, \dots, A_n = B$ nuqtalar bilan uzunliklari Δl_i ga teng bo'lgan n ta $\overset{\circ}{A_{i-1}A_i}$ ($i = \overline{1, n}$) yoylarga bo'lamiz. Har bir $\overset{\circ}{A_{i-1}A_i}$ yoyda ixtiyoriy $M(x_i; y_i; z_i)$ nuqtani tanlaymiz, $\vec{a}(M)$ vektor funksiyaning bu nuqtadagi qiymati $\vec{a}(x_i, y_i, z_i)$ ni hisoblaymiz va

$$I = \sum_{i=1}^n ((P(x_i, y_i, z_i)\Delta x_i + Q(x_i, y_i, z_i)\Delta y_i + R(x_i, y_i, z_i)\Delta z_i)) \quad (3.7)$$

integral yig'indini tuzamiz, bu yerda $\Delta x_i = x_i - x_{i-1}$, $\Delta y_i = y_i - y_{i-1}$,

$\Delta z_i = z_i - z_{i-1} - \overset{\circ}{A_{i-1}A_i}$ yoyning koordinata o'qlaridagi proeksiyalari.

Agar (3.7) integral yig'indining $\max \Delta l_i \rightarrow 0$ dagi chekli limiti AB egri chiziqni bo'laklarga bo'lish usuliga va bu bo'laklarda $M(x_i; y_i; z_i)$ nuqtani tanlash usuliga bog'liq bo'lmagan holda mavjud bo'lsa, bu limitga $\vec{a}(M)$ vektor funksiyaning *ikkinchi tur egri chizikli integrali* deyiladi va

$$\int_{AB} P(x, y, z)dx + Q(x, y, z)dy + R(x, y, z)dz$$

bilan belgilanadi.

Demak,

$$\int_{AB} P(x, y, z)dx + Q(x, y, z)dy + R(x, y, z)dz = \\ = \lim_{\max \Delta_i \rightarrow 0} \left(\sum_{i=1}^n (P(x_i, y_i, z_i)\Delta x_i + Q(x_i, y_i, z_i)\Delta y_i + R(x_i, y_i, z_i)\Delta z_i) \right), \quad (3.8)$$

bu yerda $\int_{AB} P(x, y, z)dx$, $\int_{AB} Q(x, y, z)dy$, $\int_{AB} R(x, y, z)dz$ – mos ravishda $P(x, y, z)$, $Q(x, y, z)$, $R(x, y, z)$ funksiyaning x, y, z o‘zgaruvchi bo‘yicha egri chiziqli integrali deb ataladi.

$\vec{a} = P\vec{i} + Q\vec{j} + R\vec{k}$ vektor funksiyaning egri chiziqli integralini vektor ko‘rinishda $\int_{AB} \vec{a}d\vec{r}$ kabi yoziladi.

$L(AB)$ yopiq kontur bo‘yicha olingan egri chiziqli integral aylanib o‘tish yo‘nalishi ko‘rsatilgan holda

$$\oint_L P(x, y, z)dx + Q(x, y, z)dy + R(x, y, z)dz$$

kabi belgilanadi. Bunda L yopiq konturni aylanib o‘tish soat strelkasi yo‘nalishiga teskari bo‘lsa integrallash yo‘nalishi musbat hisoblanadi, aks holda manfiy hisoblanadi.

2-teorema (*funksiya integrallanuvchi bo‘lishining etarli sharti*). Agar $\vec{a}(M)$ vektor funksiya AB silliq egri chiziq bo‘ylab uzluksiz bo‘lsa, u holda u shu egri chiziqda integrallanuvchi bo‘ladi.

AB egri chiziq Oxy tekislikda yotsa ikkinchi tur egri chiziqli integral

$$\int_{AB} P(x, y)dx + Q(x, y)dy$$

bo‘ladi.

2.3.4. AB egri chiziq fazoda parametrik tenglamalar bilan berilgan, ya’ni

$$AB = \{(x, y, z) \in R^3 \mid x = x(t), y = y(t), z = z(t), t \in [\alpha; \beta]\}$$

va $[\alpha; \beta]$ kesmada silliq yoki bo‘lakli silliq bo‘lsin. Bunda t parametr boshlang‘ich A nuqtaga mos $\alpha = t_A$ qiymatdan oxirgi B nuqtaga mos $\beta = t_B$ qiymatgacha o‘zgarsin. U holda ikkinchi tur egri chiziqli integral

$$\int_{AB} P(x, y, z)dx + Q(x, y, z)dy + R(x, y, z)dz = \\ = \int_{\alpha}^{\beta} (P(x(t), y(t), z(t))x'(t) + Q(x(t), y(t), z(t))y'(t) + R(x(t), y(t), z(t))z'(t)) dt \quad (3.9)$$

tenglik bilan topiladi.

Tekislikdagi $AB = \{(x, y) \in R^2 \mid x = x(t), y = y(t), t \in [\alpha; \beta]\}$ egri chiziq uchun

$$\int_{AB} P(x, y)dx + Q(x, y)dy = \int_{\alpha}^{\beta} (P(x(t), y(t))x'(t) + Q(x(t), y(t))y'(t)) dt. \quad (3.10)$$

Yassi egri chiziq tenglamasi qutb koordinatalarida berilgan, ya'ni $AB = \{(r; \varphi) : r = r(\varphi), \varphi_1 \leq \varphi \leq \varphi_2\}$ va $r'(\varphi)$ hosila AB egri chiziqda uzluksiz bo'lsa

$$\begin{aligned} \int_{AB} P(x, y)dx + Q(x, y)dy &= \\ &= \int_{\varphi_1}^{\varphi_2} (Q(r \cos \varphi, r \sin \varphi)r \cos \varphi - P(r \cos \varphi, r \sin \varphi)r \sin \varphi) d\varphi \end{aligned} \quad (3.11)$$

bo'ladi.

Agar yassi egri chiziq $[a; b]$ kesmada hosilasi bilan birgalikda uzluksiz $y = y(x)$ funksiya bilan berilgan, ya'ni $AB = \{(x; y) \in R^2 : y = y(x), x \in [a; b]\}$ bo'lsa

$$\int_{AB} P(x, y)dx + Q(x, y)dy = \int_{\alpha}^{\beta} (P(x, y(x)) + Q(x, y(x))y'(x)) dx \quad (3.12)$$

bo'ladi.

2-misol. Ikkinchi tur egri chiziqli integrallarni hisoblang:

1) $\int_{AB} ydx - xdy$, bu yerda $AB: x = 2(t - \sin t), y = 2(1 - \cos t), 0 \leq t \leq 2\pi$

sikloidaning bir arkasi;

2) $\oint_{AB} (x - y)dx + (x + y)dy$, bu yerda $AB: r = a\sqrt{\cos \varphi}$ limniskataning o'ng

yaprog'i;

3) $\int_{AB} x^2 y dx + xy^2 dy$, bu yerda $AB: y = x^2 + 1$ parabolaning $A(1; 2)$ dan $B(2; 5)$

nuqtalar orasidagi bo'lagi.

4) $\int_{AB} (z - y)dx + (x - z)dy + (y - x)dz$, bu yerda $AB: x = 2 \cos t, y = 2 \sin t, z = 3t,$

$0 \leq t \leq 2\pi$ vint chizig'ining birinchi o'rami.

☞ 1) $dx = 2(1 - \cos t), dy = 2 \sin t$ ni hisobga olib, topamiz:

$$\begin{aligned} \int_{AB} ydx - xdy &= \int_0^{2\pi} (4(1 - \cos t)^2 - 4(t - \sin t) \sin t) dt = 4 \int_0^{2\pi} (2 - 2 \cos t - t \sin t) dt = \\ &= 4(2t - 2 \sin t) \Big|_0^{2\pi} - 4 \left(-t \cos t \Big|_0^{2\pi} + \int_0^{2\pi} \cos t dt \right) = 16\pi + 8\pi - 4 \sin t \Big|_0^{2\pi} = 24\pi. \end{aligned}$$

2) Chiziq tenglamasi qutb koordinatalarida berilgan. Limniskataning o'ng yaprog'i uchun $-\frac{\pi}{4} \leq \varphi \leq \frac{\pi}{4}$.

$x = r \cos \varphi$, $y = r \sin \varphi$, $dx = -r \sin \varphi d\varphi$, $dy = r \cos \varphi d\varphi$ ni hisobga olib, topamiz:

$$\begin{aligned} & \oint_{AB} (x - y)dx + (x + y)dy = \\ & = \int_{-\frac{\pi}{4}}^{\frac{\pi}{4}} ((r \cos \varphi - r \sin \varphi) \cdot (-r \sin \varphi) + (r \cos \varphi + r \sin \varphi) \cdot r \cos \varphi) d\varphi = \\ & = \int_{-\frac{\pi}{4}}^{\frac{\pi}{4}} r^2 d\varphi = a^2 \int_{-\frac{\pi}{4}}^{\frac{\pi}{4}} \cos^2 \varphi d\varphi = \frac{1}{2} a^2 \int_{-\frac{\pi}{4}}^{\frac{\pi}{4}} (1 + \cos 2\varphi) d\varphi = \frac{1}{2} a^2 \left(\varphi + \frac{1}{2} \sin 2\varphi \right) \Big|_{-\frac{\pi}{4}}^{\frac{\pi}{4}} = \frac{1}{4} a^2 (\pi + 2). \end{aligned}$$

$$\begin{aligned} 3) \int_{AB} x^2 y dx + x y^2 dy &= \int_1^2 (x^2(x^2 + 1) + x(x^2 + 1)^2 \cdot 2x) dx = \\ &= \int_1^2 (x^4 + x^2 + 2x^2(x^4 + 2x^2 + 1)) dx = \int_1^2 (2x^6 + 5x^4 + 3x^2) dx = \left(\frac{2}{7} x^7 + x^5 + x^3 \right) \Big|_1^2 = \frac{520}{7}. \end{aligned}$$

$$\begin{aligned} 4) \int_{AB} (z - y)dx + (x - z)dy + (y - x)dz &= \\ &= \int_0^{2\pi} ((3t - 2 \sin t) \cdot (-2 \sin t) + (2 \cos t - 3t) \cdot 2 \cos t + 2(\sin t - \cos t) \cdot 3) dt = \\ &= \int_0^{2\pi} (4 - 6(t(\sin t + \cos t) + (\sin t - \cos t))) dt = \\ &= \int_0^{2\pi} 4 dt - 6 \int_0^{2\pi} (t(\sin t + \cos t) + (\sin t - \cos t)) dt = \\ &= 4t \Big|_0^{2\pi} - 6 \int_0^{2\pi} d(t(\sin t - \cos t)) = 8\pi - 6(t(\sin t - \cos t)) \Big|_0^{2\pi} = 20\pi. \end{aligned}$$

⇒ $Oxyz$ fazoda boshi A nuqtada va oxiri B nuqtada bo'lgan AB yo'nalgan silliq yoki bo'lakli-silliq egri chiziq berilgan bo'lsin. AB egri chiziqqa $M(x, y, z)$ nuqtada o'tkazilgan urinmaning koordinata o'qlari bilan tashkil qilgan burchaklari $\alpha = \alpha(x, y, z)$, $\beta = \beta(x, y, z)$, $\gamma = \gamma(x, y, z)$ bo'lsin.

Bunda birinchi va ikkinchi tur egri chiziqli integral

$$\begin{aligned} & \int_{AB} P(x, y, z) dx + Q(x, y, z) dy + R(x, y, z) dz = \\ & = \int_{AB} (P(x, y, z) \cos \alpha + Q(x, y, z) \cos \beta + R(x, y, z) \cos \gamma) dl \end{aligned} \quad (3.13)$$

bog'lanishga ega bo'ladi.

Xususan, AB tekislikdagi yassi egri chiziq uchun

$$\int_{AB} P(x, y) dx + Q(x, y) dy = \int_{AB} (P(x, y) \cos \alpha + Q(x, y) \cos \beta) dl. \quad (3.14)$$

⇒ $D \subset R^2$ soha berilgan bo'lib, uning chegarasi L bo'lakli-silliqlik chiziqdan iborat bo'lsin.

3-teorema. Agar $P(x, y)$ va $Q(x, y)$ funksiyalar D sohada o'zlarining xususiy hosilalari bilan birgalikda uzluksiz bo'lsa, u holda

$$\oint_L P(x, y)dx + Q(x, y)dy = \iint_D \left(\frac{dQ}{dx} - \frac{dP}{dy} \right) dx dy \quad (3.15)$$

bo'ladi.

Bu tenglikka *Grin formulasi* deyiladi. Bu formula ikkinchi tur egri chiziq bilan ikki karrali integral orasidagi bog'lanishni beradi

3-misol. Integralni Grin formulasi bilan hisoblang:

$\int_{AB} (2 + x - y)dx + (3x + y + 1)dy$, bu yerda $AB: x^2 + y^2 = ax$ aylana.

⊕ $P(x, y) = 2 + x - y$, $Q(x, y) = 3x + y + 1$ funksiyalar va ularning $\frac{\partial P}{\partial y} = -1$, $\frac{\partial Q}{\partial x} = 3$ xususiy hosilalari $x^2 + y^2 = ax$ aylana bilan chegaralangan doirada uzluksiz. U holda Grin formulasiga ko'ra

$$\int_{AB} (2 + x - y)dx + (3x + y + 1)dy = \iint_D (3 - (-1))dx dy = 4 \iint_D dx dy = 4S,$$

bu yerda S – doiraning yuzasi.

Aylana tenglamasidan topamiz:

$$x^2 + y^2 - ax = 0 \text{ yoki } \left(x - \frac{a}{2}\right)^2 + y^2 = \left(\frac{a}{2}\right)^2. \text{ Bundan } S = \frac{\pi a^2}{4}.$$

Demak,

$$\int_{AB} (2 + x - y)dx + (3x + y + 1)dy = \pi a^2. \quad \ominus$$

4-teorema. $P(x, y)$ va $Q(x, y)$ funksiyalar bir bog'lamli D sohada Grin teoremasining shartlarini bajarsin. U holda quyidagi to'rtta tasdiq ekvivalent bo'ladi:

1. D sohadagi istalgan L yopiq kontur uchun $\oint_L Pdx + Qdy = 0$ bo'ladi.

2. Ixtiyoriy $A, B \in D$ nuqtalarni tutashtiruvchi AB yoy uchun $\int_{AB} Pdx + Qdy$

integralning qiymati integrallash yo'liga bog'liq bo'lmaydi. Bunda eng qulay integrallash yo'li sifatida A va B nuqtalarni tutashtiruvchi hamda qismlari Ox va Oy o'qlariga parallel siniqlik chiziq olinishi mumkin.

3. D sohada $\frac{dP}{dy} = \frac{dQ}{dx}$ bo'ladi.

4. $P(x, y)dx + Q(x, y)dy$ ifoda to'liq defferensial bo'ladi, ya'ni shunday $u(x, y) \in D$ funksiya topiladiki $du = Pdx + Qdy$ tenglik bajariladi. Bunda $u(x, y)$ funksiya

$$u(x, y) = \int_{x_0}^x P(x, y)dx + \int_{y_0}^y Q(x_0, y)dy + C \text{ yoki } u(x, y) = \int_{x_0}^x P(x_0, y)dx + \int_{y_0}^y Q(x, y)dy + C$$

ifodalarning biridan topiladi, bu yerda $M_0(x_0; y_0)$, $M(x; y) - D$ sohada yotuvchi nuqtalar, $C - o'zgarimas son$.

4-misol. $I = \int_{AB} (x + 3y)dx + (y + 3x)dy$ integralni $A(0;0)$ nuqtadan $B(1;1)$

nuqtagacha hisoblang: 1) $y = x$ to'g'ri chiziq kesmasi bo'yicha; 2) $y = x^2$ parabola yoyi bo'yicha; 3) $y^2 = x$ parabola yoyi bo'yicha.

$$\odot P(x, y) = x + 3y, Q(x, y) = y + 3x \text{ uchun } \frac{dP}{dy} = 3 \text{ va } \frac{dQ}{dx} = 3, \text{ ya'ni}$$

$$\frac{dP}{dy} = \frac{dQ}{dx}. \text{ Demak, berilgan integral integrallash yo'liga bog'liq bo'lmaydi}$$

va integrallashning boshlang'ich va oxirgi nuqtalari bilan aniqlanadi.

Integralni uchta chiziq bo'yicha hisoblaymiz:

1) to'g'ri chiziq tenglamasi $y = x$ va $dy = dx$. U holda

$$I = \int_0^1 (x + 3x)dx + (x + 3x)dx = 4x^2 \Big|_0^1 = 4.$$

2) parabola yoyi $y = x^2$ va $dy = 2xdx$. Bundan

$$I = \int_0^1 (x + 3x^2)dx + (x^2 + 3x)2xdx = \int_0^1 (x + 9x^2 + 2x^3)dx = \left(\frac{x^2}{2} + 3x^3 + \frac{x^4}{2} \right) \Big|_0^1 = 4.$$

3) parabola yoyi $x = y^2$ va $dx = 2ydy$. U holda

$$I = \int_0^1 (y^2 + 3y)2ydy + (y + 3y^2)dy = \int_0^1 (y + 9y^2 + 2y^3)dx = \left(\frac{y^2}{2} + 3y^3 + \frac{y^4}{2} \right) \Big|_0^1 = 4. \odot$$

5-misol. $du = (4x^2y^3 - 3y^2 + 8)dx + (3x^4y^2 - 6xy - 1)dy$ to'liq differensialga ko'ra funksiyaning toping.

$$\odot P = 4x^2y^3 - 3y^2 + 8, Q = 3x^4y^2 - 6xy - 1. \text{ Bundan}$$

$$\frac{dP}{dy} = 12x^2y^2 - 6y = \frac{dQ}{dx}.$$

Boshlang'ich $(x_0; y_0)$ nuqta sifatida $O(0;0)$ nuqtani olamiz.

U holda

$$u = \int_0^x 8dx + \int_0^y (3x^4y^2 - 6xy - 1)dy + C \text{ yoki } u = 8x + x^4y^3 - 3xy^2 - y + C. \odot$$

2.3.7. Egri chiziqning uzunligi. Tekis yoki fazoviy AB egri chiziqning uzunligi

$$l = \int_{AB} dl \quad (3.16)$$

formula bilan topiladi (birinchi tur egri chizikli integralning *geometrik* ma'nosi).

Silindrik sirtning yuzasi. Yo'naltiruvchisi Oxy tekislikda yotuvchi AB egri chiziqdan, yasovchilari Oz o'qqa parallel bo'lgan to'g'ri chiziqlardan iborat va $z = f(x, y)$ funksiya bilan berilgan silindrik sirtning S yuzasi

$$S = \int_{AB} f(x, y) dl \quad (3.17)$$

integral bilan topiladi.

Yassi egri chiziqning yuzasi. Oxy tekislikda yotuvchi va L yopiq kontur bilan chegaralangan yassi figuraning yuzasi

$$S = \frac{1}{2} \oint_L x dy - y dx \quad (3.18)$$

bo'ladi (ikkinchi tur egri chizikli integralning *geometrik* ma'nosi).

Egri chiziqning massasi. AB material egri chiziqning massasi

$$l = \int_{AB} \gamma(M) dl \quad (3.19)$$

formula bilan topiladi (birinchi tur egri chizikli integralning *mexanik* ma'nosi), bu yerda $\gamma(M)$ – egri chiziqning M nuqtadagi zichligi.

Statik momentlar, og'irlik markazi. AB egri chiziqning Ox , Oy o'qlarga nisbatan statik momentlari va og'irlik markazining koordinatalari

$$S_x = \int_{AB} y \gamma(M) dl, \quad S_y = \int_{AB} x \gamma(M) dl, \quad x_c = \frac{S_y}{m}, \quad y_c = \frac{S_x}{m} \quad (3.20)$$

formulalar bilan topiladi.

Ihersiya momentlari. AB material egri chiziqning Ox , Oy o'qlarga va koordinata boshiga nisbatan inersiya momentlari mos ravishda quyidagilarga teng:

$$I_x = \int_{AB} y^2 \gamma(M) dl, \quad I_y = \int_{AB} x^2 \gamma(M) dl, \quad I_0 = \int_{AB} (x^2 + y^2) \gamma(M) dl. \quad (3.21)$$

O'zgaruvchan kuchning bajargan ishi. $\vec{F} = P\vec{i} + Q\vec{j} + R\vec{k}$ kuchning AB egri chiziq bo'ylab bajargan ishi

$$A = \int_{AB} \vec{F} d\vec{r} \quad (3.22)$$

kabi aniqlanadi (ikkinchi tur egri chizikli integralning *mexanik* ma'nosi).

6-misol. $x = a \cos^3 t$, $y = a \sin^3 t$ astroida bilan chegaralangan figura yuzasini hisoblang.

☞ Yuzani $S = \frac{1}{2} \oint_L xdy - ydx$ formula bilan hisoblaymiz.

Masala shartidan topamiz:

$$dy = 3a \sin^2 t \cos t dt, \quad dx = -3a \cos^2 t \sin t dt, \quad 0 \leq t \leq 2\pi.$$

Bundan

$$\begin{aligned} S &= \frac{1}{2} \oint_L xdy - ydx = \frac{1}{2} \int_0^{2\pi} (a \cos^3 t \cdot 3a \sin^2 t \cos t - a \sin^3 t \cdot (-3a \cos^2 t \sin t)) dt = \\ &= \frac{3a^2}{2} \int_0^{2\pi} \sin^2 t \cos^2 t (\cos^2 t + \sin^2 t) dt = \\ &= \frac{3a^2}{2} \int_0^{2\pi} \sin^2 t \cos^2 t dt = \frac{3a^2}{8} \int_0^{2\pi} \sin^2 2t dt = \frac{3a^2}{16} \int_0^{2\pi} (1 - \cos 4t) dt = \\ &= \frac{3a^2}{16} \left(t - \frac{1}{4} \sin 4t \right) \Big|_0^{2\pi} = \frac{3\pi a^2}{8}. \quad \text{☞} \end{aligned}$$

7-misol. $x^2 + y^2 = R^2$ ($x \geq 0, y \geq 0$) silindrning yuqoridan $xy = 2Rz$ sirt bilan kesilgan qismining yon sirtini toping.

☞ Izlanayotgan sirt yuzasi $z = \frac{xy}{2R}$ funksiyadan aylananing birinchi chorakdagi qismi bo'yicha olingan birinchi tur egri chiziqli integral bilan hisoblanadi: $S = \int_{AB} \frac{xy}{2R} dl$, bu yerda $\overset{\cup}{AB}$: $x = R \cos t$, $y = R \sin t$, $0 \leq t \leq \frac{\pi}{2}$.

U holda

$$\begin{aligned} S &= \int_{AB} \frac{xy}{2R} dl = \int_0^{\frac{\pi}{2}} \frac{R \cos t R \sin t}{2R} \sqrt{(R \cos t)' ^2 + (R \sin t)' ^2} dt = \\ &= \frac{R^2}{2} \int_0^{\frac{\pi}{2}} \sin t \cos t dt = \frac{R^2}{2} \cdot \frac{\sin^2 t}{2} \Big|_0^{\frac{\pi}{2}} = \frac{R^2}{4}. \quad \text{☞} \end{aligned}$$

8-misol. Agar vint chizig'ining zichligi $\gamma = \frac{1}{x^2 + y^2 + z^2}$ bo'lsa, uning birinchi o'rami massasini toping.

☞ Vint chizig'ining birinchi o'rami $x = a \cos t$, $y = a \sin t$, $z = bt$, $0 \leq \varphi \leq 2\pi$ parametrik tenglamalar bilan aniqlanadi.

U holda

$$\begin{aligned}
 m &= \int_{\overset{\cup}{AB}} \frac{dl}{x^2 + y^2 + z^2} = \int_0^{2\pi} \frac{\sqrt{(-a \sin t)^2 + (a \cos t)^2 + b^2}}{a^2 \cos^2 t + a^2 \sin^2 t + b^2 t^2} dt = \\
 &= \int_0^{2\pi} \frac{\sqrt{a^2 + b^2}}{a^2 + b^2 t^2} dt = \frac{\sqrt{a^2 + b^2}}{b} \int_0^{2\pi} \frac{d(bt)}{a^2 + (bt)^2} = \\
 &= \frac{\sqrt{a^2 + b^2}}{b} \cdot \frac{1}{a} \operatorname{arctg} \frac{bt}{a} \Big|_0^{2\pi} = \frac{\sqrt{a^2 + b^2}}{ab} \operatorname{arctg} \frac{2\pi b}{a}. \quad \odot
 \end{aligned}$$

9-misol. $\vec{F} = x^2 \vec{j}$ kuchning material nuqtani $y^2 = 1 - x$ parabola bo'ylab $A(1;0)$ nuqtadan $B(0;1)$ nuqtaga ko'chirishda bajargan ishini toping.

☉ Parabola tenglamasidan topamiz: $x = 1 - y^2$.

U holda

$$A = \int_{\overset{\cup}{AB}} \vec{F} d\vec{r} = \int_{\overset{\cup}{AB}} x^2 dy = \int_0^1 (1 - y^2)^2 dy = \int_0^1 (1 - 2y^2 + y^4) dy = \frac{8}{15}. \quad \odot$$

Mashqlar

2.3.1. Birinchi tur egri chiziqli integrallarni hisoblang:

- 1) $\int_{\overset{\cup}{AB}} (x + y) dl$, bu yerda $\overset{\cup}{AB}$: $A(0;0)$ va $B(4;3)$ nuqtalarni tutashtiruvchi to'g'ri chiziq kesmasi;
- 2) $\int_{\overset{\cup}{AB}} \frac{dl}{\sqrt{8 - x^2 - y^2}}$, bu yerda $\overset{\cup}{AB}$: $A(0;0)$ va $B(2;2)$ nuqtalarni tutashtiruvchi to'g'ri chiziq kesmasi;
- 3) $\int_{\overset{\cup}{AB}} y dl$, bu yerda $\overset{\cup}{AB}$: $y^2 = 2\sqrt{3}x$ parabolaning $x^2 = 2\sqrt{3}y$ parabola bilan kesilgan bo'lagi;
- 4) $\int_{\overset{\cup}{AB}} \sqrt{x^2 + y^2} dl$, bu yerda $\overset{\cup}{AB}$: $x^2 + y^2 = 4x$ aylana yoyi;
- 5) $\int_{\overset{\cup}{AB}} xy dl$, bu yerda $\overset{\cup}{AB}$: $3x + 4y = 12$ to'g'ri chiziqning koordinata o'qlari orasidagi kesmasi;
- 6) $\int_{\overset{\cup}{AB}} xy(x + y) dl$, bu yerda $\overset{\cup}{AB}$: $x^2 + y^2 = R^2$ aylananing yuqori yoyi;

7) $\int_{AB} y^2 dl$, bu yerda $\overset{\cup}{AB}: x = a(t - \sin t), y = a(1 - \cos t)$ sikloidaning bir arkasi;

8) $\int_{AB} \sqrt{x^2 + y^2} dl$, bu yerda $\overset{\cup}{AB}: r = a(1 + \cos \varphi)$ kardioida yoyi;

9) $\int_{AB} (x^2 + y^2 + z^2) dl$, bu yerda $\overset{\cup}{AB}: x = \cos t, y = \sin t, z = \sqrt{3}t$ ($0 \leq t \leq 2\pi$)

vint chizig'ining birinchi o'rami.

10) $\int_{AB} \frac{x dl}{3y + z}$, $\overset{\cup}{AB}: x = \frac{t^2}{\sqrt{2}}, y = \frac{t^3}{3}, z = t$ chiziqning $O(0;0;0)$ va $B\left(\sqrt{2}; \frac{2\sqrt{2}}{3}; \sqrt{2}\right)$ nuqtalar orasidagi yoyi.

2.3.2. Ikkinchi tur egri chizikli integrallarni hisoblang:

1) $\int_{AB} y^2 dx - xy dy$, bu yerda $AB: A(1;1)$ va $B(3;4)$ nuqtalarni tutashtiruvchi to'g'ri chiziq kesmasi;

2) $\int_{AB} y^2 dx - x^2 dy$, bu yerda $AB: y = x^2$ parabolaning $A(0;0)$ va $B(2;4)$ nuqtalar orasidagi yoyi;

3) $\int_{AB} \frac{y}{x} dx + x dy$, bu yerda $AB: y = \ln x$ egri chiziqning $A(1;0)$ va $B(e;1)$ nuqtalar orasidagi yoyi;

4) $\int_{AB} (ye^x + 2x) dx + e^x dy$, bu yerda $AB: y = xe^x$ egri chiziqning $A(0;0)$ va $B(1;e)$ nuqtalar orasidagi yoyi;

5) $\int_{AB} y^2 dx + x^2 dy$, bu yerda $AB: \frac{x^2}{a^2} + \frac{y^2}{b^2} = 1$ ellipsning $A(0;b)$ va $B(a;0)$ nuqtalar orasidagi yoyi;

6) $\oint_L x dy - y dx$ bu yerda a) $L: x^2 + y^2 = R^2$ aylana yoyi; b) $L: y = x^2, x = y^2$ parabolalar orasidagi egri chiziq yoyi; c) $L: x = 4 \cos^3 t, y = 4 \sin^3 t$ astroida yoyi; d) $L: x = 4 \cos t, y = 3 \sin t$ ellips yoyi.

7) $\int_{AB} x dx + y dy + (x - y + 1) dz$, bu yerda $AB: A(1;1;1)$ va $B(2;3;4)$ nuqtalarni tutashtiruvchi to'g'ri chiziq;

8) $\int_{AB} 2xy dx + y^2 dy + z^2 dz$, bu yerda $AB: x = \cos t, y = \sin t, z = 2t$ vint chizig'ining $A(1;0;0)$ va $B(1;0;4\pi)$ nuqtalar orasidagi yoyi.

2.3.3. Integrallarni aylanishning musbat yo‘nalishda Grin formulasi bilan hisoblang:

1) $\oint_L (x+y)^2 dx - (x^2 + y^2) dy$ bu yerda L : uchlari $O(0;0)$, $A(1;0)$ va $B(0;1)$ nuqtalardan iborat uchburchak konturi;

2) $\oint_L (1-x^2)y dx + x(1+y^2) dy$ bu yerda L : $x^2 + y^2 = R^2$ aylana yoyi.

2.3.4. Differensial tenglamaga ko‘ra boshlang‘ich funksiyani toping:

1) $du = (x + \sin y) dx + (x \cos y + \sin y) dy$; 2) $du = (y + e^x \sin y) dx + (x + e^x \cos y) dy$.

2.3.5. $x = t$, $y = \frac{t^2}{2}$, $z = \frac{t^3}{6}$, $0 \leq t \leq 3$ egri chiziqning uzunligini toping.

2.3.6. $x = 2 - \frac{t^4}{4}$, $y = \frac{t^6}{6}$ egri chiziqning koordinata o‘qlari orasidagi bo‘lagi uzunligini toping.

2.3.7. Zichligi $\gamma = 3\sqrt{r}$ ga teng bo‘lgan $r = 2(1 + \cos \varphi)$ kardioidaning massasini toping.

2.3.8. Bir jinsli sikloida yarim arkasining massasini toping.

2.3.9. $z = \sqrt{2x - 4x^2}$, $y^2 = 2x$ sirtlar va Oxy tekislik orasida joylashgan silindrik sirtning yuzasini toping.

2.3.10. $z = 2 - \sqrt{y}$, $x = \frac{2}{3}\sqrt{(y-1)^3}$ sirtlar va Oxy tekislik orasida joylashgan silindrik sirtning yuzasini toping.

2.3.11. $\frac{x^2}{a^2} + \frac{y^2}{b^2} = 1$ ellips bilan chegaralangan yassi shakl yuzasini toping.

2.3.12. $x = a(2\cos t - \cos 2t)$, $y = a(2\sin t - \sin 2t)$ kardioida bilan chegaralangan yassi shakl yuzasini toping.

2.3.13. $\vec{F} = -y\vec{i} + x\vec{j} + z\vec{k}$ kuchning material nuqtani vint chizig‘ining bir o‘rami bo‘ylab ko‘chirishda bajargan ishini toping.

2.3.14. $\vec{F} = xy\vec{i} + 2y^2\vec{j} - x^2\vec{k}$ kuchning material nuqtani $x^2 + y^2 = R^2$ aylananing birinchi chorakdagi yoyi bo‘ylab ko‘chirishda bajargan ishini toping.

2.4. SIRT INTEGRALLARI

**Birinchi tur sirt integrali. Birinchi tur sirt integralini hisoblash.
Ikkinhi tur sirt integrali. Ikkinchi tur sirt integralini hisoblash.
Sirt integrallarining tatbiqlari**

2.4.1. Bo‘lakli silliq kontur bilan chegaralangan ikki tomonli silliq (yoki bo‘lakli silliq) $\sigma \subset R^3$ sirtida $f(x, y, z)$ funksiya aniqlangan va uzluksiz bo‘lsin.

σ sirtini ixtiyoriy ravishda o‘tkazilgan egri chiziqlar to‘ri bilan yuzalari $\Delta\sigma_1, \Delta\sigma_2, \dots, \Delta\sigma_n$ bo‘lgan n ta σ_i bo‘lakka bo‘lamiz (12-shakl). Har bir σ_i sirtida ixtiyoriy $M(x_i; y_i; z_i)$ nuqtani tanlaymiz, $f(x, y, z)$ funksiyaning bu nuqtadagi qiymati $f(x_i, y_i, z_i)$ ni hisoblab, uni $\Delta\sigma_i$ ga ko‘paytiramiz va barcha bunday ko‘paytmalarning yig‘indisini tuzamiz:

$$\sum_{i=1}^n f(x_i, y_i, z_i) \Delta\sigma_i \quad (4.1)$$

☑ Agar (4.1) integral yig‘indining $\max d_i \rightarrow 0$ ($d_i - \Delta\sigma_i$ yuzaning diametri) dagi chekli limiti σ sirtini bo‘laklarga bo‘lish usuliga va bu bo‘laklarda

$M(x_i; y_i; z_i)$ nuqtani tanlash usuliga bog‘liq bo‘lmagan holda mavjud bo‘lsa, bu limitga $f(x, y, z)$ funksiyaning birinchi tur sirt integrali (yoki sirt yuzasi bo‘yicha integrali) deyiladi va $\iint_{\sigma} f(x, y, z) d\sigma$ bilan belgilanadi:

$$\iint_{\sigma} f(x, y, z) d\sigma = \lim_{\max d_i \rightarrow 0} \sum_{i=1}^n f(x_i, y_i, z_i) \Delta\sigma_i. \quad (4.2)$$

☑ Agar σ sirtning har bir nuqtasida urinma tekislik mavjud bo‘lsa va u sirt nuqtalari bo‘ylab uzluksiz o‘zgarsa σ sirtga *silliq sirt* deyiladi.

1-teorema (*funksiya integrallanuvchi bo‘lishining etarli sharti*). Agar $f(x, y, z)$ funksiya σ silliq sirtga uzluksiz bo‘lsa, u holda u shu sirtida integrallanuvchi bo‘ladi.

$\Delta\sigma_i$ yuza sirtning har ikki tomonida bir xil qiymatga ega bo‘lgani uchun birinchi tur sirt integrali σ sirt tomonining tanlanishiga bog‘liq bo‘lmaydi.

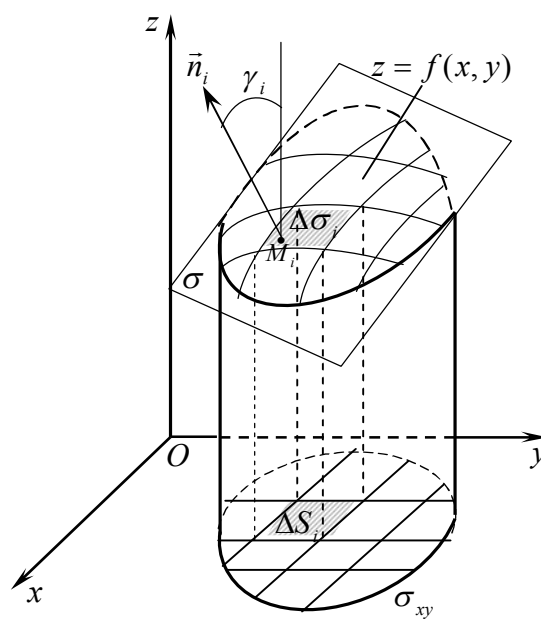

12-shakl.

Birinchi tur sirt integrali ikki karrali integral ega bo'lgan barcha xossalarga ega.

2.4.2. σ sirt $z = z(x, y)$ tenglama bilan berilgan bo'lib, bu sirtning Oxy tekislikdagi proyeksiyasi σ_{xy} bir o'lchamli bo'lsin, ya'ni Oz o'qqa parallel har qanday to'g'ri chiziq σ_{xy} sirtni faqat bitta nuqtada kesib o'tsin. $z = z(x, y)$ funksiya o'zining xususiy hosilalari bilan birgalikda σ_{xy} sohada uzluksiz bo'lsin. σ sirtning $\Delta\sigma_1, \Delta\sigma_2, \dots, \Delta\sigma_n$ bo'laklariga σ_{xy} proyeksiyada $\Delta S_1, \Delta S_2, \dots, \Delta S_n$ bo'laklar mos kelsin. σ sirtning $M_i(x_i; y_i; z_i)$ (bu yerda $z_i = z(x_i, y_i)$) nuqtasida sirtga o'tkazilgan normal $\vec{n} = \{z'_x(x_i, y_i); z'_y(x_i, y_i); -1\}$ vektor bilan aniqlansin (16-shakl).

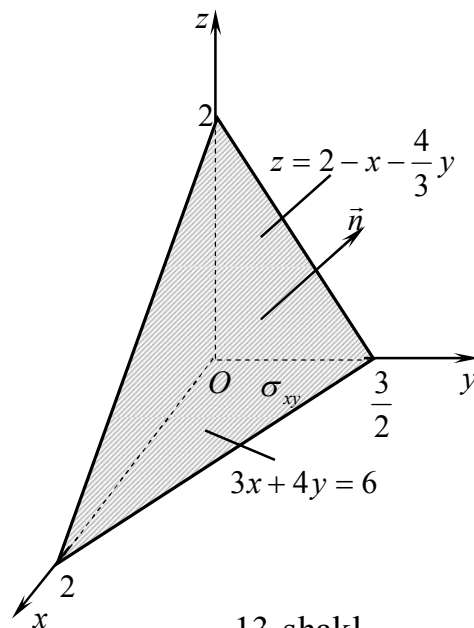

13-shakl.

U holda

$$\iint_{\sigma} f(x, y, z) d\sigma = \iint_{\sigma_{xy}} f(x, y, z(x, y)) \sqrt{1 + z_x'^2(x, y) + z_y'^2(x, y)} dx dy \quad (4.3)$$

birinchi tur sirt integralini hisoblash formulasi o'rinli bo'ladi.

1-misol. Birinchi tur sirt integrallarini hisoblang:

1) $\iint_{\sigma} (x - 4y + 3z) d\sigma$, bu yerda $\sigma: 3x + 4y + 3z - 6 = 0$ tekislikning birinchi oktantdagi qismi;

2) $\iint_{\sigma} (x^2 + y^2) d\sigma$, bu yerda $\sigma: z^2 = x^2 + y^2$ konus sirtning $z = 0$ va $z = 1$ tekisliklar orasidagi qismi;

3) $\iint_{\sigma} x^2 y^2 d\sigma$, bu yerda $\sigma: z = \sqrt{9 - x^2 - y^2}$ yarim sfera.

☉ 1) Sirt tenglamasidan topamiz:

$$z = 2 - x - \frac{4}{3}y, \quad z'_x = -1, \quad z'_y = -\frac{4}{3}.$$

σ sirtning Oxy tekislikdagi proyeksiyasi $3x + 4y = 6$ to'g'ri chiziq va koordinata o'qlari bilan chegaralangan uchburchakdan iborat (13-shakl).

U holda (4.3) formula bilan topamiz:

$$\iint_{\sigma} (x - 4y + 3z) d\sigma = \iint_{\sigma_{xy}} (6 - 2x - 8y) \sqrt{1 + 1 + \frac{16}{9}} dx dy = \frac{\sqrt{34}}{3} \int_0^2 dx \int_0^{\frac{6-3x}{4}} (6 - 2x - 8y) dy =$$

$$= \frac{\sqrt{34}}{3} \int_0^2 ((6-2x)y - 4y^2) \Big|_0^{6-3x} dx = \frac{\sqrt{34}}{12} \int_0^2 (6x - 3x^2) dx = (3x^2 - x^3) \Big|_0^2 = \frac{\sqrt{34}}{3}.$$

2) Shartga ko'ra: $z = \sqrt{x^2 + y^2}$. Bundan $z'_x = \frac{x}{\sqrt{x^2 + y^2}}$, $z'_y = \frac{y}{\sqrt{x^2 + y^2}}$.

σ_{xy} soha $x^2 + y^2 \leq 1$ doiradan iborat.

U holda

$$\begin{aligned} \iint_{\sigma_{xy}} (x^2 + y^2) \sqrt{1 + \frac{x^2}{x^2 + y^2} + \frac{y^2}{x^2 + y^2}} dx dy &= \sqrt{2} \iint_{\sigma_{xy}} (x^2 + y^2) dx dy = \\ &= \sqrt{2} \iint_{\sigma_{xy}} (x^2 + y^2) dx dy = 4\sqrt{2} \int_0^{\frac{\pi}{2}} d\varphi \int_0^1 r^3 dr = \sqrt{2} \int_0^{\frac{\pi}{2}} d\varphi = \frac{\pi\sqrt{2}}{2}. \end{aligned}$$

3) Hosilalarni topamiz: $z'_x = \frac{-x}{\sqrt{9-x^2-y^2}}$, $z'_y = \frac{-y}{\sqrt{9-x^2-y^2}}$.

Bundan

$$\iint_{\sigma_{xy}} x^2 y^2 \sqrt{1 + \frac{x^2}{9-x^2-y^2} + \frac{y^2}{9-x^2-y^2}} dx dy = 3 \iint_{\sigma_{xy}} \frac{x^2 y^2 dx dy}{\sqrt{9-x^2-y^2}}.$$

Sferaning Oxy tekislikdagi proeksiyasi $x^2 + y^2 \leq 9$ doiradan iborat.

Qutb koordinatalariga o'tib, topamiz:

$$\begin{aligned} 3 \iint_{\sigma_{xy}} \frac{x^2 y^2 dx dy}{\sqrt{9-x^2-y^2}} &= 3 \int_0^{2\pi} \sin^2 \varphi \cos^2 \varphi d\varphi \int_0^3 \frac{r^5 dr}{\sqrt{9-r^2}} = \left| \begin{array}{l} 9-r^2 = t^2, \\ rdr = -tdt \end{array} \right| = \\ &= -\frac{3}{4} \int_0^{2\pi} (1 - \cos^2 2\varphi) d\varphi \int_3^0 (9-t^2)^2 dt = -\frac{3}{4} \int_0^{2\pi} \left(1 - \frac{1 + \cos 4\varphi}{2}\right) d\varphi \int_3^0 (81 - 18t^2 + t^4) dt = \\ &= -\frac{3}{4} \cdot \left(\frac{1}{2}\varphi - \frac{1}{8}\sin 2\varphi\right) \Big|_0^{2\pi} \cdot \left(81t - 6t^3 + \frac{t^5}{5}\right) \Big|_3^0 = \frac{282\pi}{5}. \quad \odot \end{aligned}$$

2.4.3. σ silliq sirt berilgan bo'lsin. Sirtning ixtiyoriy M nuqtasi orqali $\vec{n}(M)$ vektor o'tkazamiz. M nuqtadan o'tuvchi va sirtning chegaralari bilan umumiy nuqtaga ega bo'lmagan yopiq kontur olamiz. M nuqtani $\vec{n}(M)$ vektor bilan birga shu kontur bo'ylab \vec{n} vektor σ sirtga doim normal bo'ladigan qilib uzluksiz ko'chiramiz. Bunda M nuqta boshlang'ich holatiga normalning berilgan yo'nalishi bilan qaytsa bu sirtga *ikki tomonli* sirt deyiladi. Agar M nuqta boshlang'ich holatiga normalning berilgan yo'nalishiga qarama-qarshi yo'nalishi bilan qaytsa, bunday sirt *bir tomonli* sirt deb ataladi.

Agar σ sirt yopiq bo'lsa va $V \subset R^3$ jismni chegaralasa, u holda sirtning *musbat* yoki *tashqi tomoni* deb uning normal vektorlar V jismdan tashqariga yo'nalgan tomoniga, *manfiy* yoki *ichki tomoni* deb esa normal vektorlar V jismga qarab yo'nalgan tomoniga aytiladi.

Sirtning ma'lum tomonini tanlashga sirtning *oriyentatsiyalash* deyiladi. Agar sirtning tomoni tanlangan bo'lsa, u holda sirt *oriyentirlangan* deyiladi.

Ikki tomonli silliq (yoki bo'lakli silliq) $\sigma \subset R^3$ sirtida $\vec{n} = \{\cos\alpha; \cos\beta; \cos\gamma\}$ yo'nalish bilan xarakterlanuvchi σ^+ tomon tanlangan bo'lib, bu sirtida $R(x, y, z)$ funksiya aniqlangan bo'lsin.

σ sirtning ixtiyoriy ravishda o'tkazilgan egri chiziqlar to'ri bilan yuzalari $\Delta\sigma_1, \Delta\sigma_2, \dots, \Delta\sigma_n$ bo'lgan n ta σ_i bo'lakka bo'lamiz. Bu bo'laklarning Oxy tekislikdagi mos proyeksiyalarining yuzalarini $\Delta S_1, \Delta S_2, \dots, \Delta S_n$ bilan belgilaymiz. Har bir σ_i sirtida ixtiyoriy $M(x_i; y_i; z_i)$ nuqtani tanlaymiz, $R(x, y, z)$ funksiyaning bu nuqtadagi qiymati $R(x_i, y_i, z_i)$ ni hisoblab, uni ΔS_i ga ko'paytiramiz va barcha bunday ko'paytmalarning yig'indisini tuzamiz:

$$\sum_{i=1}^n R(x_i, y_i, z_i) \Delta S_i \quad (4.4)$$

Agar (4.4) integral yig'indining $\max d_i \rightarrow 0$ ($d_i = \Delta\sigma_i$ yuzaning diametri) dagi chekli limiti σ sirtning bo'laklarga bo'linish usuliga va bu bo'laklarda $M_i(x_i; y_i; z_i)$ nuqtani tanlash usuliga bog'liq bo'lmagan holda mavjud bo'lsa, bu limitga $R(x, y, z)$ funksiyaning σ sirt bo'yicha ikkinchi tur sirt integrali (yoki σ sirtida x va y koordinatalar bo'yicha integrali) deyiladi va $\iint_{\sigma} R(x, y, z) dx dy$ bilan belgilanadi:

$$\iint_{\sigma} R(x, y, z) dx dy = \lim_{\max d_i \rightarrow 0} \sum_{i=1}^n R(x_i, y_i, z_i) \Delta S_i.$$

$P(x, y, z)$ va $Q(x, y, z)$ funksiyalarning σ sirt bo'yicha ikkinchi tur sirt integrallari $\iint_{\sigma} P(x, y, z) dy dz$ va $\iint_{\sigma} Q(x, y, z) dx dz$ ham shu kabi ta'riflanadi.

2-teorema (*funksiya integrallanuvchi bo'lishining etarli sharti*). Agar $R(x, y, z)$ funksiya σ silliq sirtga uzluksiz bo'lsa, u holda u shu sirtida integrallanuvchi bo'ladi.

Agar σ sirt bo'yicha har uchchala ikkinchi tur sirt integrallari mavjud bo'lsa, u holda

$$\int_{\sigma} P(x, y, z) dy dz + Q(x, y, z) dx dz + R(x, y, z) dx dy \quad (4.5)$$

yig'indiga σ sirt bo'yicha umumiy ikkinchi tur sirt integrali deyiladi.

Ikkinchi tur sirt integrali ta'rifidan quyidagi tasdiqlar bevosita kelib chiqadi:

1. Agar sirt tomoni almashtirilsa (sirtning oriyentatsiyasi o'zgartirilsa) ikkinchi tur sirt integrali ishorasini o'zgartiradi.

2. Agar σ sirt yasovchilari Oz (Oy , Ox) o'qqa parallel bo'lgan silindrik sirt bo'lsa, $\iint_{\sigma} R(x, y, z) dx dy = 0$ ($\iint_{\sigma} Q(x, y, z) dx dz = 0$, $\iint_{\sigma} P(x, y, z) dy dz = 0$) bo'ladi.

3. Ikkinchi tur sirt integrali birinchi tur sirt integrali bo'ysunadigan boshqa xossalarga bo'ysunadi.

R^3 fazoda V jism berilgan bo'lib, bu jismni o'rab turgan σ silliq sirt $R(x, y, z)$ funksiya aniqlangan bo'lsin. Oxy tekislikka parallel bo'lgan tekislik bilan V ni ikkita qismga ajratamiz: $V = V_1 \cup V_2$. Bunda uni o'rab turgan σ sirt σ_1 va σ_2 sirtlarga ajraladi.

Ushbu

$$\iint_{\sigma_1} R(x, y, z) dx dy + \iint_{\sigma_2} R(x, y, z) dx dy \quad (4.6)$$

Integralga $R(x, y, z)$ funksiyaning yopiq sirt bo'yicha ikkinchi tur sirt integrali deyiladi $\oiint_{\sigma} R(x, y, z) dx dy$ bilan belgilanadi. Bunda birinchi integral σ_1 sirtning ustki tomoni, ikkinchi integral σ_2 sirtning pastki tomoni bo'yicha olinadi.

2.4.4. Oriyentirlangan σ sirt $z = z(x, y)$ tenglama bilan berilgan, ya'ni

$$\sigma = \{(x, y, z) \in R^3 : z = z(x, y), (x, y) \in \sigma_{xy}\}$$

bo'lsin, bu yerda σ_{xy} – σ sirtning Oxy tekislikdagi proyeksiyasi.

Agar $z(x, y)$, $z'_x(x, y)$, $z'_y(x, y)$ funksiyalar σ_{xy} sohada uzluksiz va $R(x, y, z)$ funksiya σ sirtida uzluksiz bo'lsa

$$\iint_{\sigma} R(x, y, z) dx dy = \iint_{\sigma_{xy}} R(x, y, z(x, y)) dx dy \quad (4.7)$$

ikkinchi tur sirt integralini hisoblash formulasini hosil qilinadi.

Agar sirtning oriyentatsiyasi o'zgartirilsa, (4.7) tenglikning o'ng tomonidagi integral oldiga manfiy ishora qo'yiladi. Bunda sirt normalining yo'naltiruvchi kosinuslarida ildiz oldida ma'lum bir ishorani tanlash orqali sirt oriyentatsiyalanadi. Masalan, ildiz oldida musbat ishora olinsa $\cos \gamma > 0$ bo'ladi. Bunda sirt normali oz o'q bilan o'tkir burchak tashkil qiladi va σ sirtning yuqori tomoni tanlanadi.

Quyidagi integrallash formulalari shu kabi hosil qilinadi:

$$\iint_{\sigma} Q(x, y, z) dx dz = \iint_{\sigma_{xz}} Q(x, y(x, z), z) dx dz, \quad (4.8)$$

$$\iint_{\sigma} P(x, y, z) dydz = \iint_{\sigma_{yz}} P(x(y, z), y, z) dydz, \quad (4.9)$$

bu yerda σ sirt mos ravishda $y = y(x, z)$ va $x = x(y, z)$ tenglama bilan berilgan, σ_{xz} , σ_{yz} – σ sirtning Oxz va Oyz tekisliklardagi proyeksiyalari.

Agar σ sirt uchala koordinatalar tekisligida proeksiyalanuvchi bo'lsa, u holda σ sirt bo'yicha umumiy ikkinchi tur sirt integral (4.7) - (4.9) tengliklar yig'indisidan iborat bo'ladi. Murakkabroq hollarda σ sirt bir nechta tayin xossalarga ega bo'lgan sirtlarga bo'linadi va σ sirt bo'yicha umumiy integral bu sirtlar bo'yicha integrallar yig'indisiga teng bo'ladi.

Birinchi va ikkinchi tur sirt integrallari

$$\begin{aligned} & \iint_{\sigma} P(x, y, z) dydz + Q(x, y, z) dzdx + R(x, y, z) dxdy = \\ & = \iint_{\sigma} (P(x, y, z) \cos \alpha + Q(x, y, z) \cos \beta + R(x, y, z) \cos \gamma) d\sigma \end{aligned} \quad (4.10)$$

bog'lanishga ega, bu yerda $\cos \alpha$, $\cos \beta$, $\cos \gamma$ – σ sirt \vec{n} normal vektorining yo'naltiruvchi kosinuslari.

3-teorema. Agar V sohada $P(x, y, z)$, $Q(x, y, z)$, $R(x, y, z)$ funksiyalar o'zlarining birinchi tartibli xususiy hosilalari bilan birgalikda uzluksiz bo'lsa, u holda

$$\iiint_V \left(\frac{\partial P}{\partial x} + \frac{\partial Q}{\partial y} + \frac{\partial R}{\partial z} \right) dxdydz = \iint_{\sigma} P dydz + Q dx dz + R dx dy \quad (4.11)$$

bo'ladi, bu yerda σ – V sohani chegaralovchi yopiq silliq sirt.

(4.11) tenglikka *Ostrogradskiy-Gauss formulasi* deyiladi.

4-teorema. Agar $P(x, y, z)$, $Q(x, y, z)$, $R(x, y, z)$ funksiyalar o'zlarining birinchi tartibli xususiy hosilalari bilan birgalikda oriyentirlangan σ sirtida uzluksiz bo'lsa, u holda

$$\begin{aligned} & \oint_L P(x, y, z) dx + Q(x, y, z) dy + R(x, y, z) dz = \\ & = \iint_{\sigma} \left(\frac{\partial Q}{\partial x} - \frac{\partial P}{\partial y} \right) dxdy + \left(\frac{\partial R}{\partial y} - \frac{\partial Q}{\partial z} \right) dydz + \left(\frac{\partial P}{\partial z} - \frac{\partial R}{\partial x} \right) dxdz \end{aligned} \quad (4.12)$$

bo'ladi, bu yerda L – σ sirtning chegarasi va L egri chiziq bo'yicha integral musbat yo'nalishda olingan.

Bu tenglikka *Stoks formulasi* deyiladi.

Agar $\frac{\partial Q}{\partial x} = \frac{\partial P}{\partial y}$, $\frac{\partial R}{\partial y} = \frac{\partial Q}{\partial z}$, $\frac{\partial P}{\partial z} = \frac{\partial R}{\partial x}$ shart bajarilsa $\oint_L P dx + Q dy + R dz = 0$

bo'ladi. Bunda egri chizikli integral integrallash yo'liga bog'liq bo'lmaydi.

2-misol. Ikkinchi tur sirt integrallarini hisoblang:

1) $\iint_{\sigma} xz dx dy + xy dy dz + yz dx dz$, bu yerda $\sigma: x + y + z - 1 = 0, x = 0, y = 0, z = 0$

tekisliklar bilan chegaralangan tetraedrning tashqi sirti;

2) $\iint_{\sigma} x^2 y^2 z dx dy$ integralni hisoblang, bu yerda $\sigma: x^2 + y^2 + z^2 = 4$ sferaning yuqori sirti;

3) $\iint_{\sigma} x dy dz$, bu yerda $\sigma: x = y^2 + z^2$ paraboloidning $x = 2$ tekislik bilan kesilgan tashqi sirti.

⊕ 1) Tetraedrning sirti to'rtta ABC, AOC, ABO, BOC uchburchakdan tashkil topadi (14-shakl). Shu sababli har uchala integralni har bir uchburchakda hisoblaymiz.

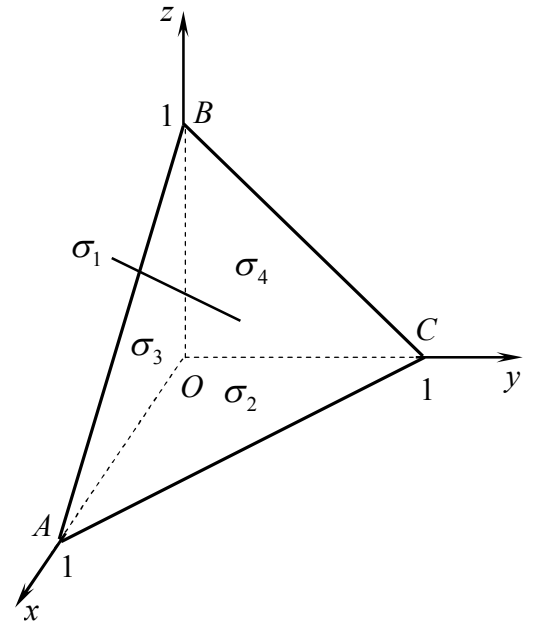

14-shakl.

ABC uchburchakda (σ_1 sirtida):

$$I_1 = \iint_{\sigma_1} xz dx dy + \iint_{\sigma_1} xy dy dz + \iint_{\sigma_1} yz dx dz = \int_0^1 x dx \int_0^{1-x} (1-x-y) dy + \int_0^1 y dy \int_0^{1-y} (1-y-z) dz + \int_0^1 z dz \int_0^{1-z} (1-x-z) dx = \frac{1}{2} \int_0^1 x(1-x)^2 + \frac{1}{2} \int_0^1 y(1-y)^2 dy + \frac{1}{2} \int_0^1 z(1-z)^2 dz = \frac{1}{8}.$$

AOC uchburchakda (σ_2 sirtida): $z = 0$ va $\sigma_2 \perp \sigma_3, \sigma_2 \perp \sigma_4$. Bundan

$$I_2 = \iint_{\sigma_2} xz dx dy + \iint_{\sigma_2} xy dy dz + \iint_{\sigma_2} yz dx dz = 0.$$

ABO uchburchakda (σ_3 sirtida): $y = 0$ va $\sigma_3 \perp \sigma_2, \sigma_3 \perp \sigma_4$. Bundan

$$I_3 = \iint_{\sigma_3} xz dx dy + \iint_{\sigma_3} xy dy dz + \iint_{\sigma_3} yz dx dz = 0.$$

BOC uchburchakda (σ_4 sirtida): $x = 0$ va $\sigma_4 \perp \sigma_2, \sigma_4 \perp \sigma_3$. Bundan

$$I_4 = \iint_{\sigma_4} xz dx dy + \iint_{\sigma_4} xy dy dz + \iint_{\sigma_4} yz dx dz = 0.$$

Demak,

$$\iint_{\sigma} xz dx dy + xy dy dz + yz dx dz = \frac{1}{8} + 0 + 0 + 0 = \frac{1}{8}.$$

2) Sferaning Oxy tekislikdagi σ_{xy} proyeksiyasi $x^2 + y^2 \leq 4$ doiradan iborat bo'ladi. Sfera yuqori tomoni $z = \sqrt{4 - x^2 - y^2}$ tenglama bilan aniqlanadi.

U holda

$$\begin{aligned} \iint_{\sigma_{xy}} x^2 y^2 \sqrt{4-x^2-y^2} dx dy &= \iint_{\sigma_{xy}} r^2 \cos^2 \varphi \cdot r^2 \sin^2 \varphi \sqrt{4-r^2} r dr d\varphi = \\ &= 4 \int_0^{\frac{\pi}{2}} \cos^2 \varphi \sin^2 \varphi d\varphi \int_0^2 r^5 \sqrt{4-r^2} dr = (t^2 = 4-r^2 \text{ belgilash kiritamiz}) = \\ &= 4 \int_0^{\frac{\pi}{2}} \cos^2 \varphi \sin^2 \varphi d\varphi \int_0^2 (4-t^2)^2 t^2 dt = \int_0^{\frac{\pi}{2}} \sin^2 2\varphi \left(16 \frac{t^3}{3} - 8 \frac{t^5}{5} + \frac{t^7}{7} \right) \Big|_0^2 d\varphi = \\ &= \frac{1024}{105} \int_0^{\frac{\pi}{2}} \sin^2 2\varphi d\varphi = \frac{512}{105} \int_0^{\frac{\pi}{2}} (1 - \cos 4\varphi) d\varphi = \\ &= \frac{512}{105} \left(\varphi - \frac{\sin 4\varphi}{4} \right) \Big|_0^{\frac{\pi}{2}} = \frac{256\pi}{105}. \end{aligned}$$

3) Berilgan sirtning Oyz tekislikdagi σ_{yz} proyeksiyasi $y^2 + z^2 \leq 2$ doiradan iborat bo'ladi (15-shakl).

U holda

$$\begin{aligned} \iint_{\sigma} x dy dz &= \iint_{\sigma_{yz}} (y^2 + z^2) dy dz = \iint_{\sigma_{yz}} r^2 r dr d\varphi = \\ &= \int_0^{2\pi} d\varphi \int_0^{\sqrt{2}} r^3 dr = \int_0^{2\pi} \frac{r^4}{4} \Big|_0^{\sqrt{2}} d\varphi = \int_0^{2\pi} d\varphi = 2\pi. \quad \odot \end{aligned}$$

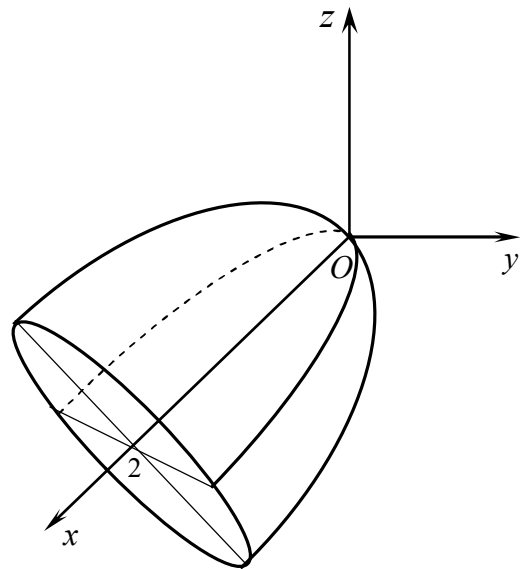

15-shakl.

3-misol. $\iint_{\sigma} z \cos \gamma d\sigma$ integralni

hisoblang, bu yerda $\sigma: x^2 + y^2 + z^2 = 1$ sferaning yuqori sirti.

☉ Integralni (4.10) formula bilan hisoblaymiz:

$$\begin{aligned} \iint_{\sigma} z \cos \gamma d\sigma &= \iint_{\sigma_{xy}} z dx dy = \iint_{\sigma_{xy}} \sqrt{1-x^2-y^2} dx dy = \\ &= \int_0^{2\pi} d\varphi \int_0^1 \sqrt{1-r^2} r dr = -\frac{1}{3} \int_0^{2\pi} (1-r^2)^{\frac{3}{2}} \Big|_0^1 d\varphi = \frac{1}{3} \int_0^{2\pi} d\varphi = \frac{2\pi}{3}. \quad \odot \end{aligned}$$

4-misol. $\iiint_{\sigma} x dy dz + y dz dx + z dx dy$ integralni hisoblang, bu yerda $\sigma: x=0,$

$y=0, z=0, x=1, y=1, z=1$ tekisliklar bilan chegaralangan kubning tashqi tomoni.

☉ Integralni Ostrogradskiy-Gauss formulasi bilan hisoblaymiz:

$$\iiint_{\sigma} x dy dz + y dz dx + z dx dy = \iiint_V (1+1+1) dx dy dz = 3 \iiint_V dx dy dz = 3 \int_0^1 dx \int_0^1 dy \int_0^1 dz = 3. \quad \odot$$

5-misol. $\oint_L x^2 y^3 dx + dy + z dz$ integralni hisoblang, bu yerda

$L: x^2 + y^2 = 0, z = 0$ sirtlar bilan chegaralangan aylana.

☉ Integralni Stoks formulasi bilan hisoblaymiz:

$$I = \oint_L x^2 y^3 dx + dy + z dz = \iint_{\sigma} (0 - 3x^2 y^2) dx dy + (0 - 0) dy dz + (0 - 0) dx dz = -3 \iint_{\sigma} x^2 y^2 dx dy,$$

bu yerda $\sigma: z = +\sqrt{R^2 - x^2 - y^2}$ yarim sfera sirti.

U holda

$$\begin{aligned} I &= -3 \iint_{\sigma} x^2 y^2 dx dy = -3 \iint_{\sigma_{xy}} x^2 y^2 dx dy = -3 \iint_{\sigma_{xy}} r^5 \sin^2 \varphi \cos^2 \varphi dr d\varphi = \\ &= -3 \int_0^{2\pi} \sin^2 \varphi \cos^2 \varphi d\varphi \cdot \int_0^R r^5 dr = -\frac{3}{6} R^6 \int_0^{2\pi} \frac{1}{4} \sin^2 2\varphi d\varphi = \\ &= -\frac{R^6}{8} \cdot \frac{1}{2} \int_0^{2\pi} (1 - \cos 4\varphi) d\varphi = -\frac{1}{16} \cdot \varphi \Big|_0^{2\pi} = -\frac{\pi R^6}{8}. \quad \ominus \end{aligned}$$

2.4.5. Sirt yuzasi. $z = z(x, y)$ tenglama bilan berilgan sirt yuzasi

$$S = \iint_{\sigma} d\sigma \text{ yoki} \quad (4.13)$$

formula bilan topiladi (birinchi tur sirt integralining *geometrik ma'nosi*).

Sirt massasi. σ sirtning massasi

$$m = \iint_{\sigma} \gamma(x, y, z) d\sigma \quad (4.14)$$

formula bilan topiladi, bu yerda $\gamma - \sigma$ sirtning sirtiy zichligi (birinchi tur sirt integralining *mexanik ma'nosi*).

Sirtning statistik momentlari, og'irlik markazi. AB material egri chiziqning Ox, Oy o'qlarga nisbatan statistik momentlari va og'irlik markazining koordinatalari

$$S_{xy} = \iint_{\sigma} z\gamma(x, y, z) d\sigma, \quad S_{yz} = \iint_{\sigma} x\gamma(x, y, z) d\sigma, \quad S_{xz} = \iint_{\sigma} y\gamma(x, y, z) d\sigma, \quad (4.15)$$

$$x_c = \frac{S_{yz}}{m}, \quad y_c = \frac{S_{xz}}{m}, \quad z_c = \frac{S_{xy}}{m} \quad (4.16)$$

formular bilan topiladi.

Inersiya momentlari. AB material egri chiziqning Ox, Oy o'qlarga va koordinata boshiga nisbatan inersiya momentlari mos ravishda quyidagilarga teng:

$$\begin{aligned} I_x &= \iint_{\sigma} (y^2 + z^2) \gamma(x, y, z) d\sigma, \quad I_y = \iint_{\sigma} (x^2 + z^2) \gamma(x, y, z) d\sigma, \\ I_z &= \iint_{\sigma} (y^2 + x^2) \gamma(x, y, z) d\sigma, \quad I_0 = \iint_{\sigma} (x^2 + y^2 + z^2) \gamma(x, y, z) d\sigma, \end{aligned} \quad (4.17)$$

Jismning hajmi. Quyidan tenglamasi $z = z_1(x, y)$ bo'lgan σ_1 silliq sirt bilan, yuqoridan tenglamasi $z = z_2(x, y)$ bo'lgan σ_2 silliq sirt bilan yon tomondan yasovchilari oz o'qqa parallel bo'lgan σ_3 silindrik sirt bilan chegaralangan jismning hajmi

$$V = \frac{1}{3} \iiint_{\sigma} xdydz + ydxdz + zdx dy \quad (4.18)$$

integral bilan hisoblanadi, bu yerda $\sigma = \sigma_1 + \sigma_2 + \sigma_3$.

6-misol. $z = x$ tekislikning $x + y = 1$, $x = 0$, $y = 0$ tekisliklar bilan chegaralangan qismining yuzasini toping (16-shakl).

☉ $z = x$ dan $z'_x = 1$, $z'_y = 0$. Sirt yuzasini (4.13) formula bilan topamiz:

$$\begin{aligned} S &= \iint_{\sigma} d\sigma = \iint_{\sigma_{xy}} \sqrt{1 + z'^2_x + z'^2_y} dx dy = \sqrt{2} \int_0^1 dx \int_0^{1-x} dy = \\ &= \sqrt{2} \int_0^1 (1-x) dx = \sqrt{2} \left(x - \frac{x^2}{2} \right) \Big|_0^1 = \frac{\sqrt{2}}{2}. \end{aligned} \quad \text{☉}$$

7-misol. Bir jinsli $z = x^2 + y^2$ ($0 \leq z \leq 1$) parabolik qobiqning massasini va og'irlik markazining koordinatalarini toping.

☉ Bir jinsli qobiq uchun (4.14) formula $m = \iint_{\sigma} d\sigma$ ko'rinishni oladi.

U holda

$$m = \iint_{\sigma_{xy}} \sqrt{1 + z'^2_x + z'^2_y} dx dy = \iint_{\sigma_{xy}} \sqrt{1 + 4(x^2 + y^2)} dx dy,$$

bu yerda $\sigma_{xy} : x^2 + y^2 \leq 1$ doira.

Bundan

$$m = \int_0^{2\pi} d\varphi \int_0^1 \sqrt{1 + 4r^2} r dr = \frac{\pi}{6} (1 + 4r^2)^{\frac{3}{2}} \Big|_0^1 = \frac{\pi}{6} (5\sqrt{5} - 1).$$

Simmetriyaga ko'ra $x_c = y_c = 0$.

$$\begin{aligned} z_c &= \frac{1}{m} \iint_{\sigma} z d\sigma = \frac{1}{m} \int_0^{2\pi} d\varphi \int_0^1 r^2 \sqrt{1 + 4r^2} dr = (t^2 = 1 + 4r^2 \text{ belgilash kiritamiz}) = \\ &= \frac{1}{m} \frac{\pi}{8} \int_1^{\sqrt{5}} (t^4 - t^2) dt = \frac{5(\sqrt{5} + 1)}{2(5\sqrt{5} - 1)}. \end{aligned} \quad \text{☉}$$

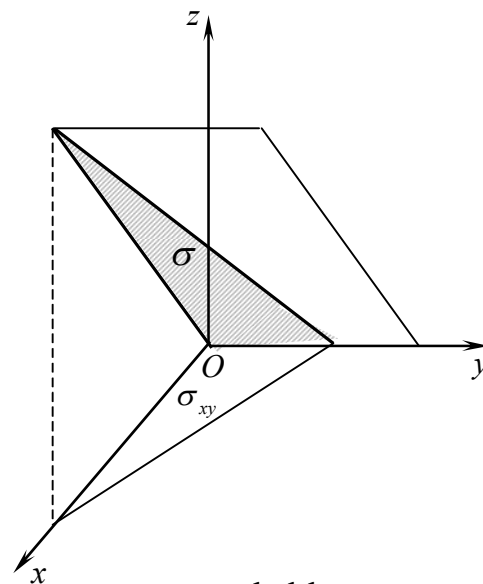

16-shakl.

Mashqlar

2.4.1. Birinchi tur sirt integrallarini hisoblang:

- 1) $\iint_{\sigma} (6x + 4y + 3z) d\sigma$, bu yerda $\sigma: x + 2y + 3z - 6 = 0$ tekislikning birinchi oktantdagi qismi;
- 2) $\iint_{\sigma} xy^2 z d\sigma$, bu yerda $\sigma: x + y + z - 1 = 0$ tekislikning birinchi oktantdagi qismi;
- 3) $\iint_{\sigma} \sqrt{x^2 + y^2} d\sigma$, bu yerda $\sigma: z^2 = x^2 + y^2$ konus sirtning $z = 0$ va $z = 1$ tekisliklar orasidagi qismi;
- 4) $\iint_{\sigma} \sqrt{1 + 4x^2 + 4y^2} d\sigma$, bu yerda $\sigma: z = 1 - x^2 - y^2$ paraboloidning $z = 0$ tekislik bilan kesilgan qismi;
- 5) $\iint_{\sigma} \sqrt{4 - x^2 - y^2} d\sigma$, bu yerda $\sigma: z = \sqrt{4 - x^2 - y^2}$ yarim sfera;
- 6) $\iint_{\sigma} (x + y + z) d\sigma$, bu yerda $\sigma: x^2 + y^2 + z^2 = R^2$ sferaning birinchi oktantdagi qismi.

2.4.2. Ikkinchi tur sirt integrallarini hisoblang:

- 1) $\iint_{\sigma} x dy dz + y dz dx + z dx dy$, bu yerda $\sigma: x = 0, y = 0, z = 0, x = 1, y = 1, z = 1$ tekisliklar bilan chegaralangan kubning tashqi tomoni;
- 2) $\iint_{\sigma} x dy dz + y dz dx + z dx dy$, bu yerda $\sigma: x + y + z = 1$ tekislikning koordinata tekisliklari bilan chegaralangan qismining tashqi tomoni;
- 3) $\iint_{\sigma} xy z dx dy$, bu yerda $\sigma: x^2 + y^2 + z^2 = 9$ ($z \geq 0$) yarim sferaning tashqi tomoni;
- 4) $\iint_{\sigma} \frac{dx dy}{z}$, bu yerda $\sigma: x^2 + y^2 + z^2 = a^2$ sferaning tashqi tomoni;
- 5) $\iint_{\sigma} z dx dy + x dy dz$, bu yerda $\sigma: x^2 + y^2 + z^2 = 1$ sfera pastki qismining tashqi tomoni;
- 6) $\iint_{\sigma} x^2 dy dz$, bu yerda $\sigma: z = \frac{H}{R^2}(x^2 + y^2), x = 0, y = 0, z = H$ paraboloid sirti qismining tashqi tomoni.

2.4.3. Integrallarini Ostrogradskiy-Gauss formulasi bilan hisoblang:

- 1) $\iiint_{\sigma} (x \cos \alpha + y \cos \beta + z \cos \gamma) d\sigma$, bu yerda $\sigma: \frac{x^2}{a^2} + \frac{y^2}{b^2} + \frac{z^2}{c^2} = 1$ ellipsoid sirti;

- 2) $\iint_{\sigma} xdydz + ydzdx + zdx dy$, bu yerda $\sigma: x^2 + y^2 = R^2, -h \leq z \leq h$ silindr sirti;
- 3) $\iint_{\sigma} x^2 dydz + y^2 dzdx + z^2 dxdy$, bu yerda $\sigma: \frac{x^2}{a^2} + \frac{y^2}{a^2} - \frac{z^2}{b^2} = 0 (0 < z < b)$ konus sirti;
- 4) $\iint_{\sigma} x^3 dydz + y^3 dzdx + z^3 dxdy$, bu yerda $\sigma: x^2 + y^2 + z^2 = R^2$ sferaning tashqi tomoni.

2.4.4. Integrallarini Stoks formulasi bilan hisoblang:

- 1) $\oint_L x^2 y dx + dy + z dz$, bu yerda $L: x^2 + y^2 = R^2, z = 0$ aylana;
- 2) $\oint_L x^2 y^3 dx + dy - z dz$, bu yerda $L: x^2 + y^2 = 4, z = 0$ aylana.

2.4.5. Berilgan tekisliklarning birinchi oktantda yotgan qismining yuzasini toping: 1) $6x + 3y + 2z = 12$; 2) $10x + 5y + 4z = 20$.

2.4.6. $4z = x^2 + y^2$ paraboloidning $y^2 = z$ silindr va $z = 3$ tekislik bilan kesilgan qismining yuzasini toping.

2.4.7. Sirtiy zichligi $\gamma = \frac{z}{R}$ ga teng bo'lgan $z = \sqrt{R^2 - x^2 - y^2}$ yarim sferaning massasini toping.

2.4.8. Sirtiy zichligi $\gamma = \sqrt{x^2 + y^2}$ ga teng bo'lgan $x^2 + y^2 + z^2 = R^2$ shar qobig'ining massasini toping.

2.4.9. $z^2 = x^2 + y^2 (0 \leq z \leq h)$ konus yon sirtining Oz oqqa nisbatan inersiya momentini toping.

2.5. MAYDONLAR NAZARIYASI ELEMENTLARI

Yo'nalish bo'yicha hosila. Skalyar maydon gradiyenti.
Vektor maydon oqimi. Vektor maydon divergensiyasi.
Vektor maydon sirkulatsiyasi. Vektor maydon uyurmasi

📌 2.5.1. Fazoning har bir M nuqtasida u skalyar kattalikning son qiymati aniqlangan qismiga (yoki butun fazoga) *skalyar maydon* deyiladi.

Agar u kattalik t vaqtga bog'liq bo'lmasa, bu kattalik bilan aniqlangan maydonga *statsionar maydon*, aks holda *nostatsionar maydon* deyiladi.

Stasionar maydonda u kattalik faqat M nuqtaning fazodagi o'rniga bog'liq bo'ladi va $u = u(M)$ kabi belgilanadi. Bunda $u = u(M)$ funksiyaga *maydon funksiyasi* deyiladi. R^3 fazoning $Oxyz$ koordinatalar sistemasida $u = u(x, y, z)$ bo'ladi.

⇒ Skalyar maydonning geometrik tasviri sath sirtlari hisoblanadi. Fazoning $u = u(x, y, z)$ maydon funksiyasi o'zgarmas C qiymatga teng bo'ladigan barcha nuqtalari to'plamiga skalyar maydonning *sath sirti* deyiladi. Sath sirti $u(x, y, z) = C$ tenglama bilan aniqlanadi.

☑ Tekislikning har bir M nuqtasida z skalyar kattalik aniqlangan qismiga (yoki butun tekislikka) *yassi skalyar maydon* deyiladi. Yassi skalyar maydon funksiyasi $z = f(x, y)$ ko'rinishida bo'ladi. Yassi skalyar maydonning geometrik tasviri sath chizig'i hisoblanadi. *Sath chizig'i* $f(x, y) = C$ tenglama bilan aniqlanadi.

Skalyar maydonning $u = u(x, y, z)$ differensiyallanuvchi funksiyasi berilgan bo'lsin. $M(x; y; z)$ bu maydonning biror nuqtasi, l shu nuqtadan $\vec{l}^0 = \cos \alpha \cdot \vec{i} + \cos \beta \cdot \vec{j} + \cos \gamma \cdot \vec{k}$ birlik vektor yo'nalishida chiquvchi nur bo'lsin, bu yerda α, β, γ – l nurning Ox, Oy, Oz o'qlar bilan tashkil qilgan burchaklari.

$$\Delta_l u = u(x + \Delta x, y + \Delta y, z + \Delta z) - u(x, y, z)$$

ayirmaga bu funksiyaning l yo'nalish bo'yicha orttirmasi deyiladi.

☑ $u = u(x, y, z)$ funksiyaning $M(x; y; z)$ nuqtadagi l yo'nalish bo'yicha *hosilasi* deb

$$\frac{\partial u}{\partial l} = \lim_{\Delta l \rightarrow 0} \frac{\Delta_l u}{\Delta l}$$

limitga aytiladi, bu yerda $\Delta l = M_1$ va M nuqtalar orasidagi masofa.

l yo'nalish bo'yicha hosila u funksiyaning shu yo'nalish bo'yicha o'zgarishini xarakterlaydi. Bunda $\frac{\partial u}{\partial l}$ ning ishorasi u funksiyaning o'sishi

yoki kamayishini belgilasa, $\left| \frac{\partial u}{\partial l} \right|$ bu o'zgarishning tezligini belgilaydi.

⇒ Agar $u = u(x, y, z)$ funksiya $M(x; y; z)$ nuqtada differensiyallanuvchi bo'lsa, u holda uning bu nuqtadagi l yo'nalish bo'yicha hosilasi

$$\frac{\partial u}{\partial l} = \frac{\partial u}{\partial x} \cos \alpha + \frac{\partial u}{\partial y} \cos \beta + \frac{\partial u}{\partial z} \cos \gamma \quad (5.1)$$

tenglik bilan aniqlanadi, bu yerda $\cos \alpha, \cos \beta, \cos \gamma$ – \vec{l} vektorning

yo'naltiruvchi kosinuslari.

Agar \vec{l} yo'nalish koordinatalar o'qining yo'nalishlaridan biri bilan bir xil bo'lsa u funksiyaning bu yo'nalish bo'yicha hosilasi tegishli xususiy hosilaga teng bo'ladi. Masalan, $\vec{l} = \vec{i}$ da $\frac{\partial u}{\partial l} = \frac{\partial u}{\partial x}$.

u funksiyaning \vec{l} yo'nalishga teskari yo'nalish bo'yicha hosilasi uning \vec{l} yo'nalish bo'yicha hosilasiga teskari ishora bilan teng bo'ladi.

Yassi z maydonda

$$\frac{\partial z}{\partial l} = \frac{\partial z}{\partial x} \cos \alpha + \frac{\partial z}{\partial y} \sin \alpha \quad (5.2)$$

bo'ladi.

M_1 nuqta M nuqtaga biror egri chiziq bo'ylab intilayotgan bo'lsin. Agar bunda bu egri chiziqqa M nuqtada o'tkazilgan urinmaning yo'nalishi \vec{l} yo'nalish bilan bir xil bo'lsa, u holda (5.1) formula o'z kuchini saqlaydi.

1-misol. $u = 2x^3yz + x^2 + y^3 + z^3$ funksiyaning $M_0(1;-1;2)$ nuqtada $\vec{a} = \{2;-1;0\}$ vektor yo'nalishdagi hosilasini toping.

☉ $u = 2x^3yz + x^2 + y^3 + z^3$ funksiyaning xususiy hosilalarini topamiz:

$$\frac{\partial u}{\partial x} = 6x^2yz + 2x, \quad \frac{\partial u}{\partial y} = 2x^3z + 3y^2, \quad \frac{\partial u}{\partial z} = 2x^3y + 3z^2.$$

Bundan

$$\left. \frac{\partial u}{\partial x} \right|_{M_0} = -10, \quad \left. \frac{\partial u}{\partial y} \right|_{M_0} = 7, \quad \left. \frac{\partial u}{\partial z} \right|_{M_0} = 10.$$

$\vec{a} = \{2;-1;0\}$ vektorning yo'naltiruvchi kosinuslarini topamiz:

$$\cos \alpha = \frac{a_x}{|\vec{a}|} = \frac{2}{\sqrt{2^2 + (-1)^2 + 0}} = \frac{2}{\sqrt{5}}, \quad \cos \beta = \frac{a_y}{|\vec{a}|} = -\frac{1}{\sqrt{5}}, \quad \cos \gamma = \frac{a_z}{|\vec{a}|} = 0.$$

Xususiy hosilalar va yo'naltiruvchi kosinuslarning qiymatlarini (5.1) formulaga qo'yamiz:

$$\left. \frac{\partial u}{\partial l} \right|_{M_0} = -10 \cdot \frac{2}{\sqrt{5}} + 7 \cdot \left(-\frac{1}{\sqrt{5}} \right) + 10 \cdot 0 = -\frac{27\sqrt{5}}{5}. \quad \text{☉}$$

2-misol. $u = x^3 - 3xy^2 + yz$ funksiyaning $M_1(1;2;-1)$ nuqtada, shu nuqtadan $M_2(3;4;-2)$ nuqtaga tomon yo'nalishdagi hosilasini toping.

☉ $\overrightarrow{M_1M_2}$ vektorning yo'naltiruvchi kosinuslarini topamiz:

$$\overrightarrow{M_1M_2} = (3-1)\vec{i} + (4-2)\vec{j} + (-2-(-1))\vec{k} = 2\vec{i} + 2\vec{j} - \vec{k},$$

$$\vec{l}^0 = \frac{\overrightarrow{M_1 M_2}}{|\overrightarrow{M_1 M_2}|} = \frac{2\vec{i} + 2\vec{j} - \vec{k}}{\sqrt{2^2 + 2^2 + (-1)^2}} = \frac{2}{3}\vec{i} + \frac{2}{3}\vec{j} - \frac{1}{3}\vec{k},$$

$$\cos \alpha = \frac{2}{3}, \quad \cos \beta = \frac{2}{3}, \quad \cos \gamma = -\frac{1}{3}.$$

$u = x^3 - 3xy^2 + yz$ funksiya xususiy hosilalarining $M_1(1;2;-1)$ nuqtadagi qiymatlarini topamiz:

$$\left. \frac{\partial u}{\partial x} \right|_{M_1} = (3x^2 - 3y^2)|_{M_1} = -9, \quad \left. \frac{\partial u}{\partial y} \right|_{M_1} = (-6xy + z)|_{M_1} = -13, \quad \left. \frac{\partial u}{\partial z} \right|_{M_1} = y|_{M_1} = 2.$$

U holda

$$\left. \frac{\partial u}{\partial l} \right|_{M_1} = -9 \cdot \frac{2}{3} - 13 \cdot \frac{2}{3} + 2 \cdot \left(-\frac{1}{3}\right) = -\frac{46}{3}. \quad \ominus$$

3-misol. $u = \ln(xy + yz + zx)$ funksiyaning $M_0(0;1;1)$ nuqtada $x = \cos t$, $y = \sin t$, $z = 1$, $0 \leq t \leq 2\pi$ aylana yo'nalishdagi hosilasini toping.

☉ Aylananing vektor tenglamasini tuzamiz:

$$\vec{r}(t) = \cos t \cdot \vec{i} + \sin t \cdot \vec{j} + 1 \cdot \vec{k}.$$

Aylanaga o'tkazilgan urunmaning birlik vektorini topamiz:

$$\vec{r}^0 = \frac{d\vec{r}}{dt} = -\sin t \cdot \vec{i} + \cos t \cdot \vec{j}.$$

$M_0(0;1;1)$ nuqtada $t_0 = \frac{\pi}{2}$ bo'ladi. Bundan $\vec{r}^0|_{M_0} = -\sin \frac{\pi}{2} \cdot \vec{i} + \cos \frac{\pi}{2} \cdot \vec{j} = -1 \cdot \vec{i}$.

Aylanaga $M_0(0;1;1)$ nuqtada o'tkazilgan urunmaning yo'naltiruvchi kosinuslarini topamiz: $\cos \alpha = -1$, $\cos \beta = 0$, $\cos \gamma = 0$.

Xususiy hosilalarning $M_0(0;1;1)$ nuqtadagi qiymatlarini topamiz:

$$\left. \frac{\partial u}{\partial x} \right|_{M_0} = \frac{y+z}{xy+yz+zx}|_{M_0} = 2, \quad \left. \frac{\partial u}{\partial y} \right|_{M_0} = \frac{x+z}{xy+yz+zx}|_{M_0} = 1, \quad \left. \frac{\partial u}{\partial z} \right|_{M_0} = \frac{y+x}{xy+yz+zx}|_{M_0} = 1.$$

U holda

$$\left. \frac{\partial u}{\partial l} \right|_{M_0} = 2 \cdot (-1) + 1 \cdot 0 + 1 \cdot 0 = -2. \quad \ominus$$

4-misol. $z = \arctg(xy)$ funksiyaning $M_0(1;1)$ nuqtada $y = x^2$ parabolada yotuvchi, shu parabola yo'nalishdagi hosilasini toping (absissaning o'sish yo'nalishida).

☉ Parabola $M_0(1;1)$ nuqtada Ox o'q bilan α burchak tashkil qilsin.

U holda $\operatorname{tg} \alpha = y'(x)|_{x=1} = 2$ bo'ladi.

Bundan urunmaning yo‘naltiruvchi kosinuslarini topamiz:

$$\cos \alpha = \frac{1}{\sqrt{1 + \operatorname{tg}^2 \alpha}} = \frac{1}{\sqrt{5}}, \quad \sin \alpha = \frac{\operatorname{tg} \alpha}{\sqrt{1 + \operatorname{tg}^2 \alpha}} = \frac{2}{\sqrt{5}}.$$

Funksiya xususiy hosilalarining $M_0(1;1)$ nuqtadagi qiymatlarini topamiz:

$$\left. \frac{\partial z}{\partial x} \right|_{M_0} = \frac{y}{1 + x^2 y^2} \Big|_{M_0} = \frac{1}{2}, \quad \left. \frac{\partial u}{\partial y} \right|_{M_0} = \frac{x}{1 + x^2 y^2} \Big|_{M_0} = \frac{1}{2}.$$

U holda

$$\left. \frac{\partial u}{\partial l} \right|_{M_0} = \frac{1}{2} \cdot \frac{1}{\sqrt{5}} + \frac{1}{2} \cdot \frac{2}{\sqrt{5}} = \frac{3\sqrt{5}}{10}. \quad \ominus$$

☐ **2.5.2.** $u(x, y, z)$ skalyar maydonning $M(x; y; z)$ nuqtadagi *gradiyenti* deb

$$\operatorname{gradu} = \frac{\partial u}{\partial x} \vec{i} + \frac{\partial u}{\partial y} \vec{j} + \frac{\partial u}{\partial z} \vec{k} \quad (5.3)$$

vektorga aytiladi.

Bundan

$$\frac{\partial u}{\partial l} = \operatorname{gradu} \cdot \vec{l}^0. \quad (5.4)$$

⇒ $u(x, y, z)$ skalyar maydon gradiyenti bu maydon o‘zgarishning eng katta tezligini ifodalaydi (*skalyar maydon gradiyentining fizik ma‘nosi*). Bunda $u(x, y, z)$ funksiyaning $M(x; y; z)$ nuqtadagi eng katta o‘zgarish tezligi

$$|\operatorname{gradu}| = \sqrt{\left(\frac{\partial u}{\partial x}\right)^2 + \left(\frac{\partial u}{\partial y}\right)^2 + \left(\frac{\partial u}{\partial z}\right)^2} \quad (5.5)$$

bo‘ladi.

⇒ Ikki o‘zgaruvchining $z = z(x, y)$ differensiyallanuvchi funksiyasi bilan berilgan yassi skalyar maydonda gradiyent

$$\operatorname{grad} z = \frac{\partial u}{\partial x} \vec{i} + \frac{\partial z}{\partial y} \vec{j} \quad (5.6)$$

formula bilan aniqlanadi. Bunda $M(x; y)$ nuqtadagi gradiyent sath chizig‘iga shu nuqtada o‘tkazilgan urinmaga perpendikular bo‘ladi.

5-misol. $u = x^2 y^2 z - \ln(z - 1)$ skalyar maydonning $M_0(1;1;2)$ nuqtadagi eng katta hosilasini toping.

☉ Skalyar maydonning eng katta hosilasi bu funksiya gradiyentining moduliga teng bo‘ladi.

Topamiz:

$$\frac{\partial u}{\partial x}\Big|_{M_0} = (2xy^2z)\Big|_{M_0} = 4, \quad \frac{\partial u}{\partial y}\Big|_{M_0} = (2x^2yz)\Big|_{M_0} = 4, \quad \frac{\partial u}{\partial z}\Big|_{M_1} = \left(x^2y^2 - \frac{1}{z-1}\right)\Big|_{M_1} = 0.$$

U holda $\text{gradu} = 4\vec{i} + 4\vec{j}$. Bundan

$$|\text{gradu}| = \sqrt{4^2 + 4^2} = 4\sqrt{2}. \quad \odot$$

6-misol. $z^2 = xy$ sirtning $M_0(4;2)$ nuqtadagi eng katta qiyligini toping.

☞ Sirdagi qiylalikning eng katta absolut qiymati z funksiyaning M nuqtadagi gradiyentining moduliga teng bo'ladi.

Sirt tenglamasidan topamiz:

$$z = \sqrt{xy}, \quad z(M_0) = 2\sqrt{2}, \quad z'_x(M_0) = \frac{1}{2}\sqrt{\frac{y}{x}} = \frac{\sqrt{2}}{4}, \quad z'_y(M_0) = \frac{1}{2}\sqrt{\frac{x}{y}} = \frac{\sqrt{2}}{2}.$$

U holda $\text{gradu} = \frac{\sqrt{2}}{4}\vec{i} + \frac{\sqrt{2}}{2}\vec{j}$. Bundan

$$|\text{gradu}| = \sqrt{\frac{2}{16} + \frac{2}{4}} = \frac{\sqrt{10}}{4}. \quad \odot$$

📌 **2.5.3.** Har bir M nuqtasida biror \vec{a} vektor mos qo'yilgan fazoning biror qismiga (yoki butun fazoga) *vektor maydon* deyiladi. Vektor maydon $Oxyz$ koordinatalar sistemasida $\vec{a} = \vec{a}(x, y, z)$ vektor bilan aniqlanadi. \vec{a} vektor maydonning berilishi uchta skalyar $P = P(x, y, z)$, $Q = Q(x, y, z)$, $R = R(x, y, z)$ maydonning berilishiga teng kuchli bo'ladi, ya'ni

$$\vec{a} = \vec{a}(M) = \vec{a}(x, y, z) = P(x, y, z)\vec{i} + Q(x, y, z)\vec{j} + R(x, y, z)\vec{k}.$$

Agar P, Q, R o'zgarimas kattaliklar bo'lsa vektor maydonga *bir jinsli maydon* deyiladi.

📌 Har bir nuqtasida urinmaning yo'nalishi shu nuqtaga mos \vec{a} vektorning yo'nalishi bilan bir xil bo'lgan chiziq $\vec{a}(M)$ vektor maydonning *vektor chizig'i* deyiladi. Biror yopiq kontur orqali o'tuvchi barcha vektor chiziqlar to'plami *vektor naylari* deyiladi.

$\vec{a}(M)$ vektor maydonning vektor chizig'i

$$\frac{dx}{P(x, y, z)} = \frac{dy}{Q(x, y, z)} = \frac{dz}{R(x, y, z)} \quad (5.7)$$

differensial tenglamalar bilan aniqlanadi.

➡ Agar maydon tekislikda berilgan bo'lsa, ya'ni uning proyeksiyalaridan biri nolga teng bo'lib, qolgan proyeksiyalari tegishli koordinataga bog'liq bo'lmasa *yassi vektor maydon* hosil bo'ladi. Masalan,

$\vec{a}(x, y) = P(x, y)\vec{i} + Q(x, y)\vec{j}$ vektor yassi vektor maydonni ifodalaydi.

Yassi vektor maydon uchun vektor chizig'ining differensial tenglamalari

$$\begin{cases} \frac{dy}{dx} = \frac{Q(x, y)}{P(x, y)}, \\ z = const \end{cases} \quad (5.8)$$

ko'rinishda bo'ladi.

7-misol. Maydonning vektor chiziqlarini toping:

$$1) \vec{a} = x\vec{i} - y\vec{j}; \quad 2) \vec{a} = \frac{1}{x}\vec{i} + \frac{1}{y}\vec{j} + \frac{1}{z}\vec{k}.$$

$$\Leftrightarrow 1) \text{ Vektor maydon yassi. Uning vektor chiziqlari } \frac{dx}{P} = \frac{dy}{Q}$$

tenglamadan topiladi. Bundan $\frac{dx}{x} = -\frac{dy}{y}$. Integrallaymiz:

$$\ln x = -\ln y + \ln C \quad \text{yoki} \quad x = \frac{C}{y}.$$

Demak, vektor chiziqlar $xy = C$ giperbolalar oilasidan iborat.

2) Vektor chiziqlarining tenglamalar sistemasini tuzamiz:

$$\frac{dx}{1} = \frac{dy}{1} = \frac{dz}{z} \quad \text{yoki} \quad xdx = ydy, \quad xdx = zdz.$$

Integrallaymiz:

$$x^2 - y^2 = C_1, \quad x^2 - z^2 = C_2.$$

Demak, vektor chiziqlar ikkita giperbolik silindrlar oilasining kesishish chiziqlaridan iborat. \Leftrightarrow

VCR^3 sohada $\vec{a}(M) = P(x, y, z)\vec{i} + Q(x, y, z)\vec{j} + R(x, y, z)\vec{k}$ vektor maydon berilgan bo'lsin, bunda $P(x, y, z)$, $Q(x, y, z)$, $R(x, y, z) - V$ sohada uzluksiz funksiyalar. V sohada oriyentirlangan σ sirtning har bir nuqtasida normalning musbat yo'nalishi $\vec{n}^0 = \cos\alpha\vec{i} + \cos\beta\vec{j} + \cos\gamma\vec{k}$ birlik vektor bilan aniqlansin, bunda $\alpha, \beta, \gamma - \vec{n}^0$ normal vektorning koordinata o'qlari bilan tashkil qilgan burchaklari.

\square $\vec{a}(M)$ vektor maydonning σ sirt orqali o'tuvchi Π oqimi deb

$$\Pi = \iint_{\sigma} P(x, y, z)dydz + Q(x, y, z)dxdz + R(x, y, z)dxdy \quad (5.9)$$

ikkinchi tur sirt integraliga aytiladi.

Oqimni birinchi va ikkinchi tur sirt integrallari orasidagi bog‘lanishga asosan

$$\Pi = \iint_{\sigma} (P(x, y, z) \cos \beta + Q(x, y, z) \cos \beta + R \cos(x, y, z) \cos \gamma) d\sigma$$

ko‘rinishda yoki vektor shaklda

$$\Pi = \iint_{\sigma} \vec{a} \vec{n}^0 d\sigma \quad (5.10)$$

kabi ifodalash mumkin.

⇒ $\vec{a}(M)$ vektor maydonning oqimi skalyar kattalik hisoblanadi. Agar $\vec{a}(M)$ vektor oqayotgan suyuqlik tezliklari maydonini σ sirt orqali aniqlansa, Π oqim shu sirt orqali vaqt birligi ichida sirtning oriyentirlangan yo‘nalishida oqib o‘tgan suyuqlik miqdoriga teng bo‘ladi (*vektor maydon oqimining fizik ma‘nosi*).

Agar σ sirt fazoning biror sohasini chegaralovchi yopiq sirt bo‘lsa

$$\Pi = \oiint_{\sigma} \vec{a} \vec{n}^0 d\sigma$$

oqim sirtidan oqib chiqayotgan suyuqlik bilan sirtga oqib kirayotgan suyuqlik miqdorlari orasidagi farqni beradi.

8-misol. $\vec{a} = 2x\vec{i} - (z-1)\vec{k}$ vektor maydonning $\sigma: x^2 + y^2 = 4, z=0, z=1$ sirtidan tashqi tomonga o‘tuvchi oqimini toping.

⊕ \vec{a} vektor maydon oqimi

$\Pi = \Pi_1 + \Pi_2 + \Pi_3$ ga teng (17-shakl). Bunda

$$\Pi_1 = \iint_{\sigma_1} \vec{a} \vec{n}_1^0 d\sigma = \iint_{\sigma_1} (z-1) d\sigma = \iint_{\sigma_1} (0-1) d\sigma = -\iint_{\sigma_1} d\sigma = -4\pi,$$

$$\Pi_2 = \iint_{\sigma_2} \vec{a} \vec{n}_2^0 d\sigma = -\iint_{\sigma_2} (z-1) d\sigma = -\iint_{\sigma_2} (1-1) d\sigma = 0,$$

$$\Pi_3 = \iint_{\sigma_3} \vec{a} \vec{n}_3^0 d\sigma = \iint_{\sigma_3} x^2 d\sigma, \text{ chunki } \vec{n}_3^0 = \frac{x\vec{i} + y\vec{j}}{2},$$

$$\begin{aligned} \Pi_3 &= \iint_{\sigma_3} x^2 d\sigma = \int_0^{2\pi} 4 \cos^2 \varphi d\varphi \int_0^2 r dr = \\ &= 4 \int_0^{2\pi} \frac{1 + \cos 2\varphi}{2} d\varphi = 4\varphi \Big|_0^{2\pi} = 8\pi. \end{aligned}$$

Demak,

$$\Pi = -4\pi + 0 + 8\pi = 4\pi. \quad \ominus$$

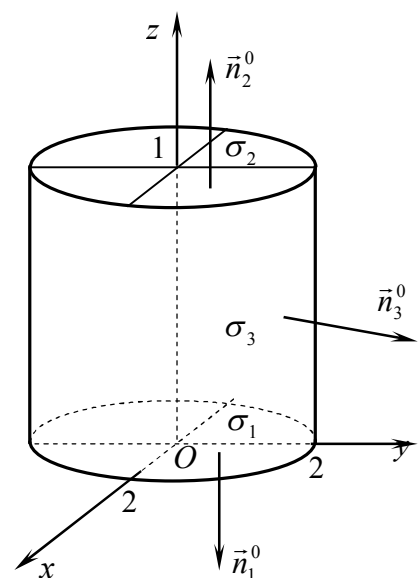

17-shakl.

2.5.4. VCR^3 sohada $\vec{a}(M) = P(x, y, z)\vec{i} + Q(x, y, z)\vec{j} + R(x, y, z)\vec{k}$ vektor maydon berilgan bo‘lsin, bunda $P(x, y, z), Q(x, y, z), R(x, y, z) - V$ sohada differensiallanuvchi funksiyalar.

☐ $\vec{a}(M)$ vektor maydon divergensiya deb

$$\operatorname{div} \vec{a}(M) = \frac{\partial P}{\partial x} + \frac{\partial Q}{\partial y} + \frac{\partial R}{\partial z} \quad (5.11)$$

tenglik bilan aniqlanadigan skalyar maydonga aytiladi.

Divergeniya va oqim ta'riflaridan Ostrogradskiy-Gauss formulasi

$$\Pi = \oiint_{\sigma} \vec{a} \vec{n}^0 d\sigma = \iiint_V \operatorname{div} \vec{a}(M) dV \quad (5.12)$$

vektor shakli kelib chiqadi.

9-misol. $\vec{a} = xz^2 \vec{i} + yx^2 \vec{j} + zy^2 \vec{k}$ vektor maydonning $x^2 + y^2 + z^2 = R^2$ sferadan tashqi tomonga o'tuvchi oqimini toping.

☞ Oqimni Ostrogradskiy-Gauss formulasi bilan topamiz:

$$\begin{aligned} \Pi &= \iiint_V \operatorname{div} \vec{a} dV = \iiint_V (z^2 + x^2 + y^2) dx dy dz = (\text{sferik koordinatalarga o'tamiz}) = \\ &= \iiint_V r^4 \sin \theta dr d\theta d\varphi = \int_0^R r^4 dr \int_0^\pi \sin \theta d\theta \int_0^{2\pi} d\varphi = \int_0^R r^4 dr \int_0^\pi \sin \theta \cdot \varphi \Big|_0^{2\pi} d\theta = \\ &= -2\pi \int_0^R r^4 \cos \theta \Big|_0^\pi dr = 4\pi \int_0^R r^4 dr = 4\pi \frac{r^5}{5} \Big|_0^R = \frac{4R^5 \pi}{5}. \quad \bullet \end{aligned}$$

☞ Agar $\vec{a}(M)$ vektor σ sirt orqali oqayotgan suyuqlik tezliklari maydonini ifodalasa, $\operatorname{div} \vec{a}(M)$ berilgan nuqtadagi suyuqlik sarfining hajm birligiga nisbatini beradi (*divergensiyaning fizik ma'nosi*).

☐ Har bir nuqtasida divergeniya nolga teng, ya'ni $\operatorname{div} \vec{a}(M) = 0$ bo'lgan maydonga *solenoidli* (yoki *nayli*) maydon deyiladi. Solenoidli maydonda vektor nayining har bir kesimidan bir xil miqdorda suyuqlik oqib o'tadi.

2.5.5. VCR^3 sohada yo'nalishi tanlangan biror L chiziq va $\vec{a}(M) = P(x, y, z)\vec{i} + Q(x, y, z)\vec{j} + R(x, y, z)\vec{k}$ vektor maydon berilgan bo'lsin, bunda $P(x, y, z)$, $Q(x, y, z)$, $R(x, y, z) - V$ sohada differensiallanuvchi funksiyalar.

☐ Yo'nalgan L chiziq bo'yicha olingan

$$\int_L P(x, y, z) dx + Q(x, y, z) dy + R(x, y, z) dz = \int_L \vec{a} d\vec{r} \quad (5.13)$$

ikkinchi tur egri chizikli integralga $\vec{a}(M)$ vektorning L chiziq bo'yicha olingan *chizikli integrali* deyiladi.

☞ Agar $\vec{a}(M)$ vektor kuch maydonini hosil qilsa, $\vec{a}(M)$ vektorning L chiziq bo'yicha olingan chizikli integrali tayin yo'nalishda L chiziq bo'yicha bajarilgan ishga teng bo'ladi (*chizikli integralning fizik ma'nosi*).

☐ $\vec{a}(M)$ vektor maydonning L yopiq kontur bo'yicha *sirkulatsiyasi* deb

$$\mathcal{L} = \oint_L \vec{a} d\vec{r} = \oint_L P(x, y, z) dx + Q(x, y, z) dy + R(x, y, z) dz \quad (5.14)$$

chiziqli integralga aytiladi.

2.5.6. VCR^3 sohada $\vec{a}(M) = P(x, y, z)\vec{i} + Q(x, y, z)\vec{j} + R(x, y, z)\vec{k}$ vektor maydon berilgan bo'lsin, bunda $P(x, y, z), Q(x, y, z), R(x, y, z) - V$ sohada differensiallanuvchi funksiyalar.

☐ $\vec{a}(M)$ vektor maydonning *uyurmasi* (yoki *rotori*) deb

$$\text{rot}\vec{a}(M) = \left(\frac{\partial R}{\partial y} - \frac{\partial Q}{\partial z} \right) \vec{i} + \left(\frac{\partial P}{\partial z} - \frac{\partial R}{\partial x} \right) \vec{j} + \left(\frac{\partial Q}{\partial x} - \frac{\partial P}{\partial y} \right) \vec{k} \quad (5.15)$$

vektorga aytiladi.

Uyurma va sirkulatsiya ta'riflaridan foydalanib Stoks formulasini vektor shaklda quyidagicha yozish mumkin:

$$\mathcal{L} = \oint_L \vec{a} d\vec{r} = \iint_{\sigma} \vec{n} \text{rot}\vec{a} d\sigma. \quad (5.16)$$

10-misol. $a = y\vec{i} - x\vec{j} + a\vec{k}$ ($a = \text{const}$) vektor maydonning $x^2 + y^2 = 1, z = 0$ aylananing musbat yo'nalishi bo'yicha sirkulatsiyasini ta'rifdan foydalanib (1) va Stoks formulasi bilan (2) toping.

☞ 1) L chiziqni parametrik ko'rinishda yozamiz:

$$x = \cos t, \quad y = \sin t, \quad z = 0, \quad 0 \leq t \leq 2\pi.$$

Bundan $dx = -\sin t dt, dy = \cos t dt, dz = 0$. U holda

$$\mathcal{L} = \oint_L y dx - x dy + a dz = \int_0^{2\pi} (\sin t (-\sin t) - \cos t \cos t) dt = -\int_0^{2\pi} d\varphi = -2\pi.$$

2) Masala shartidan: $P = y, Q = -x, R = a$. (5.16) formuladan topamiz:

$$\text{rot}\vec{a} = \left(\frac{\partial a}{\partial y} - \frac{\partial x}{\partial z} \right) \vec{i} + \left(\frac{\partial y}{\partial z} - \frac{\partial a}{\partial x} \right) \vec{j} + \left(-\frac{\partial x}{\partial x} - \frac{\partial y}{\partial y} \right) \vec{k} = -2\vec{k}.$$

Aylananing musbat yo'nalishi $\vec{n} = \vec{k}$ normal bilan aniqlanadi.

Stoks formulasi (5.17) bilan topamiz:

$$\begin{aligned} \mathcal{L} &= \iint_{\sigma} \vec{n} \text{rot}\vec{a} d\sigma = -2 \iint_{\delta_{xy}} \vec{n} \vec{k} d\sigma = -2 \iint_{\delta_{xy}} dx dy = -2 \int_0^{2\pi} d\varphi \int_0^1 r dr = \\ &= -2 \int_0^{2\pi} \frac{r^2}{2} \Big|_0^1 d\varphi = -\int_0^{2\pi} d\varphi = -\varphi \Big|_0^{2\pi} = -2\pi. \quad \ominus \end{aligned}$$

☞ Tezlik maydonning uyurmasi jism aylanishining oniy burchak tezligi vektoriga kollinear vektor bo'ladi (*uyurmaning fizik ma'nosi*).

☑ Har bir nuqtasida uyurmasi nolga teng, ya'ni $\text{rot}\vec{a}(M) = 0$ bo'lgan maydon *potensial maydon* deyiladi.

☑ Gradiyenti $\vec{a}(x, y, z)$ vektor maydonni yuzaga keltiruvchi $u(x, y, z)$ skalyar funksiyaga shu vektor maydonning *potensial funksiyasi* (yoki *potensial*) deyiladi.

Agar $V \subset R^3$ soha bir bog'lamli bo'lsa, potensial maydondagi chiziqli integral integrallash yo'liga bog'liq bo'lmaydi. Bu holda potensial quyidagi formula bilan topiladi:

$$\begin{aligned} u(x, y, z) &= \int_{AB} P(x, y, z)dy + Q(x, y, z)dy + R(x, y, z)dz = \\ &= \int_{x_0}^x P(x, y_0, z_0)dx + \int_{y_0}^y Q(x, y, z_0)dy + \int_{z_0}^z R(x, y, z)dz. \end{aligned}$$

Masqlar

2.5.1. Funksiyalarning M_0 nuqtada berilgan yo'nalish bo'yicha hosilasini toping:

- 1) $z = x^2 + xy^2$, $\overline{M_0M_1}$ vektor yo'nalishida, bu yerda $M_0(1;2)$, $M_1(3;0)$;
- 2) $z = \ln(3x^2 + 2y^3)$, $\vec{a} = \{3;1\}$ vektor yo'nalishida, bu yerda $M_0(-1;2)$;
- 3) $z = 2xy + y^2$, $\frac{x^2}{4} + \frac{y^2}{2} = 1$ ellips yo'nalishida, bu yerda $M_0(\sqrt{2};1)$;
- 4) $u = xy + yz + xz$, $\overline{M_0M_1}$ vektor yo'nalishida, bu yerda $M_0(1;2;3)$, $M_1(5;5;15)$;
- 5) $u = x^2 + y^2 + z^2$, $\vec{a} = \{\cos 60^\circ; \cos 60^\circ; \cos 45^\circ\}$ vektor yo'nalishida, bu yerda $M_0(1;1;1)$;
- 6) $u = x^{yz}$, $\vec{a} = \{2;2;-1\}$ vektor yo'nalishida, bu yerda $M_0\left(e;2;\frac{1}{2}\right)$;
- 7) $u = z \ln(x^2 + y^2 - z)$, $x = 2 \cos t$, $y = 2 \sin t$, $z = 3$, $0 \leq t \leq 2\pi$ aylana yo'nalishida, bu yerda $M_0(1;-\sqrt{3};3)$.

2.5.2. Funksiyalarning berilgan nuqtadagi eng katta o'zgarish tezligini toping:

- 1) $u = x^2yz - xy^2z + xyz^2$, $M_0(-2;1;0)$;
- 2) $u = \ln(1 + x + y^2 + z^2)$, $M_0(1;1;1)$;
- 3) $u = e^{xy+z^2}$, $M_0(-1;4;-2)$;
- 4) $u = x^2 \operatorname{arctg}(3y - z)$, $M_0(2;1;3)$.

2.5.3. Berilgan nuqtada u va v skalyar maydonlar sath sirtlari orasidagi burchakni toping:

1) $u = x^2 + y^2 - z^2$, $v = xz + yz$, $M_0(-2;1;2)$;

2) $u = 2x^2y + z^2 - x$, $v = x^2z - y^2$, $M_0(1;0;2)$.

2.5.4. Vektor maydonlarning vektor chiziqlarini toping:

1) $\vec{a} = x\vec{i} + y\vec{j} + z\vec{k}$; 2) $\vec{a} = 2xy\vec{i} + 2y\vec{j} + 3z\vec{k}$; 3) $\vec{a} = 2z\vec{i} - 3x\vec{k}$.

2.5.5. Vektor maydon oqimini uning ta'rifi orqali toping:

1) $\vec{a} = x\vec{i} + y\vec{j} + z\vec{k}$ ning $x^2 + y^2 + z^2 = R^2$ sferadan tashqi tomonga o'tuvchi;

2) $\vec{a} = xz\vec{i}$ ning $x^2 + y^2 + z = 1$ paraboloiddan tashqi tomonga o'tuvchi.

2.5.6. Vektor maydon oqimini Ostrogradskiy-Gauss formulasi bilan toping:

1) $\vec{a} = 4x^3\vec{i} + 4y^3\vec{j} - 6z^4\vec{k}$ ning $x^2 + y^2 = 9$ silindrning $z = 0$ va $z = 2$ tekisliklar orasidagi sirtidan tashqi tomonga o'tuvchi;

2) $\vec{a} = xz^2\vec{i} + yx^2\vec{j} + zy^2\vec{k}$ ning $x^2 + y^2 + z^2 = R^2$ sferadan tashqi tomonga o'tuvchi;

3) $\vec{a} = x\vec{i} + y\vec{j} + z\vec{k}$ ning $x^2 + y^2 = R^2$ ($-H \leq z \leq H$) silindrik sirtidan tashqi tomonga o'tuvchi;

4) $\vec{a} = x\vec{i} + y\vec{j} + z\vec{k}$ ning $z = 1 - \sqrt{x^2 + y^2}$, $z = 0$ ($0 \leq z \leq 1$) yopiq sirtidan tashqi tomonga o'tuvchi;

5) $\vec{a} = z\vec{k}$ ning $z = x$ tekislikning $x = 0$, $y = 0$, $x + y = 1$ piramida ichidagi qismidan tashqi tomonga o'tuvchi;

6) $\vec{a} = 8x\vec{i} + (2x - 4y)\vec{j} + (e^x - z)\vec{k}$ ning $x^2 + y^2 + z^2 = 2y$ sferadan tashqi tomonga o'tuvchi.

2.57. Vektor maydon divergensiyasini berilgan nuqtada toping:

1) $\text{grad} \sqrt{x^2 + y^2 + z^2}$, $M_0(2;-1;2)$;

2) $\vec{a} \times \vec{b}$, $\vec{a} = x\vec{i} + y\vec{j} + z\vec{k}$, $\vec{b} = y\vec{i} + z\vec{j} + x\vec{k}$, $M_0(3;1;-2)$.

2.5.8. Vektor maydon sirkulatsiyasini ta'rifi orqali toping va natijani Stoks formulasi bilan tekshiring:

1) $\vec{a} = (x + z)\vec{i} + (x - y)\vec{j} + x\vec{k}$, $\frac{x^2}{a^2} + \frac{y^2}{b^2} = 1$ ellips bo'yicha;

2) $\vec{a} = -y\vec{i} + x\vec{j} + 5\vec{k}$, $x^2 + y^2 = 1$, $z = 0$ aylana bo'yicha;

3) $\vec{a} = x^2 y^3 \vec{i} + 2\vec{j} + z^2 \vec{k}$, $x^2 + y^2 + z^2 = 4$ sferaning $z=0$ tekislik bilan kesishish chizig‘i bo‘yicha;

4) $\vec{a} = z\vec{i} + 2yz\vec{j} + y^2\vec{k}$, $x^2 + 9y^2 = 9 - z$ sirtning koordinata tekisliklari bilan kesishish chizig‘i bo‘yicha.

2.5.9. Vektor maydon uyurmasining berilgan nuqtadagi kattaligini toping:

1) $\vec{a} = z^2 \vec{i} + x^2 \vec{j} + y^2 \vec{k}$, $M_0(-1;2;2)$;

2) $\vec{a} = xyz\vec{i} + (x + y + z)\vec{j} + (x^2 + y^2 + z^2)\vec{k}$, $M_0(1;2;-3)$.

NAZORAT ISHI

1. Berilgan chiziqlar bilan chegaralangan D soha uchun $\iint_D f(x,y) dx dy$ ikki karrali integralning takroriy integrallarini yozing.

2. $u = u(x,y,z)$ funksiyaning $M(x_0; y_0; z_0)$ nuqtadagi eng katta o‘zgarish kattaligi va yo‘nalishini toping.

1-variant

1. $y = -x$, $y^2 = 2x + 3$.

2. $u = 2x^2 yz$, $M(-3;0;2)$.

2-variant

1. $y = 2x - x^2$, $y = -x$.

2. $u = 3x^2 + y^2 - z^2$, $M(0;0;1)$.

3-variant

1. $y = x$, $y^2 = 2 - x$.

2. $u = 3x^2 yz^3$, $M(-2;-3;1)$.

4-variant

1. $y^2 = 16 - 9x$, $y^2 - 23x = 48$.

2. $u = z(x + y)$, $M(1;-1;0)$.

5-variant

1. $y^2 - 3x = 4$, $y^2 + 4x = 11$.

2. $u = xyz$, $M(-2;1;0)$.

6-variant

1. $x = -1$, $x = -2$, $y \geq 0$, $y = x^2$.

2. $u = (x + z)y^2$, $M(0;4;-1)$.

7-variant

1. $y = 3 - x^2, y = -2x.$

2. $u = x^2 y^3 z, M(-2;1;0).$

8-variant

1. $y = -x, y = 3, 3x + y = 3.$

2. $u = y^2(x^2 + z), M(1;4;-3).$

9-variant

1. $y = 1, y = 0, x = 2y, x - 8 = 2y.$

2. $u = x^2 y z^2, M(-1;3;0).$

10-variant

1. $y = x^2, x - y + 2 = 0.$

2. $u = y^2(x + z^2), M(0;3;1).$

11-variant

1. $y = 0, y = 3, x = y, x - 6 = y.$

2. $u = xy^2 z^2, M(-2;1;1).$

12-variant

1. $y = x^2 - 4x, y = x.$

2. $u = x^2 y - z, M(2;-1;1).$

13-variant

1. $y = \sqrt{4 - x^2}, x = 1, x \geq 0, y = 0.$

2. $u = x + yz^2, M(2;2;1).$

14-variant

1. $x^2 = 2y, 5x - 2y = 6.$

2. $u = (y^2 - x)z^2, M(3;1;0).$

15-variant

1. $y = x^2 - 2, y = x.$

2. $u = (y^2 + z)x, M(1;-4;0).$

16-variant

1. $y^2 = 2x, x^2 = 2y, x \leq 1.$

2. $u = (x + z)y^2, M(2;2;2).$

17-variant

1. $x = \sqrt{8 - y^2}, y \geq 0, y = x.$

2. $u = x^2 y^2 z^2, M(2;1;-1).$

18-variant

1. $x^2 = 2 - y, x + y = 0.$

2. $u = x(y + z), M(2;0;-2).$

19-variant

1. $xy = 9, x + y = 10, 1 \leq y \leq 3.$

2. $u = x^2 y + y^2 z, M(0;-2;1).$

20-variant

1. $y = \sqrt{5 - x^2}$, $x = y + 1$.

2. $u = xy - yz$, $M(2; -1; 1)$.

21-variant

1. $y = x$, $y = x + 3$, $y = 2x$, $y = 2x - 3$.

2. $u = x^2z - y^2$, $M(1; 1; -2)$.

22-variant

1. $y = 9 - x^2$, $y \geq 2x^2$.

2. $u = y(x^2 + z^2)$, $M(-2; 1; 1)$.

23-variant

1. $y = \sqrt{2 - x^2}$, $y = x^2$.

2. $u = y^2z - x^2$, $M(0; 1; 1)$.

24-variant

1. $x + 2y = 6$, $y = x$, $y \geq 0$.

2. $u = x^2 + y^2 + z^2$, $M(1; -1; 2)$.

25-variant

1. $y \geq x^2 + 2x$, $y = x + 2$.

2. $u = x^2y + xz^2 - 2$, $M(1; 1; -1)$.

26-variant

1. $x = \sqrt{5 - y^2}$, $y - x - 1 = 0$.

2. $u = xy^2 + yz^2 + zx^2$, $M(1; 2; 3)$.

27-variant

1. $y = 3x$, $y + 4 = x^2$, $x \geq 0$.

2. $u = x^3yz^2 + x + y + z$, $M(2; 0; -1)$.

28-variant

1. $y = 3 - x$, $y = 1 + x$, $x = 0$, $x = 1$.

2. $u = xyz + x^2y^2z^2$, $M(-3; -2; 0)$.

29-variant

1. $y = x^2 - 4x$, $2x - y = 5$.

2. $u = xyz^2 + xzy^2$, $M(0; 1; -1)$.

30-variant

1. $2y = x$, $y^2 = x + 3$, $y \geq 0$.

2. $u = x^3 + 2y^2 + 3z$, $M(2; -1; 1)$.

MUSTAQIL UY ISHI

1. Ikki karrali integralni hisoblang.
2. Berilgan chiziqlar bilan chegaralangan D tekis shakl yuzasini toping.
3. Uch karrali integrallarni hisoblang.
4. Berilgan sirtlar bilan chegaralangan jismning hajmini uch karrali integral bilan toping.
5. Birinchi tur egri chiziqli integralni hisoblang.
6. Ikkinchi tur egri chiziqli integrallarni hisoblang.
7. Birinchi tur sirt integralini hisoblang, bu yerda σ – D tekislikning koordinata tekisliklari bilan ajratilgan qismi.
8. $u = u(x, y, z)$ funksiyaning M_1 nuqtadagi $\overrightarrow{M_1M_2}$ vektor yo‘nalishidagi hosilasini toping.
9. \vec{a} vektor maydon oqimini D tekislik va koordinata tekisliklaridan hosil bo‘lgan piramidaning tashqi sirti bo‘yicha ikki usul bilan hisoblang: 1) oqim ta’rifidan foydalanib; 2) Ostrogradskiy-Gauss formulasi orqali.
10. \vec{a} vektor maydon sirkulatsiyasini $Ax + By + Cz = D$ tekislikning koordinata tekisliklari bilan kesishishidan hosil bo‘lgan uchburchakning $\vec{n} = \{A; B; C\}$ vektorga nisbatan musbat yo‘nalishda aylanib konturi bo‘yicha ikki usul bilan hisoblang: 1) sirkulatsiya ta’rifidan foydalanib; 2) Stoks formulasi orqali.

1-variant

1. $\iint_D y(1+x^2) dx dy$, $D: y = x^3, y = 3x$.
2. $x = 27 - y^2, x = -6y$.
3. $\iiint_V xy^2 z dx dy dz$, $V: -2 \leq x \leq 1, 0 \leq y \leq 2, 0 \leq z \leq 3$.
4. $x \geq 0, y \geq 0, z \geq 0, 2x + y = 2, z = y^2$.
5. $\int_L y dl$, $L: y^2 = 2x$ parabolaning $x^2 = 2y$ parabola kesgan yoyi.
6. $\int_L (xy - 1) dx + x^2 y dy$, $L: A(1;0)$ va $B(0;2)$ nuqtalarni tutashtiruvchi AB to‘g‘ri chiziq kesmasi.
7. $\iint_{\sigma} z d\sigma$, $D: x + y + z = 1$.
8. $u = \ln(1 + x^2 + y^2 + z^2)$, $M_1(1;1;1)$, $M_2(5;-4;8)$.
9. $\vec{a} = (3x + y)\vec{i} + (x + z)\vec{j} + y\vec{k}$, $D: 2x + y + 3z = 6$.
10. $\vec{a} = (3x - y)\vec{i} + (2y + z)\vec{j} + (2z - x)\vec{k}$, $2x - 3y + z = 6$.

2-variant

1. $\iint_D (xy - 4x^3y^3) dx dy$, $D: x=1, y=x^2, y=-\sqrt{x}$.
2. $y=x^2, y=\frac{3}{4}x^2+1$.
3. $\iiint_V (x^2+y^2+z^2) dx dy dz$, $V: x^2+y^2+z^2=4, x \geq 0, y \geq 0, z \geq 0$.
4. $x^2+y^2=2y, z=\frac{13}{4}-x^2, z=0$.
5. $\int_L x^2 dl$, $L: x^2+y^2=R^2$ aylananing yuqori yoyi.
6. $\int_L (xy-y)^2 dx + x dy$, $L: y=x^2$ parabolaning $O(0;0)$ nuqtadan $B(1;1)$ nuqtagacha bo'lgan yoyi.
7. $\iint_{\sigma} (x+3y+2z) d\sigma$, $D: 2x+y+2z=2$.
8. $u=x^2+2y^2-4z^2-5$, $M_1(1;2;1), M_2(-3;-2;6)$.
9. $\vec{a}=(x+y)\vec{i}+(y+z)\vec{j}+2(z+x)\vec{k}$, $D: 3x-2y+2z=6$.
10. $\vec{a}=(x+2z)\vec{i}+(y-3z)\vec{j}+z\vec{k}$, $3x+2y+2z=6$.

3-variant

1. $\iint_D \sqrt{1-x^2-y^2} dx dy$, $D: x^2+y^2=4$.
2. $y^2-2y+x^2=0, y^2-4y+x^2=0, y=x, x=0$.
3. $\iiint_V 21xz dx dy dz$, $V: y=x, y=0, x=2, z=xy, z=0$.
4. $z=3-7(x^2+y^2), z=3-14x$.
5. $\oint_L (x^2+y^2) dl$, $L: x^2+y^2=4x$ aylana.
6. $\oint_L (x^2y-x) dx + (y^2x-2y) dy$, $L: x=3\cos t, y=2\sin t$ ellipsning musbat yo'nalishda aylanib o'tishdagi yoyi.
7. $\iint_{\sigma} (6x+4y+3z) d\sigma$, $D: x+2y+3z=6$.
8. $u=\ln(xy+yz+xz)$, $M_1(-2;3;-1), M_2(2;1;-3)$.
9. $\vec{a}=(x+y)\vec{i}+3y\vec{j}+(y-z)\vec{k}$, $D: 2x-y-2z=-2$.
10. $\vec{a}=(x+z)\vec{i}+(x+3y)\vec{j}+y\vec{k}$, $2x+2y+z=2$.

4-variant

1. $\iint_D y \sin xy dx dy$, $D: y = \frac{\pi}{2}, y = \pi, x = 1, x = 2$.
2. $x = 4 - y^2, x - y + 2 = 0$.
3. $\iiint_V (xy - z^2) dx dy dz$, $V: 0 \leq x \leq 1, -1 \leq y \leq 2, 0 \leq z \leq 3$.
4. $z = 8(x^2 + y^2) + 3, z = 16x + 3$.
5. $\oint_L (x + y) dl$, L : uchlari $A(1;0), B(0;1), O(0;0)$ nuqtalarda bo'lgan uchburchak konturi.
6. $\int_L x dy$, L : $y = \sin x$ sinusoidaning $O(\pi;0)$ nuqtadan $B(0;0)$ nuqtagacha bo'lgan yoyi.
7. $\iint_{\sigma} (4y - x + 4z) d\sigma$, $D: x - 2y + 2z = 2$.
8. $u = x^2 y + y^2 z + z^2 x$, $M_1(1;-1;2), M_2(3;4;-1)$.
9. $\vec{a} = 3x\vec{i} + (y + z)\vec{j} + (x - z)\vec{k}$, $D: x + 3y + z = 3$.
10. $\vec{a} = z\vec{i} + (x + y)\vec{j} + y\vec{k}$, $2x + y + 2z = 2$.

5-variant

1. $\iint_D (6xy + 24x^3 y^3) dx dy$, $D: x = 1, y = \sqrt{x}, y = -x^2$.
2. $x = y^2, y^2 = 4 - x$.
3. $\iiint_V 5xyz^2 dx dy dz$, $V: -1 \leq x \leq 0, 2 \leq y \leq 3, 1 \leq z \leq 2$.
4. $x \geq 0, z \geq 0, x + y = 4, z = 4\sqrt{y}$.
5. $\int_L y x dl$, L : $y^2 = 6x$ parabolaning $x^2 = 6y$ parabola kesgan yoyi.
6. $\oint_L y dx - x dy$, L : $r = R$ aylananing musbat yo'nalishda aylanib o'tishdagi yoyi.
7. $\iint_{\sigma} (5x - 8y - z) d\sigma$, $D: 2x - 3y + z = 6$.
8. $u = \frac{10}{1 + x^2 + y^2 + z^2}$, $M_1(-1;2;-2), M_2(2;0;1)$.
9. $\vec{a} = (y + z)\vec{i} + (2x - z)\vec{j} + (y + 3z)\vec{k}$, $D: 2x + y + 3z = 6$.
10. $\vec{a} = (x + z)\vec{i} + 2y\vec{j} + (x + y - z)\vec{k}$, $x + 2y + z = 2$.

6-variant

1. $\iint_D x(y-1)dx dy$, $D: y=5x, y=x, x=3$.
2. $x=8-y^2, x=-2y$.
3. $\iiint_V (3x^2+y^2)dx dy dz$, $V: z=10y, x+y=1, x=0, y=0, z=0$.
4. $x^2+y^2=4x, z=10-y^2, z=0$.
5. $\int_L y^2 dl$, $L: x=3(t-\sin t), y=3(1-\cos t)$ sikloidaning bir arkasi.
6. $\int_L \cos z dx - \sin x dz$, $L: A(2;0;-2)$ va $B(-2;0;2)$ nuqtalarni tutashtiruvchi AB to'g'ri chiziq kesmasi.
7. $\iint_\sigma (2x+3y+2z)d\sigma$, $D: x+3y+z=3$.
8. $u=x-2y+e^x$, $M_1(-4;-5;0)$, $M_2(2;3;4)$.
9. $\vec{a}=(x+y+z)\vec{i}+2z\vec{j}+(y-7z)\vec{k}$, $D: 2x+3y+z=6$.
10. $\vec{a}=x\vec{i}+(y-2z)\vec{j}+(2x-y+2z)\vec{k}$, $x+2y+2z=2$.

7-variant

1. $\iint_D \frac{dx dy}{1+x^2+y^2}$, $D: x^2+y^2=9$.
2. $y=\frac{3}{x}, y=8e^x, y=3, y=8$.
3. $\iiint_V (x-y-z)dx dy dz$, $V: 0 \leq x \leq 3, 0 \leq y \leq 1, -2 \leq z \leq 1$.
4. $z=-2(x^2+y^2)-1, z=4y-1$.
5. $\oint_L xy dl$, $L: \text{tomonlari } x=1, x=-1, y=1, y=-1 \text{ bo'lgan kvadrat konturi}$.
6. $\int_L \frac{y dx + x dy}{x^2+y^2}$, $L: A(1;2)$ va $B(3;6)$ nuqtalarni tutashtiruvchi AB to'g'ri chiziq kesmasi.
7. $\iint_\sigma (5x-y+5z)d\sigma$, $D: 3x+2y+z=6$.
8. $u=\sqrt{1+x^2+y^2+z^2}$, $M_1(1;1;1)$, $M_2(3;2;1)$.
9. $\vec{a}=(x+y-z)\vec{i}-2y\vec{j}+(x+2z)\vec{k}$, $D: x+2y+z=2$.
10. $\vec{a}=(2y-z)\vec{i}+(x+y)\vec{j}+x\vec{k}$, $x+2y+2z=4$.

8-variant

1. $\iint_D y \cos xy dx dy$, $D: y = \frac{\pi}{2}, y = \pi, x = 1, x = 2$.
2. $x^2 - 2x + y^2 = 0, x^2 - 6x + y^2 = 0, y = 0, y = \frac{x}{\sqrt{3}}$.
3. $\iiint_V (y^2 + z) dx dy dz$, $V: z = x + y, x + y = 1, x = 0, y = 0, z = 0$.
4. $x^2 + y^2 = 9, z = 5 - x - y, z \geq 0$.
5. $\oint_L \sqrt{x^2 + y^2} dl$, $L: x^2 + y^2 = 2y$ aylana.
6. $\int_L (x^2 + y) dx + (x + y^2) dy$, $L: ABC$ sinliq chiziq, $A(2;0), B(5;3), C(5;0)$.
7. $\iint_\sigma (7x + y + 2z) d\sigma$, $D: 3x - 2y + 2z = 6$.
8. $u = 5xy^3z^2$, $M_1(2;1;-1), M_2(4;-3;0)$.
9. $\vec{a} = (3x - 1)\vec{i} + (y - x + z)\vec{j} + 4z\vec{k}$, $D: 2x - y - 2z = 2$.
10. $\vec{a} = (x + z)\vec{i} + z\vec{j} + (2x - y)\vec{k}$, $3x + 2y + z = 2$.

9-variant

1. $\iint_D ye^{\frac{xy}{2}} dx dy$, $D: y = \ln 2, y = \ln 3, x = 2, x = 4$.
2. $x = 5 - y^2, x = -4y$.
3. $\iiint_V y^2 dx dy dz$, $V: z = 2(3x + y), x + y = 1, x = 0, y = 0, z = 0$.
4. $z \geq 0, x^2 + y^2 = 4, z = x^2 + y^2$.
5. $\int_L (x + y) dl$, $L: r^2 = \cos 2\varphi \left(-\frac{\pi}{4} \leq \varphi \leq \frac{\pi}{4} \right)$ Bernulli limniskatasining bo'lagi.
6. $\int_L 4x \sin^2 y dx + y \cos 2x dy$, $L: A(0;0)$ va $B(3;6)$ nuqtalarni tutashtiruvchi AB to'g'ri chiziq kesmasi.
7. $\iint_\sigma (3y - x - z) d\sigma$, $D: x - y + z = 2$.
8. $u = \frac{x}{y} + \frac{y}{z} - \frac{z}{x}$, $M_1(-1;1;1), M_2(2;3;4)$.
9. $\vec{a} = (y + z)\vec{i} + (x + 6y)\vec{j} + y\vec{k}$, $D: x + 2y + 2z = 2$.
10. $\vec{a} = (y + 2z)\vec{i} + (x + 2z)\vec{j} + (x - 2y)\vec{k}$, $2x + y + 2z = 2$.

10-variant

1. $\iint_D y^2(1+2x)dxdy$, $D: y=2-x^2, x=0$.
2. $x=y^2, x=\frac{3}{4}y^2+1$.
3. $\iiint_V (2x-y^2-z)dxdydz$, $V: 1\leq x\leq 5, 0\leq y\leq 2, -1\leq z\leq 0$.
4. $z\geq 0, y^2=2-x, z=3x$.
5. $\int_L (4\sqrt[3]{x}-3\sqrt{y})dl$, $L: A(-1;0)$ va $B(0;1)$ nuqtalarni tutashtiruvchi to'g'ri

chiziq kesmasi.

6. $\int_L \frac{x^2 dy - y^2 dx}{3\sqrt[3]{x^5} + \sqrt[3]{y^5}}$, $L: x=2\cos^3 t, y=2\sin^3 t$ astroidaning $A(2;0)$ nuqtadan

$B(0;2)$ nuqttagacha bo'lgan yoyi.

7. $\iint_{\sigma} (2+y-7x+9z)d\sigma$, $D: 2x-y-2z=-2$.
8. $u=\ln(1+x^3+y^3+z)$, $M_1(1;3;0)$, $M_2(-4;1;3)$.
9. $\vec{a}=(2x-z)\vec{i}+(y-x)\vec{j}+(x+2z)\vec{k}$, $D: x-y+z=2$.
10. $\vec{a}=(y-z)\vec{i}+(2x+y)\vec{j}+z\vec{k}$, $2x+y+z=2$.

11-variant

1. $\iint_D xy^2 dxdy$, $D: y=x, y=0, x=1$.
2. $y=\frac{\sqrt{x}}{2}, y=\frac{1}{2x}, x=\frac{y}{2}$.
3. $\iiint_V x^2 yz dxdydz$, $V: -1\leq x\leq 2, 0\leq y\leq 3, 2\leq z\leq 3$.
4. $x\geq 0, z\geq 0, x+y=2, z=y^2$.
5. $\int_L (x^2+y^2)dl$, $L: r=2$ aylananing birinchi choragi.
6. $\int_L xydx+(y-x)dy$, $L: y=x^3$ kubik parabolaning $O(0;0)$ nuqtadan

$B(1;1)$ nuqttagacha bo'lgan yoyi.

7. $\iint_{\sigma} (2x+3y+z)d\sigma$, $D: 2x+2y+z=2$.
8. $u=\ln(2+y^2+z^2)$, $M_1(-1;2;1)$, $M_2(3;1;-1)$.
9. $\vec{a}=(y-z)\vec{i}+(2x+y)\vec{j}+z\vec{k}$, $D: 2x+y+z=2$.
10. $\vec{a}=(2z-x)\vec{i}+(x-y)\vec{j}+(3x+z)\vec{k}$, $x+y+2z=2$.

12-variant

1. $\iint_D e^y dx dy$, $D: y = \ln x, y = 0, x = e$.
2. $y = \sqrt{2 - x^2}, y = x^2$.
3. $\iiint_V (1 + 2x^3) dx dy dz$, $V: y = 4x, y = 0, x = 1, z = \sqrt{xy}, z = 0$.
4. $x^2 + y^2 = 4x, z = 12 - y^2, z = 0$.
5. $\int_L y dl$, $L: y = x^2$ parabolaning $A(2;4)$ va $B(1;1)$ nuqtalar orasidagi yoyi.
6. $\int_L y dx - x dy$, $L: x = a \cos^3 t, y = a \sin^3 t \left(0 \leq t \leq \frac{\pi}{2}\right)$ astroida yoyi.
7. $\iint_{\sigma} (2x + 3y + z) d\sigma$, $D: 2x + 3y + z = 6$.
8. $u = x^3 + xy^2 - 6xyz$, $M_1(1;3;-5), M_2(4;2;-2)$.
9. $\vec{a} = x\vec{i} + (x+z)\vec{j} + (y+z)\vec{k}$, $D: 3x + 3y + z = 3$.
10. $\vec{a} = (y+z)\vec{i} + x\vec{j} + (x+2y)\vec{k}$, $2x + 3y + 2z = 6$.

13-variant

1. $\iint_D ye^{2xy} dx dy$, $D: y = \ln 3, y = \ln 4, x = \frac{1}{2}, x = 1$.
2. $y^2 - 6y + x^2 = 0, y^2 - 8y + x^2 = 0, y = x, x = 0$.
3. $\iiint_V (4 + 8x^3) dx dy dz$, $V: y = x, y = 0, x = 1, z = \sqrt{xy}, z = 0$.
4. $y \geq 0, z \geq 0, x = 4, y = 2x, z = x^2$.
5. $\oint_L (x - y) dl$, $L: x^2 + y^2 = 2ax$ aylana.
6. $\oint_L (x + y) dx + (x - y) dy$, $L: x = 2 \cos t, y = 3 \sin t$ ellipsning musbat yo'nalishda aylanib o'tishdagi yoyi.
7. $\iint_{\sigma} (3y - 2x - 2z) d\sigma$, $D: 2x - y - 2z = -2$.
8. $u = e^{xy+z^2}$, $M_1(-5;0;2), M_2(2;4;-3)$.
9. $\vec{a} = (2y - z)\vec{i} + (x + 2y)\vec{j} + y\vec{k}$, $D: x + 3y + 2z = 6$.
10. $\vec{a} = (x + z)\vec{i} + (z - x)\vec{j} + (x + 2y + z)\vec{k}$, $x + y + z = 2$.

14-variant

1. $\iint_D \frac{xy dx dy}{x^2 + y^2}$, $D: x^2 + y^2 = 9$.
2. $y = \frac{2}{x}$, $y = 7e^x$, $y = 2$, $y = 7$.
3. $\iiint_V xyz^2 dx dy dz$, $V: 0 \leq x \leq 2, -1 \leq y \leq 0, 0 \leq z \leq 4$.
4. $z = 32(x^2 + y^2) + 3$, $z = 3 - 64x$.
5. $\oint_L \sqrt{z^2 + y^2} dl$, $L: z^2 + y^2 = 4$ aylana.
6. $\oint_L y \cos x dx + \sin x dy$, $L: uchlari A(1;0), B(0;2), C(2;0)$ nuqtalarda bo'lgan ABC uchburchakning musbat yo'nalishda aylanib o'tishdagi konturi.
7. $\iint_\sigma (6x + y + 4z) d\sigma$, $D: 3x + 3y + z = 3$.
8. $u = xe^y + ye^x - z^2$, $M_1(3;0;2)$, $M_2(4;1;3)$.
9. $\vec{a} = (2y - z)\vec{i} + (x + y)\vec{j} + x\vec{k}$, $D: x + 2y + 2z = 4$.
10. $\vec{a} = (x + y - z)\vec{i} - 2y\vec{j} + (x + 2z)\vec{k}$, $x + 2y + z = 2$.

15-variant

1. $\iint_D (y + x^2) dx dy$, $D: y = x^2, x = y^2$.
2. $y = x^2 + 2$, $y = -3x$.
3. $\iiint_V (x^2 + y^2 + z^2) dx dy dz$, $V: 0 \leq x \leq 3, -1 \leq y \leq 2, 0 \leq z \leq 2$.
4. $z \geq 0$, $y + z = 2$, $x^2 + y^2 = 4$.
5. $\int_L (x^2 + y^2 + z^2) dl$, $L: x = 4 \cos t, y = 4 \sin t, z = 3t$ vint chizig'ining birinchi o'rami.
6. $\oint_L (x^2 - y) dx$, $L: x = 0, y = 0, x = 1, y = 2$ to'g'ri chiziqlardan tuzilgan to'g'ri to'rtburchakning musbat yo'nalishda aylanib o'tishdagi konturi.
7. $\iint_\sigma (3x + 10y - z) d\sigma$, $D: x + 3y + 2z = 6$.
8. $u = ze^{x^2 + y^2 + z^2}$, $M_1(0;0;0)$, $M_2(3;-4;2)$.
9. $\vec{a} = x\vec{i} + (y - 2z)\vec{j} + (2x - y + 2z)\vec{k}$, $D: x + 2y + 2z = 2$.
10. $\vec{a} = (2x - z)\vec{i} + (y - x)\vec{j} + (x + 2z)\vec{k}$, $x - y + z = 2$.

16-variant

1. $\iint_D xy^3 dx dy$, $D: y^2 = 1 - x, x \geq 0$.
2. $x^2 = 3y, y^2 = 3x$.
3. $\iiint_V (x + 2y) dx dy dz$, $V: z = x^2 + 3y^2, y = x, x = 1, y = 0, z = 0$.
4. $z \geq 0, y = 2, y = x, z = x^2$.
5. $\int_L y dl$, $L: x = \cos^3 t, y = \sin^3 t$ astroidaning $A(1;0)$ va $B(0;1)$ nuqtalar orasidagi yoyi.
6. $\int_L (xy - y^2) dx + x dy$, $L: y = 2x^2$ parabolaning $O(0;0)$ nuqtadan $B(1;2)$ nuqttagacha bo'lgan yoyi.
7. $\iint_\sigma (4x - y + z) d\sigma$, $D: x - y + z = 2$.
8. $u = \frac{x}{y} - \frac{y}{z} - \frac{x}{z}$, $M_1(2;2;2), M_2(-3;4;1)$.
9. $\vec{a} = (x + z)\vec{i} + (z - x)\vec{j} + (x + 2y + z)\vec{k}$, $D: x + y + z = 2$.
10. $\vec{a} = (2y - z)\vec{i} + (x + 2y)\vec{j} + y\vec{k}$, $x + 2y + 2z = 2$.

17-variant

1. $\iint_D \frac{dx dy}{\sqrt{1 + x^2 + y^2}}$, $D: x^2 + y^2 = 3$.
2. $x = y^2 + 1, y + x = 3$.
3. $\iiint_V 2xy^2 z^2 dx dy dz$, $V: 0 \leq x \leq 3, -2 \leq y \leq 0, 1 \leq z \leq 2$.
4. $z \geq 0, z = x, x = \sqrt{4 - y^2}$.
5. $\int_L \frac{dl}{x - y}$, $L: A(0;4)$ va $B(4;0)$ nuqtalarni tutashtiruvchi to'g'ri chiziq kesmasi.
6. $\oint_L x dy$, $L: x^2 + y^2 = R^2$ aylananing musbat yo'nalishda aylanib o'tishdagi yoyi.
7. $\iint_\sigma (2x - 3y + z) d\sigma$, $D: x + 2y + z = 2$.
8. $u = e^{xy}$, $M_1(3;1;4), M_2(1;-1;-1)$.
9. $\vec{a} = (y + z)\vec{i} + x\vec{j} + (y - 2z)\vec{k}$, $D: 2x + 2y + z = 2$.
10. $\vec{a} = x\vec{i} + (x + z)\vec{j} + (y + z)\vec{k}$, $3x + 3y + z = 3$.

18-variant

1. $\iint_D (y^2 + x^2) dx dy$, $D: x=1, x=y^2$.
2. $y = \frac{8}{x^2 + 4}$, $x^2 = 4y$.
3. $\iiint_V (x + 2y + 3z^2) dx dy dz$, $V: -1 \leq x \leq 2, 0 \leq y \leq 1, 1 \leq z \leq 2$.
4. $y \geq 0, z \geq 0, y + x = 2, z = x^2$.
5. $\oint_L \sqrt{x^2 + y^2} dl$, $L: x^2 + y^2 = 2x$ aylana.
6. $\int_L xye^x dx + (x-1)e^x dy$, $L: A(0;2)$ va $B(1;2)$ nuqtalarni tutashtiruvchi AB to'g'ri chiziq qismi.
7. $\iint_{\sigma} (x + 2y + 3z) d\sigma$, $D: x + y + z = 2$.
8. $u = 3xy^2 + z^2 - xyz$, $M_1(1;1;2)$, $M_2(3;-1;4)$.
9. $\vec{a} = (2z - x)\vec{i} + (x - y)\vec{j} + (3x + z)\vec{k}$, $D: x + y + 2z = 2$.
10. $\vec{a} = (x + y)\vec{i} + 3y\vec{j} + (y - z)\vec{k}$, $2x - y - 2z = -2$.

19-variant

1. $\iint_D (x^3 - 2y) dx dy$, $D: y = x^2 - 1, x \geq 0, y \leq 0$.
2. $xy = 1, x^2 = y, y = 2, x = 0$.
3. $\iiint_V \sqrt{x^2 + y^2 + z^2} dx dy dz$, $V: x^2 + y^2 + z^2 = 9, x \geq 0, y \geq 0, z \geq 0$.
4. $z = 2 - 18(x^2 + y^2), z = 2 - 36y$.
5. $\int_L \frac{dl}{\sqrt{x^2 + y^2}}$, $L: r = 2(1 + \cos \varphi) \left(0 \leq \varphi \leq \frac{\pi}{2} \right)$ kardioida.
6. $\int_L 2xy dx - x^2 dy$, $L: x = 2y^2$ parabolaning $O(0;0)$ nuqtadan $B(2;1)$ nuqtagacha bo'lgan yoyi.
7. $\iint_{\sigma} (2x + 15y + z) d\sigma$, $D: x + 2y + 2z = 2$.
8. $u = e^{x-yz}$, $M_1(1;0;3)$, $M_2(2;-4;5)$.
9. $\vec{a} = (x + 2z)\vec{i} + (y - 3z)\vec{j} + z\vec{k}$, $D: 3x + 2y + 2z = 6$.
10. $\vec{a} = (x + y + z)\vec{i} + 2z\vec{j} + (y - 7z)\vec{k}$, $2x + 3y + z = 6$.

20-variant

1. $\iint_D xy^2 dx dy$, $D: y = x^2, y = 2x$.
2. $y = 3\sqrt{x}, y = \frac{3}{x}, x = \frac{y}{12}$.
3. $\iiint_V (1+2z) dx dy dz$, $V: y = 4x, y = 0, x = 1, z = \sqrt{xy}, z = 0$.
4. $x^2 + y^2 + 4x = 0, z = 8 - y^2, z = 0$.
5. $\int_L \frac{z^2 dl}{x^2 + y^2}$, $L: x = 2 \cos t, y = 2 \sin t, z = 2t$ vint chizig'ining birinchi o'rami.
6. $\int_L (x^2 + y^2) dx + xy dy$, $L: y = e^x$ chiziqning $A(0;1)$ nuqtadan $B(1;e)$ nuqtagacha bo'lgan yoyi.
7. $\iint_\sigma (6x - y + 8z) d\sigma$, $D: x + y + 2z = 2$.
8. $u = (x^2 + y^2 + z^2)^3$, $M_1(1;2;-1), M_2(0;-1;3)$.
9. $\vec{a} = (y + 2z)\vec{i} + (x + 2z)\vec{j} + (x - 2y)\vec{k}$, $D: 2x + y + 2z = 2$.
10. $\vec{a} = (y + z)\vec{i} + (x + 6y)\vec{j} + y\vec{k}$, $x + 2y + 2z = 2$.

21-variant

1. $\iint_D x(2x + y) dx dy$, $D: y = 1 - x^2, y \geq 0$.
2. $y = \frac{2}{x}, y = 5e^x, y = 2, y = 5$.
3. $\iiint_V (x^2 + 2y^2 - z) dx dy dz$, $V: 0 \leq x \leq 1, 0 \leq y \leq 3, -1 \leq z \leq 2$.
4. $z \geq 0, z = y^2, x^2 + y^2 = 9$.
5. $\int_L y dl$, $L: y^2 = 2x$ parabolaning $A(0;0)$ va $B(1;\sqrt{2})$ nuqtalar orasidagi yoyi.
6. $\int_L 2y \sin 2x dx - \cos 2x dy$, $L: A\left(\frac{\pi}{4}; 2\right)$ va $B\left(\frac{\pi}{6}; 1\right)$ nuqtalarni tutashtiruvchi AB to'g'ri chiziq kesmasi.
7. $\iint_\sigma (5x + y - z) d\sigma$, $D: x + 2y + 2z = 2$.
8. $u = 5x^2 yz - xy^2 z + yz^2$, $M_1(1;1;1), M_2(9;-3;-9)$.
9. $\vec{a} = (x + z)\vec{i} + z\vec{j} + (2x - y)\vec{k}$, $D: 3x + 2y + z = 6$.
10. $\vec{a} = (3x - 1)\vec{i} + (y - x + z)\vec{j} + 4z\vec{k}$, $2x - y - 2z = -2$.

22-variant

1. $\iint_D \frac{dxdy}{\sqrt{x^2 + y^2}}, D: x^2 + y^2 = 4.$

2. $x^2 - 2x + y^2 = 0, x^2 - 6x + y^2 = 0, y = 0, y = x.$

3. $\iiint_V x^3 yz dx dy dz, V: -1 \leq x \leq 2, 1 \leq y \leq 3, 0 \leq z \leq 1.$

4. $z = 4 - x, x^2 + y^2 = 4x.$

5. $\int_L \frac{dl}{\sqrt{8 - x^2 - y^2}}, L: A(0;0) \text{ va } B(2;2) \text{ nuqtalarni tutashtiruvchi to'g'ri chiziq}$

kesmasi.

6. $\int_L y^2 dx + x^2 dy, L: x = 5 \cos t, y = 2 \sin t$ ellipsning musbat yo'nalishda aylanib o'tishdagi yuqori yoyi.

7. $\iint_{\sigma} (3x - 2y + 6z) d\sigma, D: 2x + y + 2z = 2.$

8. $u = (x - y)^z, M_1(1;5;0), M_2(3;7;-2).$

9. $\vec{a} = 4x\vec{i} + (x - y - z)\vec{j} + (3y + 2z)\vec{k}, D: 2x + y + z = 4.$

10. $\vec{a} = (2y + z)\vec{i} + (x - y)\vec{j} - 2z\vec{k}, x - y + z = 2.$

23-variant

1. $\iint_D e^{x^2+y^2} \sqrt{x^2 + y^2} dx dy, D: x^2 + y^2 = 9.$

2. $x = y^2, x = \sqrt{2 - y^2}.$

3. $\iiint_V 3(2y + 3x) dx dy dz, V: y = x, x = 0, x = 1, z = x^2 + y^2, z = 0.$

4. $z = 0, x^2 + y^2 = 4y, z = 4 - x^2.$

5. $\int_L \frac{dl}{x^2 + y^2 + z^2}, L: x = \cos t, y = \sin t, z = t$ vint chizig'ining birinchi o'rami.

6. $\int_L 2xy dx - x^2 dy + z dz, L: O(0;0;0) \text{ va } B(2;1;-1) \text{ nuqtalarni tutashtiruvchi } OB$
to'g'ri chiziq kesmasi.

7. $\iint_{\sigma} (2x + 5y + 10z) d\sigma, D: 2x + y + 3z = 6.$

8. $u = \frac{x}{x^2 + y^2 + z^2}, M_1(1;2;2), M_2(-3;2;-1).$

9. $\vec{a} = (x + z)\vec{i} + 2y\vec{j} + (x + y - z)\vec{k}, D: x + 2y + z = 2.$

10. $\vec{a} = (x + y)\vec{i} + (y + z)\vec{j} + 2(x + z)\vec{k}, 3x - 2y + 2z = 6.$

24-variant

1. $\iint_D (x+1)y^2 dx dy$, $D: y=3x^2, y=3$.
2. $x=\sqrt{4-y^2}, y=\sqrt{3x}$.
3. $\iiint_V (x+y+z) dx dy dz$, $V: x+y+z=1, x \geq 0, y \geq 0, z \geq 0$.
4. $z=24(x^2+y^2), z=48x$.
5. $\int_L (x^2+y^2)^2 dl$, $L: x=3\cos t, y=3\sin t$ aylana.
6. $\int_L (2a-y)dx + xdy$, $L: x=a(t-\sin t), y=a(1-\cos t)$ ($0 \leq t \leq 2\pi$) sikloidaning birinchi arkasi.
7. $\iint_\sigma (3x+2y+2z)d\sigma$, $D: 3x+2y+2z=6$.
8. $u=x^3y+y^3z-3z^2$, $M_1(0;-2;-1), M_2(12;-5;0)$.
9. $\vec{a}=(x+z)\vec{i}+(x+3y)\vec{j}+y\vec{k}$, $D: 2x+2y+z=4$.
10. $\vec{a}=(y+z)\vec{i}+(2x-z)\vec{j}+(y+3z)\vec{k}$, $2x+y+3z=6$.

25-variant

1. $\iint_D \frac{y^2}{x^2} dx dy$, $D: y=x, xy=1, y=2$.
2. $2y=\sqrt{x}, x+y=5$.
3. $\iiint_V x^2y^2z^3 dx dy dz$, $V: -1 \leq x \leq 3, 0 \leq y \leq 2, 1 \leq z \leq 2$.
4. $x^2+y^2=3z, x+y=6$.
5. $\int_L (4\sqrt[3]{x}-3\sqrt[3]{y})dl$, $L: x=\cos^3 t, y=\sin^3 t$ astroidaning $A(1;0)$ va $B(0;1)$ nuqtalar orasidagi yoyi.
6. $\int_L \sin y dx + \sin x dy$, $L: A(0;\pi)$ va $B(\pi;0)$ nuqtalarni tutashtiruvchi AB to'g'ri chiziq kesmasi.
7. $\iint_\sigma (x+2y+3z)d\sigma$, $D: 2x-y+z=2$.
8. $u=3xy^2z^3$, $M_1(-3;-2;1), M_2(0;1;-3)$.
9. $\vec{a}=4z\vec{i}+(x-y-z)\vec{j}+(3y+z)\vec{k}$, $D: x-2y+2z=2$.
10. $\vec{a}=(2z-x)\vec{i}+(x+2y)\vec{j}+3z\vec{k}$, $x+4y+2z=8$.

26-variant

1. $\iint_D x^2(1+3y)dxdy$, $D: x=0, y^2=2-x$.
2. $y+2x=0, x^2=3-y$.
3. $\iiint_V (x^2+y^2+z^2)dxdydz$, $V: 0 \leq x \leq 1, -2 \leq y \leq 1, 1 \leq z \leq 3$.
4. $x^2+y^2=2x, z=\frac{13}{4}-y^2, z=0$.
5. $\int_L xdl$, $L: x=\cos^3 t, y=\sin^3 t$ astroidaning $A(1;0)$ va $B(0;1)$ nuqtalar orasidagi yoyi.
6. $\int_L (xy-2)dx+y^2xdy$, $L: A(2;1)$ va $B(1;2)$ nuqtalarni tutashtiruvchi AB to'g'ri chiziq kesmasi.
7. $\iint_\sigma (3x-y+2z)d\sigma$, $D: x+2y+z=4$.
8. $u=xe^{x^2+y^2+z^2}$, $M_1(0;0;0)$, $M_2(2;-4;3)$.
9. $\vec{a}=(x+y)\vec{i}+(x+z)\vec{j}+2(y+z)\vec{k}$, $D: 2x-3y+2z=6$.
10. $\vec{a}=(x+y)\vec{i}+(x+3z)\vec{j}+z\vec{k}$, $2x+y+2z=2$.

27-variant

1. $\iint_D (x+y^2)dxdy$, $D: y=x^2, x=y^2$.
2. $xy=2, x=5e^y, x=2, x=5$.
3. $\iiint_V 8x^2yz^2dxdydz$, $V: -2 \leq x \leq 1, 0 \leq y \leq 2, -1 \leq z \leq 3$.
4. $z=10-x^2, z=0, x^2+y^2=4y$.
5. $\oint_L (x+y)dl$, $L: x^2+y^2=2ay$ aylana.
6. $\int_L ydx$, $L: y=\cos x$ cosinusoidaning $O(\pi;-1)$ nuqtadan $B(0;1)$ nuqtagacha bo'lgan yoyi.
7. $\iint_\sigma (3x-2y+z)d\sigma$, $D: 2x+y+z=4$.
8. $u=3yx^2+z^2-xyz$, $M_1(1;1;2)$, $M_2(-1;3;4)$.
9. $\vec{a}=(x+y+z)\vec{i}+2z\vec{j}+(x-7z)\vec{k}$, $D: 3x+2y+z=6$.
10. $\vec{a}=y\vec{i}+(x-2z)\vec{j}+(2y-x+2z)\vec{k}$, $2x+y+2z=2$.

28-variant

1. $\iint_D \frac{dxdy}{\sqrt{1+x^2+y^2}}, D: x^2+y^2=8.$

2. $y = \frac{2}{x^2+1}, x^2 = y.$

3. $\iiint_V (2+3y^3)dxdydz, V: x=4y, x=0, y=1, z=\sqrt{xy}, z=0.$

4. $z \geq 0, y^2+x^2=4, z=x^2.$

5. $\oint_L \sqrt{x^2+y^2} dl, L: x^2+y^2=4x$ aylana.

6. $\oint_L (x-y)dx + (x+y)dy, L: x=3\cos t, y=2\sin t$ ellipsning musbat

yoʻnalishda aylanib oʻtishdagi yoyi.

7. $\iint_{\sigma} (x+6y+4z)d\sigma, D: 2x+2y+z=2.$

8. $u = x^2y + xz^2 + zy^2, M_1(1;1;1), M_2(-1;0;2).$

9. $\vec{a} = (2x-z)\vec{i} + (x+y)\vec{j} + y\vec{k}, D: 2x+y+2z=4.$

10. $\vec{a} = (2x-z)\vec{i} + (z-y)\vec{j} + (x+3z)\vec{k}, 2x+y+z=2.$

29-variant

1. $\iint_D \frac{xydxdy}{x^2+y^2}, D: x^2+y^2=16.$

2. $x^2+y^2=4, x^2=3y.$

3. $\iiint_V (x^2+2y+z^2)dxdydz, V: 1 \leq x \leq 2, 0 \leq y \leq 2, -1 \leq z \leq 2.$

4. $z=4-y, x^2+y^2=4y.$

5. $\int_L \frac{dl}{y-x}, L: A(1;3)$ va $B(3;1)$ nuqtalarni tutashtiruvchi toʻgʻri chiziq

kesmasi.

6. $\oint_L ydx, L: x^2+y^2=16$ aylananing musbat yoʻnalishda aylanib oʻtishdagi

yoyi.

7. $\iint_{\sigma} (4x+y+2z)d\sigma, D: x+y+z=1.$

8. $u = \frac{1}{2}x^2y^2z^2, M_1(1;-1;0), M_2(2;-1;2).$

9. $\vec{a} = (2x+z)\vec{i} + (y-2z)\vec{j} + x\vec{k}, D: 2x+2y+3z=6.$

10. $\vec{a} = (x+z)\vec{i} + y\vec{j} + (y+2x)\vec{k}, 3x+2y+2z=6.$

30-variant

1. $\iint_D (x^2 + 3y) dx dy$, $D: x + y = 1, y = x^2 - 1, x \geq 0$.
2. $y^2 = 4x, x^2 = 4y$.
3. $\iiint_V (3x^2 + 2y + z) dx dy dz$, $V: 0 \leq x \leq 1, 0 \leq y \leq 1, -1 \leq z \leq 3$.
4. $x = 1, y = 2x, y \geq 0, z = y^2, z \geq 0$.
5. $\int_L \sqrt{2y} dl$, $L: x = 2(t - \sin t), y = 2(1 - \cos t)$ sikloidaning bir arkasi.
6. $\int_L y^2 dx + x^2 dy$, $L: x = a \cos t, y = b \sin t$ ellipsning soat strelkasi yo'nalishida aylanib o'tishdagi yoyi.
7. $\iint_{\sigma} (4x - y + 4z) d\sigma$, $D: 2x + 2y + z = 4$.
8. $u = \ln(1 + x + y^2)$, $M_1(1;1;1), M_2(3;-5;4)$.
9. $\vec{a} = (2z - x)\vec{i} + (x + 2y)\vec{j} + 3z\vec{k}$, $D: x + 4y + 2z = 8$.
10. $\vec{a} = z\vec{i} + (x + y)\vec{j} + y\vec{k}$, $2x + y + 2z = 2$.

NAMUNAVIY VARIANT YECHIMI

1. Ikki karrali integralni hisoblang.

1.30. $\iint_D (x^2 + 3y) dx dy$, $D: x + y = 1, y = x^2 - 1, x \geq 0$.

\odot D integrallash sohasi 18 - shaklda keltirilgan.

Agar ichki integrallash y bo'yicha va tashqi integrallash x bo'yicha bajarilsa berilgan ikki karrali integral bitta takroriy integral bilan ifodalanadi. Integralni hisoblaymiz:

$$\begin{aligned} \iint_D (x^2 + 3y) dx dy &= \int_0^1 dx \int_{x^2-1}^{1-x} (x^2 + 3y) dy = \int_0^1 \left(x^2 y + \frac{3}{2} y^2 \right) \Big|_{x^2-1}^{1-x} dx = \\ &= \int_0^1 \left(x^2 - x^3 - x^4 + x^2 + \frac{3}{2} (1 - 2x + x^2 - x^4 + 2x^2 - 1) \right) dx = \\ &= \frac{1}{2} \int_0^1 (4x^2 - 2x^3 - 2x^4 + 9x^2 - 3x^4 - 6x) dx = \end{aligned}$$

$$= \frac{1}{2} \int_0^1 (13x^2 - 2x^3 - 5x^4 - 6x) dx = \frac{1}{2} \left(\frac{13}{3} x^3 - \frac{1}{2} x^4 - x^5 - 3x^2 \right) \Big|_0^1 = -\frac{1}{12}. \quad \odot$$

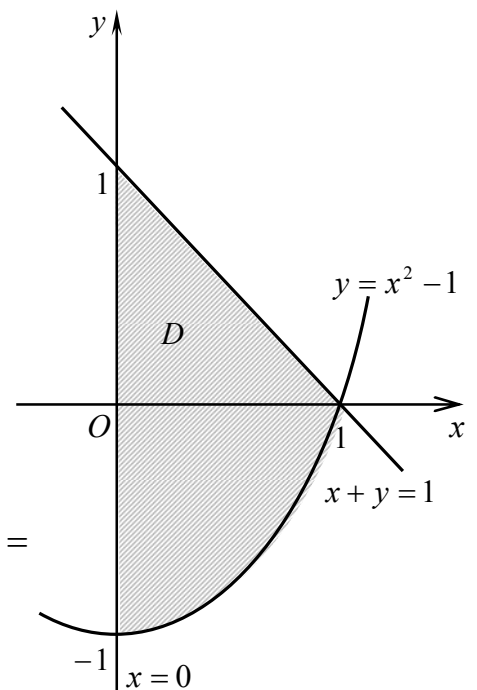

18-shakl.

2. Berilgan chiziqlar bilan chegaralangan D tekis shakl yuzasini toping.

2.30. $y^2 = 4x, x^2 = 4y.$

☞ Tekis shakl quyidan $y = \frac{1}{4}x^2$ parabola bilan yuqoridan $y^2 = 4x$ parabola bilan chegaralangan (19-shakl).

Bundan

$$S = \iint_D dx dy = \int_0^4 dx \int_{\frac{1}{4}x^2}^{2\sqrt{x}} dy = \int_0^4 \left(2\sqrt{x} - \frac{1}{4}x^2 \right) dx = \left(\frac{4}{3}x^{\frac{3}{2}} - \frac{1}{12}x^3 \right) \Big|_0^4 = \frac{16}{3}. \quad \text{☞}$$

3. Uch karrali integrallarni hisoblang.

3.30. $\iiint_V (3x^2 + 2y + z) dx dy dz, V: 0 \leq x \leq 1, 0 \leq y \leq 1, -1 \leq z \leq 3.$

☞ Berilgan to‘g‘ri burchakli parallelepiped uchun topamiz:

$$\begin{aligned} \iiint_V (3x^2 + 2y + z) dx dy dz &= \int_0^1 dx \int_0^1 dy \int_{-1}^3 (3x^2 + 2y + z) dz = \\ &= \int_0^1 dx \int_0^1 \left((3x^2 + 2y)z + \frac{z^2}{2} \right) \Big|_{-1}^3 dy = 4 \int_0^1 dx \int_0^1 (3x^2 + 2y + 1) dy = \\ &= 4 \int_0^1 ((3x^2 + 1)y + y^2) \Big|_0^1 dx = 4 \int_0^1 (3x^2 + 2) dx = 4(x^3 + 2x) \Big|_0^1 = 12. \quad \text{☞} \end{aligned}$$

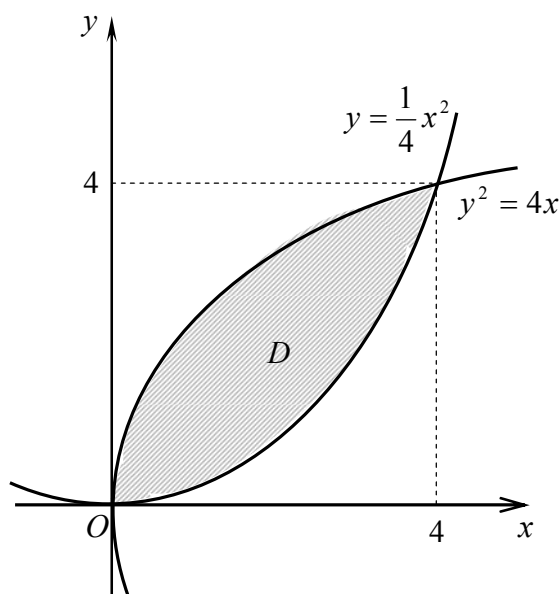

19-shakl.

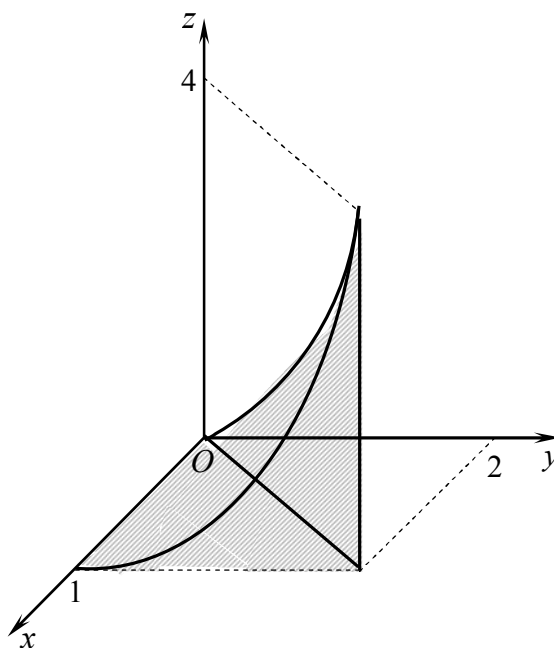

20-shakl.

4. Berilgan sirtlar bilan chegaralangan jismning hajmini uch karrali integral bilan toping.

4.30. $x=1, y=2x, y \geq 0, z=y^2, z \geq 0.$

☞ Berilgan jism (20- shakl) hajmini hisoblaymiz:

$$V = \iiint_V dx dy dz = \int_0^1 dx \int_0^{2x} dy \int_0^{y^2} dz = \int_0^1 dx \int_0^{2x} z \Big|_0^{y^2} dy = \int_0^1 dx \int_0^{2x} y^2 dy = \int_0^1 \frac{y^3}{3} \Big|_0^{2x} dy = \frac{8}{3} \int_0^1 x^3 dx = \frac{2}{3} x^4 \Big|_0^1 = \frac{2}{3}. \quad \text{☞}$$

5. Birinchi tur egri chiziqli integralni hisoblang.

5.30. $\int_L \sqrt{2y} dl, L: x=2(t-\sin t), y=2(1-\cos t)$ sikloidaning bir arkasi.

☞ Sikloidaning parametrik tenglamasidan topamiz:

$$x'_t = 2(1 - \cos t), y'_t = 2 \sin t,$$

$$dl = \sqrt{4(1 - \cos t)^2 + 4 \sin^2 t} dt = 2\sqrt{2} \sqrt{1 - \cos t} dt.$$

U holda

$$\begin{aligned} \int_L \sqrt{2y} dl &= \int_0^{2\pi} \sqrt{2 \cdot 2(1 - \cos t)} 2\sqrt{2} \sqrt{1 - \cos t} dt = \\ &= 4\sqrt{2} \int_0^{2\pi} (1 - \cos t) dt = 4\sqrt{2} (t - \sin t) \Big|_0^{2\pi} = 8\pi\sqrt{2}. \quad \text{☞} \end{aligned}$$

6. Ikkinchi tur egri chiziqli integrallarni hisoblang.

6.30. $\int_L y^2 dx + x^2 dy, L: x = a \cos t, y = b \sin t$ ellipsning soat strelkasi

yo‘nalishida aylanib o‘tishdagi yuqori yoyi.

☞ Ellipsning parametrik tenglamasiga ko‘ra $dx = -a \sin t dt, dy = b \cos t dt.$

Bunda soat strelkasi yo‘nalishida t parametr π dan 0 gacha o‘zgaradi.

U holda

$$\begin{aligned} \int_L y^2 dx + x^2 dy &= \int_{\pi}^0 (-b^2 \sin^2 t a \cos t + a^2 \cos^2 t b \sin t) dt = \\ &= \int_{\pi}^0 b^2 a (1 - \cos^2 t) d(\cos t) + \int_{\pi}^0 a^2 b (1 - \sin^2 t) d(\sin t) = \\ &= b^2 a \left(\cos t - \frac{1}{3} \cos^3 t \right) \Big|_{\pi}^0 + a^2 b \left(\sin t - \frac{1}{3} \sin^3 t \right) \Big|_{\pi}^0 = \frac{4}{3} ab^2. \end{aligned}$$

7. Birinchi tur sirt integralini hisoblang, bu yerda $\sigma - D$ tekislikning koordinata tekisliklari bilan ajratilgan qismi.

7.30. $\iint_{\sigma} (4x - y + 4z) d\sigma, D: 2x + 2y + z = 4.$

☞ Tekislik tenglamasidan topamiz:

$$z = 4 - 2x - 2y, z'_x = -2, z'_y = -2.$$

U holda $d\sigma = \sqrt{1 + z_x'^2 + z_y'^2} dx dy = 3 dx dy$.

Sirt integralini σ_{xy} soha bo'yicha ikki karrali integralni hisoblashga keltiramiz, bu yerda $\sigma_{xy} - \sigma$ sirtning Oxy tekislikdagi proeksiyasi bo'lgan AOB uchburchak (21-shakl).

$$\begin{aligned} \iint_{\sigma} (4x - y + 4z) d\sigma &= \iint_{\sigma} (4x - y + 16 - 8x - 8y) 3 dx dy = \\ &= 3 \int_0^2 dx \int_0^{2-x} (16 - 4x - 9y) dy = 3 \int_0^2 \left((16 - 4x)y - \frac{9}{2} y^2 \right) \Big|_0^{2-x} dx = \\ &= 3 \int_0^2 (2-x) \left((16 - 4x) - \frac{9(2-x)}{2} \right) dx = \\ &= \frac{3}{2} \int_0^2 (2-x)(x+14) dx = \\ &= \frac{3}{2} \int_0^2 (28 - 12x - x^2) dx = \frac{3}{2} \left(28x - 6x^2 - \frac{x^3}{3} \right) \Big|_0^2 = 44. \end{aligned}$$

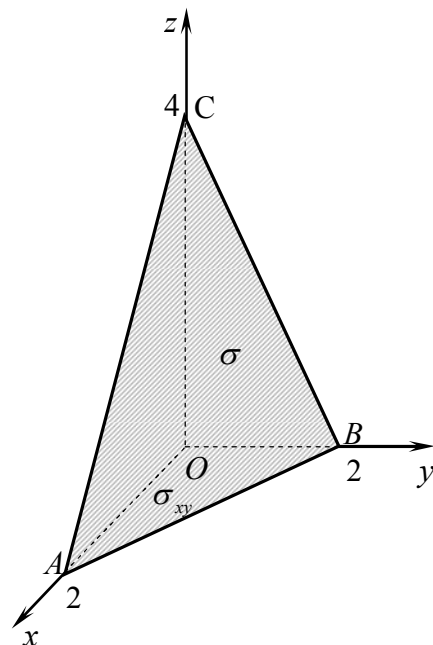

21-shakl.

8. $u = u(x, y, z)$ funksiyaning M_1 nuqtadagi $\overline{M_1 M_2}$ vektor yo'nalishidagi hosilasini toping.

8.30. $u = \ln(1 + x + y^2 + z^2)$, $M_1(1;1;1)$, $M_2(3;-5;4)$.

☞ $\overline{M_1 M_2}$ vektor yo'nalishidagi \vec{l} birlik vektorning yo'naltiruvchi kosinuslarini topamiz:

$$\begin{aligned} \overline{M_1 M_2} &= \{2; -6; 3\}, \quad \vec{l}^0 = \frac{\overline{M_1 M_2}}{|\overline{M_1 M_2}|} = \frac{2\vec{i} - 6\vec{j} + 3\vec{k}}{7} = \frac{2}{7}\vec{i} - \frac{6}{7}\vec{j} + \frac{3}{7}\vec{k}, \\ \cos \alpha &= \frac{2}{7}, \quad \cos \beta = -\frac{6}{7}, \quad \cos \gamma = \frac{3}{7}. \end{aligned}$$

$u = \ln(1 + x + y^2 + z^2)$ funksiya xususiy hosilalarining $M_1(1;1;1)$ nuqtadagi qiymatlarini topamiz:

$$\begin{aligned} \left. \frac{\partial u}{\partial x} \right|_{M_0} &= \frac{1}{1 + x + y^2 + z^2} \Big|_{M_0} = \frac{1}{4}, \quad \left. \frac{\partial u}{\partial y} \right|_{M_0} = \frac{2y}{1 + x + y^2 + z^2} \Big|_{M_0} = \frac{1}{2}, \\ \left. \frac{\partial u}{\partial z} \right|_{M_0} &= \frac{2z}{1 + x + y^2 + z^2} \Big|_{M_0} = \frac{1}{2}. \end{aligned}$$

U holda

$$\frac{\partial u}{\partial l} = \frac{1}{4} \cdot \frac{2}{7} + \frac{1}{2} \cdot \left(-\frac{6}{7} \right) + \frac{1}{2} \cdot \frac{3}{7} = -\frac{1}{7}. \quad \text{☞}$$

9. \vec{a} vektor maydon oqimini

D tekislik va koordinata tekisliklaridan hosil bo'lgan piramidaning tashqi sirti bo'yicha ikki usul bilan hisoblang:

- 1) oqim ta'rifidan foydalanib;
- 2) Ostrogradskiy-Gauss formulasi orqali.

9.30. $\vec{a} = (2z - x)\vec{i} + (x + 2y)\vec{j} + 3z\vec{k}$,

$D: x + 4y + 2z = 8$.

1) Vektor maydon oqimini $\Pi = \iint_{\sigma} \vec{a}\vec{n}^0 d\sigma$ formula bilan piramidaning (22-shakl) har bir tomoni (to'rtta uchburchak) orqali hisoblaymiz:

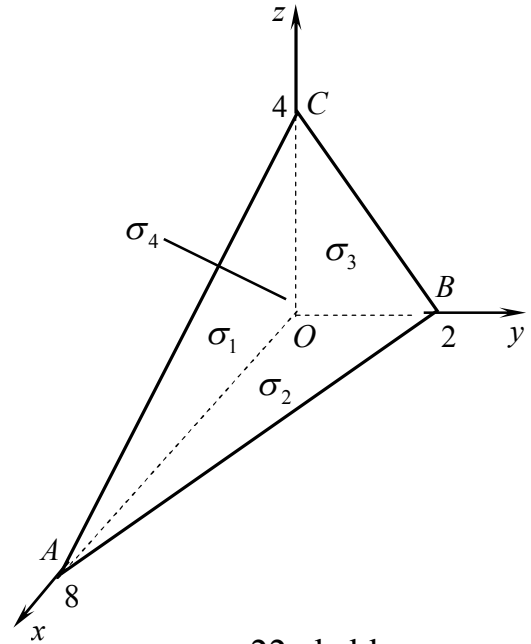

22-shakl.

ΔAOC da $y=0$, $\vec{n}^0 = -\vec{j}$, $x + 2z = 8$.

$$\begin{aligned} \Pi_1 &= -\iint_{\sigma} x d\sigma = -\iint_{\sigma_1} x dx dz = -\int_0^4 dz \int_0^{2(4-z)} x dx = -\frac{1}{2} \int_0^4 x^2 \Big|_0^{2(4-x)} dz = \\ &= -2 \int_0^4 (16 - 8z + z^2) dz = -2 \left(16z - 4z^2 + \frac{z^3}{3} \right) \Big|_0^4 = -\frac{128}{3}. \end{aligned}$$

ΔAOB da $z=0$, $\vec{n}^0 = -\vec{k}$, $x + 4y = 8$.

$$\Pi_2 = \iint_{\sigma} 0 d\sigma = 0.$$

ΔBOC da $x=0$, $\vec{n}^0 = -\vec{i}$, $z + 2y = 4$.

$$\begin{aligned} \Pi_3 &= -\iint_{\sigma} 2z d\sigma = -\iint_{\sigma_3} 2z dy dz = -\int_0^2 dy \int_0^{2(2-y)} 2z dz = -\int_0^2 z^2 \Big|_0^{2(2-y)} dy = \\ &= -4 \int_0^2 (4 - 4y + y^2) dy = -4 \left(4y - 2y^2 + \frac{y^3}{3} \right) \Big|_0^2 = -\frac{32}{3}. \end{aligned}$$

ΔABC da $\vec{n}^0 = \frac{\vec{i} + 4\vec{j} + 2\vec{k}}{\sqrt{21}}$, $z = \frac{8-x-4y}{2}$, $z'_x = -\frac{1}{2}$, $z'_y = -2$,

$$d\sigma = \sqrt{1 + z'^2_x + z'^2_y} dx dy = \sqrt{1 + \frac{1}{4} + 4} dx dy = \frac{\sqrt{21}}{2} dx dy,$$

$$\vec{a}\vec{n}^0 = \frac{1}{\sqrt{21}} (2z - x + 4(x + 2y) + 2 \cdot 3z) = \frac{8z + 3x + 8y}{\sqrt{21}}.$$

$$\Pi_4 = -\frac{1}{\sqrt{21}} \iint_{\sigma} (3x + 8y + 8z) d\sigma = \frac{1}{\sqrt{21}} \cdot \frac{\sqrt{21}}{2} \iint_{\sigma_4} (3x + 8y + 32 - 4x - 16y) dx dy =$$

$$\begin{aligned}
&= \frac{1}{2} \iint_{D_4} (32 - x - 8y) dx dy = \frac{1}{2} \int_0^2 dy \int_0^{4(2-y)} (32 - x - 8y) dx = \\
&= \frac{1}{2} \int_0^2 \left((32 - 8y)x - \frac{x^2}{2} \right) \Big|_0^{4(2-y)} dy = \frac{1}{2} \cdot 8 \int_0^2 ((16 - 4y)(2 - y) - (2 - y)^2) dy = \\
&= 4 \int_0^2 (2 - y)(16 - 4y - 2 + y) dy = 4 \int_0^2 (2 - y)(14 - 3y) dy = \\
&= 4 \int_0^2 (28 - 20y + 3y^2) dy = 4(28y - 10y^2 + y^3) \Big|_0^2 = 96.
\end{aligned}$$

Demak,

$$\Pi = \Pi_1 + \Pi_2 + \Pi_3 + \Pi_4 = -\frac{128}{3} + 0 - \frac{32}{3} + 96 = \frac{128}{3}.$$

2) Vektor maydon oqimini Ostrogradskiy-Gauss formulasi orqali hisoblaymiz.

$$\begin{aligned}
\Pi &= \iiint_V \left(\frac{\partial P}{\partial x} + \frac{\partial Q}{\partial y} + \frac{\partial R}{\partial z} \right) dx dy dz = \iiint_V (-1 + 2 + 3) dx dy dz = \\
&= 4 \int_0^2 dy \int_0^{4(2-y)} dx \int_0^{\frac{8-x-4y}{2}} dz = 4 \int_0^2 dy \int_0^{4(2-y)} z \Big|_0^{\frac{8-x-4y}{2}} dx = 2 \int_0^2 dy \int_0^{4(2-y)} (8 - 4y - x) dx = \\
&= 2 \int_0^2 \left((8 - 4y)x - \frac{x^2}{2} \right) \Big|_0^{4(2-y)} dy = 16 \int_0^2 (2 - y)(4 - 2y - 2 + y) dy = \\
&= 16 \int_0^2 (4 - 4y + y^2) dy = 16 \left(4y - 2y^2 + \frac{y^3}{3} \right) \Big|_0^2 = \frac{128}{3}. \quad \blacktriangleleft
\end{aligned}$$

10. \vec{a} vektor maydon sirkulatsiyasini tekislikning koordinata tekisliklari bilan kesishishidan hosil bo'lgan uchburchakning $\vec{n} = \{A; B; C\}$ vektorga nisbatan musbat yo'nalishda aylanish konturi bo'yicha ikki usul bilan hisoblang: 1) sirkulatsiya ta'rifidan foydalanib; 2) Stoks formulasi orqali.

10.30. $\vec{a} = z\vec{i} + (x + y)\vec{j} + y\vec{k}$, $2x + y + 2z = 2$.

☞ 1) Sirkulatsiyani $ABCA$ kontur (23-shakl) bo'yicha topamiz:

$$\Pi = \oint_L \vec{a} d\vec{r} = \int_{AB} \vec{a} d\vec{r} + \int_{BC} \vec{a} d\vec{r} + \int_{CA} \vec{a} d\vec{r}.$$

AB kesmada $z = 0$, $dz = 0$, $2x + y = 2$, $y = 2(1 - x)$, $dy = -2dx$. U holda

$$\vec{a} = (x + y)\vec{j} + y\vec{k}, \quad d\vec{r} = dx\vec{i} + dy\vec{j}, \quad \vec{a} d\vec{r} = (x + y)dy.$$

Bundan

$$\Pi_1 = \int_{AB} \vec{a} d\vec{r} = \int_{AB} (x + y)dy = -2 \int_1^0 (x + 2 - 2x)dx = -2 \int_1^0 (2 - x)dx = -2 \left(2x - \frac{x^2}{2} \right) \Big|_1^0 = 3.$$

BC kesmada $x=0$, $dx=0$, $2z+y=2$, $z=\frac{2-y}{2}$, $dz=-\frac{1}{2}dy$.

U holda $\vec{a} = z\vec{i} + y\vec{j} + y\vec{k}$, $d\vec{r} = dy\vec{j} + dz\vec{k}$, $\vec{a}d\vec{r} = ydy + ydz$.

Bundan

$$U_2 = \int_{BC} \vec{a}d\vec{r} = \int_{BC} ydy + ydz = \int_2^0 \left(y - \frac{1}{2}y \right) dy = \frac{1}{2} \frac{y^2}{2} \Big|_2^0 = -1.$$

CA kesmada $y=0$, $dy=0$, $x+z=1$, $z=1-x$, $dz=-dx$.

U holda $\vec{a} = z\vec{i} + x\vec{j}$, $d\vec{r} = dx\vec{i} + dz\vec{k}$, $\vec{a}d\vec{r} = zdx$.

Bundan

$$U_3 = \int_{CA} \vec{a}d\vec{r} = \int_{CA} zdx = \int_0^1 (1-x)dx = \left(x - \frac{x^2}{2} \right) \Big|_0^1 = \frac{1}{2}.$$

Demak,

$$U = U_1 + U_2 + U_3 = 3 - 1 + \frac{1}{2} = \frac{5}{2}.$$

2) Sirkulyatsiyani Stoks formulasidan foydalanib topamiz:

$\vec{a} = z\vec{i} + (x+y)\vec{j} + y\vec{k}$ dan

$P = z$, $Q = x + y$, $R = y$.

Bundan

$$\frac{\partial R}{\partial y} - \frac{\partial Q}{\partial z} = 1, \quad \frac{\partial P}{\partial z} - \frac{\partial R}{\partial x} = 1,$$

$$\frac{\partial Q}{\partial x} - \frac{\partial P}{\partial y} = 1.$$

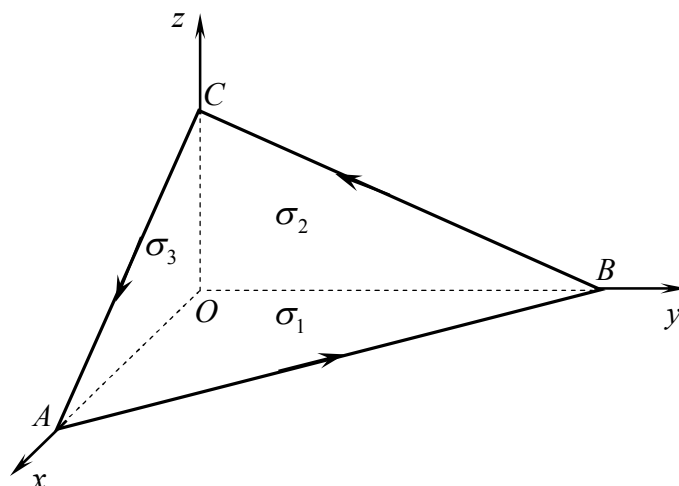

23-shakl.

U holda

$$\begin{aligned} U &= \iint_{\sigma} \text{rot} \vec{a} d\vec{\sigma} = \iint_{\sigma} dydz + dzdx + dxdy = \iint_{D_1} dydz + \iint_{D_2} dzdx + \iint_{D_3} dxdy = \\ &= \int_0^1 dz \int_0^{2(1-z)} dy + \int_0^1 dx \int_0^{1-x} dz + \int_0^1 dx \int_0^{2(1-x)} dy = \int_0^1 (2-2z)dz + \int_0^1 (1-x)dx + \int_0^1 (2-2x)dx = \\ &= (2z - z^2) \Big|_0^1 + \left(x - \frac{x^2}{2} \right) \Big|_0^1 + (2x - x^2) \Big|_0^1 = 1 + \frac{1}{2} + 1 = \frac{5}{2}. \end{aligned}$$

III bob

ODDIY DIFFERENSIAL TENGLAMALAR

3.1. BIRINCHI TARTIBLI DIFFERENSIAL TENGLAMALAR

**Asosiy tushunchalar. Kvadraturada integrallanuvchi
birinchi tartibli differensial tenglamalar.
Hosilada nisbatan yechilmagan differensial tenglamalar.**

3.1.1.  Erkli o'zgaruvchi, noma'lum funksiya va uning hosilalarini (differensiallarini) bog'lovchi tenglamaga *differensial tenglama* deyiladi.

Noma'lum funksiyasi bitta o'zgaruvchiga bog'liq bo'lgan differensial tenglama *oddiy differensial tenglama* deb ataladi.

Differensial tenglamaga kiruvchi hosilalarning (differensiallarning) eng yuqori tartibiga differensial tenglamaning *tartibi* deyiladi.

Birinchi tartibli oddiy differensial tenglama umumiy ko'rinishda

$$F(x, y, y') = 0 \tag{1.1}$$

kabi yoziladi, bu yerda x – erkli o'zgaruvchi, y – noma'lum funksiya, y' – noma'lum funksiyaning hosilasi, F – ikki o'lchamli R^2 sohada ikki o'zgaruvchili funksiya.

Agar (1.1) tenglamani y' ga nisbatan yechish mumkin bo'lsa, tenglama

$$y' = f(x, y) \tag{1.2}$$

ko'rinishda ifodalanadi, bu yerda f – berilgan funksiya. Bu tenglamadan differensiallar ishtirok etuvchi simmetrik shakl deb ataluvchi

$$M(x, y)dx + N(x, y)dy = 0$$

tenglamaga o'tish mumkin.

(1.1) differensial tenglamaning *yechimi (integrali)* deb, tenglamaga qo'yganda uni ayniyatga aylantiradigan differensiallanuvchi $y = \varphi(x)$ funksiyaga aytiladi.

(1.2) differensial tenglamaning *umumiy yechimi* deb, quyidagi shartlarni qanoatlantiruvchi $y = \varphi(x, C)$ (bu yerda C – ixtiyoriy o'zgarmas) funksiyaga aytiladi:

a) y ixtiyoriy o'zgarmasning istalgan qiymatida (1.2) differensial tenglamani qanoatlantiradi;

b) boshlang'ich $y|_{x=x_0} = y_0$ shart har qanday bo'lganda ham ixtiyoriy o'zgarmasning shunday \bar{C} qiymatini topish mumkinki, $y = \varphi(x, \bar{C})$ yechim boshlang'ich shartni qanoatlantiradi, ya'ni $y_0 = \varphi(x_0, \bar{C})$ bo'ladi.

(1.2) differensial tenglamaning umumiy yechimidan ixtiyoriy o'zgarmasning tayin qiymatida hosil bo'ladigan har qanday yechimga *xususiy yechim* deyiladi.

Differensial tenglama yechimining grafigi *integral egri chiziq* deb ataladi. (1.2) differensial tenglama integral egri chiziqning har bir $M(x, y)$ nuqtasida bu egri chiziqqa o'tkazilgan urinmaning yo'nalishini aniqlaydi. Tekislikning har bir nuqtasiga $tg\alpha = f(x, y)$ tenglik bajariladigan qilib kesma qo'yilgan qismi (1.2) differensial tenglamaning *yo'nalishlar maydoni* deyiladi. Shunday qilib, (1.2) differensial tenglamaga uning yo'nalishlar maydoni mos keladi. Bu jumla (1.2) differensial tenglamaning *geometrik ma'nosini* bildiradi.

Differensial tenglamada uning umumiy yechimidan ixtiyoriy o'zgarmasning hech bir qiymatida hosil qilinishi mumkin bo'lmagan yechim *maxsus yechim* deb ataladi.

Maxsus yechimning grafigi umumiy yechimga kirgan integral egri chiziqlarning o'ramasi deb ataluvchi chiziqdan iborat bo'ladi va u

$$\begin{cases} \Phi(x, y, C) = 0, \\ \Phi'_c(x, y, C) = 0 \end{cases}$$

sistemadan C ni yo'qotish orqali topiladi. Bunda hosil bo'lgan $y = g(x)$ funksiya (1.1) differensial tenglamani qanoatlantirishi va $\Phi(x, y, C) = 0$ oilaga kirmasligi kerak.

Matematika, fizika, kimyo va boshqa fanlarning turli masalalari differensial tenglamalar ko'rinishidagi matematik modellarga keltiriladi.

1-misol. Massasi m ga teng moddiy nuqta v tezlikning kvadratiga proporsional bo'lgan muhit qarshilik kuchi ta'sirida harakatini sekinlatmoqda. Nuqta harakat qonunining tenglamasini tuzing.

☉ Erkli o'zgaruvchi sifatida moddiy nuqtaning sekinlashish boshlanishidan hisoblanuvchi t vaqtni olamiz. U holda nuqtaning v tezligi t vaqtning funksiyasi bo'ladi, ya'ni $v = v(t)$.

Moddiy nuqtaning harakat qonunini topish uchun Nyutonning ikkinchi qonunidan foydalanamiz: $m \cdot a = F$, bu yerda $a = v'(t)$ – harakatlanuvchi jism tezlanishi, F – jismga harakat jarayonida ta'sir qiluvchi kuchlar yig'indisi.

Bu masalada $F = -kv^2$, bu yerda $k > 0$ –proporsionallik koeffitsiyenti (minus ishora harakatning sekinlashishini bildiradi).

Shunday qilib, moddiy nuqtaning harakat qonuni

$$mv' + kv^2 = 0.$$

tenglama bilan aniqlanadi. ☹

2-misol. Tekislikdagi egri chiziqning ixtiyoriy M nuqtasiga o'tkazilgan urinma, bu nuqtadan Oy o'qqa parallel o'tgan to'g'ri chiziq va koordinata o'qlari bilan chegaralangan $OAMB$ trapetsiyaning yuzi S ga teng. M nuqta harakat qonuni tenglamasini tuzing.

☹ $M(x; y)$ noma'lum (izlanayotgan) egri chiziqning ixtiyoriy nuqtasi bo'lsin.

U holda $OAMB$ trapetsiyaning yuzi $S = \frac{1}{2}(OA + BM) \cdot OB$ tenglik bilan ifodalanadi, bu yerda $OB = AC = x$, $BM = y$,

$$OA = CB = BM - CM = BM - AC \cdot \operatorname{tg}\alpha = y - x \cdot \operatorname{tg}\alpha \quad (1\text{-shakl}).$$

Birinchi tartibli hosilaning geometrik ma'nosiga ko'ra $\operatorname{tg}\alpha = y'$.

U holda $S = \frac{1}{2}(y - xy' + y)x$.

Demak, M nuqtaning harakat qonuni

$$x^2 y' - 2xy + 2S = 0. \quad \text{☹}$$

Differensial tenglamaning berilgan $y|_{x=x_0} = y_0$ (yoki $y(x_0) = y_0$) boshlang'ich shart bo'yicha xususiy yechimini topish masalasi *Koshi masalasi* deyiladi.

Teorema (*Koshi masalasi yechimining mavjudligi va yagonaligi haqidagi teorema*).

Agar $P_0(x_0, y_0)$ nuqtani o'z ichiga olgan

D sohada $f(x, y)$ funksiya va $\frac{\partial f}{\partial y}$ xususiy

hosila uzluksiz bo'lsa, u holda $y' = f(x, y)$

differensial tenglamaning $y|_{x=x_0} = y_0$ shartni qanoatlantiruvchi $y = \varphi(x)$

yechimi mavjud va yagona bo'ladi.

Teoremaning shartlari buziladigan nuqtalar *maxsus nuqtalar* deyiladi.

Maxsus nuqtalar orqali yoki birorta ham integral egri chiziq o'tmaydi yoki bir nechta integral egri chiziq o'tadi.

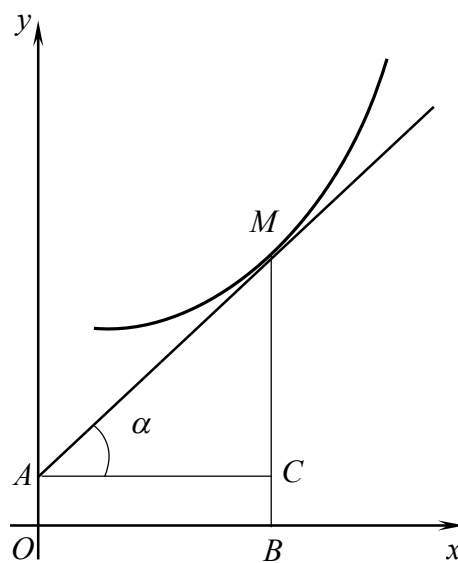

1-shakl.

3.1.2. Umumiy yechimi chekli sondagi elementar almashtirishlar va kvadraturalar (elementar funksiyalarni integrallashlar) natijasida topiladigan birinchi tartibli differensial tenglamaga *kvadraturada integrallanuvchi* differensial tenglama deyiladi.

O'zgaruvchilari ajraladigan differensial tenglamalar

Ushbu

$$M(x)dx + N(y)dy = 0 \quad (1.3)$$

ko'rinishdagi tenglamaga *o'zgaruvchilari ajralgan* differensial tenglama deyiladi.

(1.3) tenglamaning umumiy yechimi uni hadma-had integrallash orqali topiladi

$$\int M(x)dx + \int N(y)dy = C.$$

3-misol. Koshi masalasini yeching:

$$\frac{2xdx}{x^2 - 1} + \frac{dy}{y^2} = 0, \quad y(0) = 1.$$

O'zgaruvchilari ajralgan differensial tenglama berilgan.

Uni hadma-had integrallaymiz:

$$\int \frac{2xdx}{x^2 - 1} + \int \frac{dy}{y^2} = 0.$$

Bundan tenglamaning umumiy yechimini topamiz:

$$\ln|x^2 - 1| - \frac{1}{y} = C \quad \text{yoki} \quad y = \frac{1}{\ln|x^2 - 1| - C}.$$

Koshi masalasini yechish uchun tenglamaning umumiy yechimidan $y(0) = 1$ shartni qanoatlantiruvchi C ni aniqlaymiz:

$$1 = \frac{1}{\ln|-1| - C}, \quad C = -1.$$

Demak, Koshi masalasining yechimi

$$y = \frac{1}{\ln|x^2 - 1| + 1} \quad \text{O}$$

Ushbu

$$M_1(x) \cdot N_1(y)dx + M_2(x) \cdot N_2(y)dy = 0, \quad (1.4)$$

$$y' = f_1(x)f_2(y) \quad (1.5)$$

tenglamalarga *o'zgaruvchilari ajraladigan* differensial tenglamalar deyiladi.

(1.4) tenglama $N_1(y)M_2(x)$ ifodaga hadma-had bo'lish orqali o'zgaruvchilari ajralgan tenglamaga keltiriladi

$$\frac{M_1(x)}{M_2(x)}dx + \frac{N_2(y)}{N_1(y)}dy = 0.$$

⇒ (1.4) tenglamani $N_1(y)M_2(x)$ ifodaga hadma-had bo'lishda ayrim yechimlar tushib qolishi mumkin. Shu sababli bunda $N_1(y)M_2(x) = 0$ tenglamani alohida yechish va bu yechimlar orasidan maxsus yechimlarni ajratish kerak bo'ladi.

4-misol. Koshi masalasini yeching:

$$(1+x^2)dy + (1+y^2)dx = 0, \quad y(0) = 1.$$

⊖ Tenglamani $(1+x^2)(1+y^2) \neq 0$ ga bo'lib, o'zgaruvchilarni ajratamiz:

$$\frac{dx}{1+x^2} + \frac{dy}{1+y^2} = 0.$$

Bu tenglamani integrallaymiz:

$$\arctg x + \arctg y = C.$$

Bundan

$$\begin{aligned} \operatorname{tg}(\arctg x + \arctg y) &= \operatorname{tg} C, \quad \frac{x+y}{1-xy} = C_1, \quad \text{bu yerda } C_1 = \operatorname{tg} C \text{ yoki} \\ y &= \frac{C_1 - x}{1 + C_1 x}. \end{aligned}$$

C_1 o'zgaruvchisining qiymatini boshlang'ich shartdan topamiz: $C_1 = 1$.

Demak, berilgan Koshi masalasining yechimi

$$y = \frac{1-x}{1+x}. \quad \ominus$$

(1.5) tenglama $y' = \frac{dy}{dx}$ o'rniga qo'yish orqali o'zgaruvchilari ajralgan

$$\frac{dy}{f_2(y)} = f_1(x)dx$$

tenglamaga keltiriladi.

⇒ $y' = f(ax + by + c)$ ko'rinishdagi integrallar (bu yerda a, b, c – sonlar) $ax + by + c = u$ almashtirish yordamida o'zgaruvchilari ajraladigan tenglamaga keltiriladi.

5-misol. $y' + 2y = 3x + 5$ tenglamaning umumiy yechimini toping.

⊖ Tenglamani $y' = 3x - 2y + 5$ ko'rinishda yozib olamiz.

$u = 3x - 2y + 5$, $u' = 3 - 2y'$ o'rniga qo'yishlar bajarib, $y' = 3x - 2y + 5$ tenglamani o'zgaruvchilari ajraladigan tenglamaga keltiramiz:

$$3 - u' = 2u \quad \text{yoki} \quad \frac{du}{dx} = 3 - 2u.$$

Bundan

$$\frac{du}{2u - 3} = -dx.$$

Bu tenglamani integrallaymiz:

$$\frac{1}{2} \ln |2u - 3| = -x + \ln C \quad \text{yoki} \quad 2u - 3 = Ce^{-2x}.$$

Teskari o'rniga qo'yish bajarib, berilgan tenglamaning umumiy yechimini topamiz:

$$6x - 4y + 7 = Ce^{-2x}. \quad \odot$$

Bir jinsli differensial tenglamalar

☑ Agar $f(x, y)$ funksiyada x va y o'zgaruvchilar mos ravishda tx va ty ga almashtirilganda (bu yerda t – ixtiyoriy parametr) $f(tx, ty) = f(x, y)$ shart bajarilsa, $f(x, y)$ funksiyaga *bir jinsli funksiya* deyiladi.

☑ Agar $y' = f(x, y)$ differensial tenglamada $f(x, y)$ bir jinsli funksiya bo'lsa, bu tenglamaga *bir jinsli differensial tenglama* deyiladi.

Bir jinsli differensial tenglama almashtirishlar orqali

$$y' = \varphi\left(\frac{y}{x}\right)$$

ko'rinishda yozib olinadi va keyin $\frac{y}{x} = u$ ($u = u(x)$ – noma'lum funksiya) o'rniga qo'yish orqali o'zgaruvchilari ajraladigan tenglamaga keltiriladi.

6 – misol. $y' = \frac{y}{x} \ln \frac{y}{x}$ tenglamaning umumiy yechimini toping.

☞ Tenglama bir jinsli. Shu sababli $y = ux$, $y' = u'x + x$ o'rniga qo'yishni bajaramiz. U holda berilgan tenglama

$$u'x + u = u \ln u \quad \text{yoki} \quad u'x = u(\ln u - 1)$$

ko'rinishga keladi.

O'zgaruvchilarni ajratamiz:

$$\frac{du}{u(\ln u - 1)} = \frac{dx}{x}.$$

Tenglamani integrallaymiz:

$$\int \frac{du}{u(\ln u - 1)} = \int \frac{dx}{x} \quad \text{yoki} \quad \ln |\ln u - 1| = \ln |x| + \ln C.$$

Bundan

$$\ln u - 1 = xC \quad \text{yoki} \quad u = e^{Cx+1}.$$

$u = \frac{y}{x}$ ekanini inobatga olib, topamiz:

$$\frac{y}{x} = e^{Cx+1} \quad \text{yoki} \quad y = xe^{Cx+1}. \quad \odot$$

7-misol. Tekislikdagi egri chiziqning ixtiyoriy M nuqtasiga o'tkazilgan urinmaning ordinatalar o'qida ajratgan kesmasi urinish nuqtasining absissasiga teng. Egri chiziqlar oilasini toping.

\odot $M(x; y)$ noma'lum (izlanayotgan) egri chiziqning ixtiyoriy nuqtasi bo'lsin. Masalaning shartiga ko'ra: $OA = OC = x$.

$\triangle ADM$ va $\triangle MBC$ uchburchaklarning o'xshashligidan (2-shakl):

$$\frac{AD}{DM} = \frac{MC}{CB}.$$

Bunda

$$AD = AO - DO = AO - MC = x - y,$$

$$DM = OC = x, \quad \frac{MC}{CB} = \operatorname{tg}(180^\circ - \alpha) = -\operatorname{tg}\alpha,$$

bu yerda $\operatorname{tg}\alpha = y'$.

U holda

$$\frac{x - y}{x} = -y' \quad \text{yoki} \quad y' = \frac{y - x}{x}.$$

Bir jinsli tenglama hosil bo'ldi.

Uni yechamiz:

$$u'x + u = u - 1, \quad u'x = -1, \quad du = -\frac{dx}{x}, \quad u = C - \ln|x|.$$

$u = \frac{y}{x}$ o'rniga qo'yish bajarib, egri chiziqlar oilasini topamiz:

$$y = Cx - x \ln|x|. \quad \odot$$

\Rightarrow Ushbu

$$\frac{dy}{dx} = \frac{ax + by + c}{a_1x + b_1y + c_1} \quad (1.6)$$

tenglama $c = c_1 = 0$ bo'lganda bir jinsli tenglama bo'ladi.

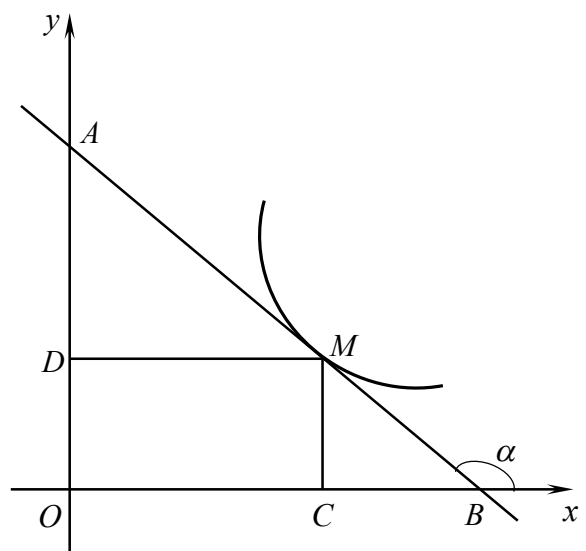

2-shakl.

Agar c va c_1 (yoki ulardan biri) noldan farqli bo'lsa, u holda (1.6) tenglama:

1) $ab_1 - a_1b \neq 0$ bo'lganda $x = x_1 + \alpha$, $y = y_1 + \beta$ almashtirishlar orqali bir jinsli tenglamaga keltiriladi;

2) $ab_1 - a_1b = 0$ bo'lganda $z = ax + by$ o'rniga qo'yish orqali o'zgaruvchilari ajraladigan tenglamaga keltiriladi.

(1.6) tenglamani integrallashda qo'llaniladigan usul

$$\frac{dy}{dx} = f\left(\frac{ax + by + c}{a_1x + b_1y + c_1}\right)$$

(bu yerda f – ixtiyoriy funksiya) tenglamani integrallashda ham qo'llaniladi.

8-misol. $y' = \frac{2x + y - 1}{-x + 2y + 3}$ tenglamaning umumiy yechimini toping.

☉ Shartga ko'ra: $a = 2$, $b = 1$, $a_1 = -1$, $b_1 = 2$, $ab_1 - a_1b = 2 \cdot 2 - (-1) \cdot 1 = 5 \neq 0$.

Bu koeffitsiyentlardan

$$\begin{cases} 2\alpha + \beta - 1 = 0, \\ -\alpha + 2\beta + 3 = 0 \end{cases}$$

sistemani tuzamiz.

Uning yechimi: $\alpha = 1$, $\beta = -1$.

U holda

$$\frac{dy_1}{dx_1} = \frac{2x_1 + y_1}{-x_1 + 2y_1}$$

kelib chiqadi.

Bu tenglamani yechamiz:

$$u'x_1 + u = \frac{2 + u}{2u - 1} \quad \text{yoki} \quad \frac{(2u - 1)du}{2(1 + u - u^2)} = \frac{dx_1}{x_1}.$$

Bu tenglamani integrallaymiz:

$$1 + u - u^2 = \frac{C}{x_1^2}.$$

x_1 va y_1 o'zgaruvchilarga qaytamiz:

$$1 + \frac{y_1}{x_1} - \frac{y_1^2}{x_1^2} = \frac{C}{x_1^2} \quad \text{yoki} \quad x_1^2 + x_1y_1 - y_1^2 = C.$$

$x_1 = x - 1$ va $y_1 = y + 1$ o'rniga qo'yish bajarib, almashtirishlardan keyin topamiz:

$$x^2 + xy - y^2 - x - 3y = \bar{C}, \quad \text{bu yerda } \bar{C} = C + 1. \quad \text{☉}$$

9-misol. $y' = -\frac{2x+3y-1}{4x+6y-5}$ tenglamaning umumiy yechimini toping.

☉ Shartga ko'ra: $a=2$, $b=3$, $a_1=-4$, $b_1=-6$.

Bundan $ab_1 - a_1b = 2 \cdot (-6) - (-4) \cdot 3 = 0$. Shu sababli $2x + 3y - 1 = u$ belgilash kiritamiz. Bundan $2 + 3y' = u'$ yoki $y' = \frac{u' - 2}{3}$.

U holda berilgan tenglama

$$\frac{u' - 2}{3} = -\frac{u}{2u - 3}$$

ko'rinishga keladi. Bundan

$$\frac{2u - 3}{u - 6} du = dx$$

tenglama kelib chiqadi. Uni integrallaymiz:

$$2u + 9 \ln |u - 6| = x + C.$$

x va y o'zgaruvchilarga qaytamiz:

$$x + 2y + 3 \ln |2x + 3y - 7| = \bar{C}, \text{ bu yerda } \bar{C} = \frac{C + 2}{3}. \quad \text{☉}$$

⇒ Bir jinsli bo'lmagan ayrim differensial tenglamalar

$$y = z^n, \quad y' = nz^{n-1}z'$$

o'rniga qo'yishlar orqali bir jinsli tenglamaga keltirilishi mumkin.

10-misol. $2x^2y' = y^3 + xy$ tenglamani bir jinsli tenglama ko'rinishiga keltiring.

☉ Berilgan tenglamada $y = z^n$, $y' = nz^{n-1}z'$ o'rniga qo'yishlarni bajaramiz:

$$2x^2nz^{n-1}z' = z^{3n} + xz^n.$$

Bu tenglama barcha hadlarining daraja ko'rsatkichlari teng bo'lganda bir jinsli bo'ladi: $2 + n - 1 = 3n = n + 1$.

Bu tengliklardan topamiz: $n = \frac{1}{2}$. U holda berilgan tenglama

$$2x^2 \cdot \frac{1}{2} z^{\frac{1}{2}-1} z' = y^{\frac{3}{2}} + xz^{\frac{1}{2}} \quad \text{yoki} \quad \frac{x^2}{\sqrt{z}} z' = z\sqrt{z} + x\sqrt{z}$$

ko'rinishga keladi.

Oxirgi tenglikdan

$$x^2 z' = z^2 + xz \quad \text{yoki} \quad z' = \frac{z^2 + xz}{x^2}$$

bir jinsli tenglama kelib chiqadi. ☉

Chiziqli differensial tenglamalar

☐ Noma'lum funksiya va uning hosilasiga nisbatan chiziqli bo'lgan

$$y' + P(x)y = Q(x) \quad (1.7)$$

tenglamaga *chiziqli bir jinsli bo'lmagan differensial tenglama* deyiladi, bu yerda $P(x), Q(x) \neq 0$ – x ning uzluksiz funksiyalari (yoki o'zgarmlar).

Ushbu

$$y' + P(x)y = 0 \quad (1.8)$$

(1.7) tenglamaga mos *chiziqli bir jinsli* tenglama deyiladi. Chiziqli bir jinsli tenglama o'zgaruvchilari ajraladigan tenglama bo'ladi.

Chiziqli bir jinsli bo'lmagan differensial tenglamaning yechimi x ning ikkita funksiyasi ko'paytmasi $y = u(x) \cdot v(x)$ ko'rinishida izlanadi. Bunda funksiyalardan biri, masalan $v(x)$, tanlab olinadi va ikkinchisi (1.7) tenglmdan aniqlanadi. Chiziqli tenglamani yechishning bu usuliga Bernulli usuli deyiladi.

11-misol. $y' - \frac{y}{x} = \frac{x}{1+x^2}$ tenglamaning umumiy yechimini toping.

☞ Berilgan tenglama chiziqli: $P(x) = -\frac{1}{x}$, $Q(x) = \frac{x}{1+x^2}$.

$y = uv$, $y' = u'v + v'u$ o'rniga qo'yishni bajaramiz:

$$u'v + u\left(v' - \frac{v}{x}\right) = \frac{x}{1+x^2}.$$

Bu tenglamadan

$$\begin{cases} v' - \frac{v}{x} = 0, \\ u'v = \frac{x}{1+x^2} \end{cases}$$

sistema kelib chiqadi. Sistemaning birinchi tenglamasini integrallaymiz:

$$\frac{dv}{v} = \frac{dx}{x}, \quad \int \frac{dv}{v} = \int \frac{dx}{x}, \quad \ln|v| = \ln|x| + \ln C, \quad v = Cx$$

yoki $C=1$ da $v=x$.

v ni sistemaning ikkinchi tenglamasiga qo'yamiz:

$$u'x = \frac{x}{1+x^2} \quad \text{yoki} \quad u' = \frac{1}{1+x^2}.$$

Bundan $u = \arctg x + C$. Demak, tenglamaning umumiy yechimi

$$y = x(C + \arctg x). \quad \text{☐}$$

⇒ Agar differensial tenglama x va uning hosilasiga nisbatan chiziqli bo'lgan

$$x' + P_1(y)x = Q_1(y)$$

ko'rinishga berilgan bo'lsa, u holda $x = u(y) \cdot v(y)$ o'rniga qo'yish bajariladi.

12-misol. $(y^2 - 6x)y' + 2y = 0$ tenglamaning umumiy yechimini toping.

⊖ Berilgan tenglama y erkli o'zgaruvchi va uning x funksiyasi uchun chiziqli tenglama bo'ladi:

$$2y \frac{dx}{dy} - 6x = -y^2 \quad \text{yoki} \quad x' - \frac{3}{y}x = -\frac{y}{2}, \quad P(y) = -\frac{3}{y}, \quad Q(y) = -\frac{y}{2}.$$

$x = uv$, $x' = u'v + v'u$ o'rniga qo'yishni bajaramiz:

$$u'v + u \left(v' - \frac{3v}{y} \right) = -\frac{y}{2}.$$

Bu tenglamadan

$$\begin{cases} v' - \frac{3v}{y} = 0, \\ u'v = -\frac{y}{2} \end{cases}$$

sistema kelib chiqadi.

Sistemaning birinchi tenglamasini integrallaymiz:

$$\frac{dv}{v} = 3 \frac{dy}{y}, \quad \int \frac{dv}{v} = 3 \int \frac{dy}{y}, \quad \ln |v| = 3 \ln |y|, \quad v = Cy^3$$

yoki $C = 1$ da $v = y^3$.

v ni sistemaning ikkinchi tenglamasiga qo'yamiz:

$$u' = -\frac{1}{2y^2}.$$

Bundan

$$u = \frac{1}{2y} + C.$$

Demak, tenglamaning umumiy yechimi

$$x = \frac{1}{2} y^2 (1 + 2Cy). \quad \ominus$$

⇒ Bir jinsli bo'lmagan (1.7) tenglamani yechishda *ixtiyoriy o'zgarmasni variatsiyalash usuli* deb ataluvchi usul qo'llanilishi mumkin.

(1.7) tenglamani ixtiyoriy o'zgarmasni variatsiyalash usuli bilan yechish ikki bosqichda amalga oshiriladi.

Birinchi bosqichda (1.7) tenglamaga mos bir jinsli (1.8) tenglama yechiladi:

$$y = Ce^{-\int P(x)dx}.$$

Ikkinchi bosqichda (1.7) tenglamaning umumiy yechimi $y = Ce^{-\int P(x)dx}$ ko‘rinishda izlanadi. Bunda C o‘zgarmas biror differensiallanuvchi $C(x)$ funk-siyaga tenglashtiriladi, ya‘ni C o‘zgarmas variatsiyalanadi.

⇒ Chiziqli differensial tenglamalarni yechishning ixtiyoriy o‘zgarmasni variatsiyalash usulida yechimning ko‘rinishini yodda saqlash shart emas, balki bu yechimni topish algoritmini bilish muhim: birinchi bosqichda berilgan tenglamaga mos bir jinsli tenglama yechiladi va ikkinchi bosqichda bir jinsli bo‘lmagan tenglamaning yechimi topilgan bir jinsli tenglamaning yechimi ko‘rinishida izlanadi, buhda ixtiyoriy o‘zgarmas o‘zgaruvchi miqdor deb hisoblanadi.

U holda (1.7) tenglamaning umumiy yechimi

$$y = e^{-\int P(x)dx} (\int Q(x)e^{\int P(x)dx} dx + C)$$

ko‘rinishda bo‘ladi.

13-misol. $y' - \frac{2}{x+1}y = (x+1)^3$ tenglamani ixtiyoriy o‘zgarmasni variatsiyalash usuli bilan yeching.

⊖ Berilgan tenglamaga mos bir jinsli tenglamani yechamiz:

$$y' - \frac{2}{x+1}y = 0, \quad \frac{dy}{y} = \frac{2}{x+1}, \quad \ln y = 2 \ln |x+1| + \ln C, \quad y = C(x+1)^2.$$

Berilgan tenglamaning yechimini

$$y = C(x)(x+1)^2$$

ko‘rinishda izlaymiz.

Bundan

$$y' = C'(x)(x+1)^2 + 2C(x)(x+1).$$

y va y' ni berilgan tenglamaga qo‘yamiz:

$$C'(x)(x+1)^2 + 2C(x)(x+1) - 2C(x)(x+1) = (x+1)^3.$$

U holda

$$C'(x) = (x+1), \quad C(x) = \frac{(x+1)^2}{2} + \bar{C}.$$

Demak, berilgan tenglamaning umumiy yechimi:

$$y = (x+1)^2 \left(\frac{(x+1)^2}{2} + \bar{C} \right). \quad \ominus$$

14-misol. O'zgaras elektr toki zanjirida qisqa tutashuv vaqtida tok kuchining o'zgarish qonunini toping.

☉ Agar R – zanjirning qarshiligi, E – tashqi elektr yurituvchi kuch (EYK) bo'lsa, u holda $I = I(t)$ tok kuchi noldan $\frac{E}{R}$ qiymatgacha o'sib boradi.

L – zanjirning induksiya koeffitsiyenti bo'lsin. U holda tok kuchining har qanday o'zgarishida zanjirda qiymati $L \frac{dI}{dt}$ ga teng va tashqi EYKga qarama-qarshi yo'nalgan EYK hosil bo'ladi. Om qonuniga ko'ra har bir t vaqtda tok kuchining qarshilikka ko'paytmasi qarama-qarshi yo'nalgan tashqi va ichki EYKlar yig'indisiga teng bo'ladi:

$$IR = E - L \frac{dI}{dt} \quad \text{yoki} \quad \frac{dI}{dt} + \frac{R}{L} I = \frac{E}{L} \quad (E, L, R = \text{const}).$$

Oxirgi tenglama bir jinsli bo'lmagan chiziqli differensial tenglama. Bu tenglamaga mos bir jinsli tenglamani yechamiz:

$$\frac{dI}{dt} + \frac{R}{L} I = 0, \quad \frac{dI}{I} = -\frac{R}{L} dt, \quad \ln I = -\frac{R}{L} t + \ln C, \quad I = Ce^{-\frac{R}{L} t}.$$

Tenglamaning yechimini $I = C(x)e^{-\frac{R}{L} t}$ ko'rinishda izlaymiz.

Bundan

$$I' = C(x)e^{-\frac{R}{L} t} - C(x) \frac{R}{L} e^{-\frac{R}{L} t}.$$

I va I' ni berilgan tenglamaga qo'yamiz:

$$C'(x)e^{-\frac{R}{L} t} - C(x) \frac{R}{L} e^{-\frac{R}{L} t} + \frac{R}{L} C(x)e^{-\frac{R}{L} t} = \frac{E}{L}.$$

U holda

$$C'(x) = \frac{E}{L} e^{\frac{R}{L} t}, \quad C(x) = \frac{E}{R} e^{\frac{R}{L} t} + \bar{C}.$$

Demak, berilgan tenglamaning umumiy yechimi:

$$I = \frac{E}{R} + \bar{C} e^{-\frac{R}{L} t}.$$

$t = 0$ da $I(t) = 0$. Shu sababli $\bar{C} = -\frac{E}{R}$.

Demak, izlanayotgan qonun

$$I = \frac{E}{R} \left(1 - e^{-\frac{R}{L} t} \right)$$

tenglama bilan ifodalanadi. ☉

Bernulli tenglamasi

Ushbu

$$y' + P(x)y = Q(x)y^n, \quad n \geq 2 \quad (1.9)$$

ko‘rinishdagi tenglamaga *Bernulli tenglamasi* deyiladi.

Bu tenglama $z = y^{1-n}$, $z' = (1-n)y^{-n}y'$ o‘rniga qo‘yishlar orqali chiziqli tenglamaga keltiriladi:

$$z' + (1-n)Pz = (1-n)Q.$$

Izoh. 1. Bernulli tenglamasidan $n=0$ bo‘lganda chiziqli tenglama, $n=1$ bo‘lganda o‘zgaruvchilari ajraladigan tenglama kelib chiqadi.

2. Bernulli tenglamasini bevosita $y = u \cdot v$ o‘rniga qo‘yish orqali yoki ixtiyoriy o‘zgarmasni variatsiyalash usuli bilan yechish mumkin.

15-misol. $y' + xy = xy^3$ tenglamaning umumiy yechimini toping.

☉ Bernulli tenglamasi berilgan: $n=3$.

$z = y^{1-3} = y^{-2}$ belgilash kiritamiz va berilgan tenglamani

$$z' - 2xz = -2x$$

ko‘rinishga keltiramiz.

$z = uv$, $z' = u'v + v'u$ o‘rniga qo‘yish bajaramiz:

$$u'v + u(v' - 2xv) = -2x.$$

Bu tenglamadan

$$\begin{cases} v' - 2xv = 0, \\ u'v = -2x. \end{cases}$$

sistema kelib chiqadi.

Birinchi tenglamani integrallab $v = e^{x^2}$ xususiy yechimga ega bo‘lamiz va uni ikkinchi tenglamaga qo‘yamiz:

$$u'e^{x^2} = -2x \quad \text{yoki} \quad du = -2xe^{-x^2}.$$

Bundan

$$u = e^{-x^2} + C.$$

U holda

$$z = e^{x^2}(C + e^{-x^2}) \quad \text{yoki} \quad z = 1 + Ce^{x^2}.$$

Demak, berilgan Bernulli tenglamasining umumiy yechimi:

$$y^{-2} = 1 + Ce^{x^2} \quad \text{yoki} \quad y^2(1 + Ce^{x^2}) = 1. \quad \text{☉}$$

To'liq differensialli tenglamalar

Agar

$$M(x, y)dx + N(x, y)dy = 0 \quad (1.10)$$

tenglamaning chap qismi biror $u(x, y)$ funksiyaning to'liq differensial, ya'ni

$$du = M(x, y)dx + N(x, y)dy$$

bo'lsa, (1.10) tenglamaga *to'liq differensialli tenglama* deyiladi.

Agar $\frac{\partial M}{\partial y} = \frac{\partial N}{\partial x}$ shart bajarilsa (1.10) to'liq differensialli tenglama

bo'ladi. Bunda (1.10) tenglamaning umumiy yechimi

$$\int M(x, y)dx + \int \left(N(x, y) - \int \frac{\partial M}{\partial y} dx \right) dy = C \quad (1.11)$$

formula bilan aniqlanadi.

16-misol. $(y + e^x \sin y)dx + (x + e^x \cos y)dy = 0$ tenglamaning umumiy yechimini toping.

☞ Tenglamada $M(x, y) = y + e^x \sin y$, $N(x, y) = x + e^x \cos y$.

Bunda $\frac{\partial M}{\partial y} = 1 + e^x \cos y$, $\frac{\partial N}{\partial x} = 1 + e^x \cos y$, ya'ni $\frac{\partial M}{\partial y} = \frac{\partial N}{\partial x}$.

Demak, tenglama to'liq differensialli.

$\frac{\partial u}{\partial x} = M(x, y)$ bo'lgani uchun $\frac{\partial u}{\partial x} = y + e^x \sin y$. Bu tenglikni x bo'yicha integrallaymiz :

$$u = yx + e^x \sin y + \varphi(y).$$

Bundan

$$\varphi(y) = u - yx - e^x \sin y \text{ va } \varphi'(y) = \frac{\partial u}{\partial y} - x - e^x \cos y.$$

Bunda $\frac{\partial u}{\partial y} = N(x, y)$ ekani inobatga olinsa $\varphi'(y) = 0$ bo'ladi. U holda $\varphi(y) = \bar{C}$.

Demak,

$$u = e^x \sin y + yx + \bar{C} \text{ yoki } yx + e^x \sin y = C. \quad \ominus$$

☞ $\frac{\partial M}{\partial y} = \frac{\partial N}{\partial x}$ shart bajarilmasa (1.10) tenglama to'liq differensialli

bo'lmaydi. Bunday tenglamani *integrallovchi ko'paytuvchi* deb ataluvchi $\mu(x, y)$ funksiyaga ko'paytirish orqali to'liq differensialli tenglamaga keltirish mumkin.

$\mu(x, y)$ integrallovchi ko‘paytuvchi

$$\frac{\partial \mu}{\partial y} \cdot M - \frac{\partial \mu}{\partial x} \cdot N = \mu \cdot \left(\frac{\partial N}{\partial x} - \frac{\partial M}{\partial y} \right)$$

xususiyl hosilali differensial tenglama yechimidan iborat bo‘ladi.

Integrallovchi ko‘paytuvchini quyidagi hollarda oson topiladi:

1) $\frac{\frac{\partial M}{\partial y} - \frac{\partial N}{\partial x}}{N} = F(x)$ bo‘lganda u $\mu(x) = e^{\int F(x) dx}$ kabi aniqlanadi;

2) $\frac{\frac{\partial N}{\partial x} - \frac{\partial M}{\partial y}}{M} = \Phi(y)$ bo‘lganda u $\mu(y) = e^{\int \Phi(y) dy}$ kabi aniqlanadi.

17-misol. $(x^2 - y)dx + xdy = 0$ tenglamaning umumiy yechimini toping.

☉ Tenglamada $M(x, y) = x^2 - y$, $N(x, y) = x$.

Bundan $\frac{\partial M}{\partial y} = -1$, $\frac{\partial N}{\partial x} = 1$, ya’ni $\frac{\partial M}{\partial y} \neq \frac{\partial N}{\partial x}$.

Demak, tenglama to‘liq differensialli emas.

Berilgan tenglama uchun integrallovchi ko‘paytuvchini topamiz:

$$F(x) = \frac{\frac{\partial M}{\partial y} - \frac{\partial N}{\partial x}}{N} = \frac{-1 - 1}{x} = -\frac{2}{x},$$

$$\mu(x) = e^{\int F(x) dx} = e^{-2 \int \frac{dx}{x}} = e^{-2 \ln x} = \frac{1}{x^2}.$$

Berilgan tenglamani $\mu(x)$ ga ko‘paytiramiz:

$$\left(1 - \frac{y}{x^2} \right) dx + \frac{1}{x} dy = 0.$$

Bu tenglamada

$$\frac{\partial M}{\partial y} = \frac{\partial N}{\partial x} = -\frac{1}{x^2}.$$

Tenglamaning yechimini (1.11) formula bilan topamiz:

$$\int \left(1 - \frac{y}{x^2} \right) dx + \int \left(\frac{1}{x} - \int \left(-\frac{1}{x^2} \right) dx \right) dy = C, \quad x + \frac{y}{x} + \int \left(\frac{1}{x} - \frac{1}{x} \right) dy = C.$$

Demak,

$$x + \frac{y}{x} = C. \quad \text{☉}$$

3.1.3. Ushbu

$$F(x, y, y') = 0 \quad (1.12)$$

ko‘rinishdagi tenglamaga *hosilaga nisbatan yechilmagan differensial tenglama* deyiladi.

(1.12) tenglamani integrallashning ayrim usullarini keltiramiz.

1°. (1.12) tenglama

$$F(y') = 0 \quad (1.13)$$

ko‘rinishda berilgan bo‘lib, bunda tenglamaning hech bo‘lmaganda bitta $y' = k_i$ yechimi mavjud bo‘lsin.

U holda

$$F\left(\frac{y-C}{x}\right) = 0$$

bo‘ladi.

18-misol. $y'^5 - 2y'^4 + 3y' - 6 = 0$ tenglamani yeching.

☞ $y' = k$ berilgan tenglamaning yechimi bo‘lsin. U holda $dy = kdx$ dan $y = kx + C$ bo‘ladi. Bundan

$$y' = k = \frac{y-C}{x}.$$

Demak, berilgan tenglamaning yechimi

$$\left(\frac{y-C}{x}\right)^5 - 2\left(\frac{y-C}{x}\right)^4 + 3\left(\frac{y-C}{x}\right) - 6 = 0. \quad \text{☞}$$

2°. (1.12) tenglama

$$F(y, y') = 0 \quad (1.14)$$

ko‘rinishda bo‘lsin. Bu tenglamani y' ga nisbatan yechish oson bo‘lmaganda t parametr kiritiladi va (1.14) tenglama ikkita parametrik tenglama bilan almashtiriladi:

$$y = \varphi(t), \quad y' = \psi(t), \quad t_0 \leq t \leq t_1, \quad \text{bu yerda } F(\varphi(t), \psi(t)) = 0, \quad t \in (t_0; t_1).$$

Bunda (1.14) tenglamaning yechimi

$$x = \int \frac{\varphi'(t)}{\psi(t)} dt + C, \quad y = \varphi(t)$$

parametrik tenglamalar bilan aniqlanadi.

19-misol. $y^{\frac{2}{3}} + y'^{\frac{2}{3}} = 1$ tenglamaning umumiy yechimini toping.

☞ $y = \cos^3 t, \quad y' = \sin^3 t$ bo‘lsin.

U holda

$$dx = \frac{dy}{y} = -\frac{3\cos^2 t \sin t}{\sin^3 t} dt = -3\frac{\cos^2 t}{\sin^2 t} dt.$$

Bundan

$$x = -3\int \frac{\cos^2 t}{\sin^2 t} dt = 3t + 3ctgt + C.$$

Demak, berilgan tenglamaning yechimi

$$x = 3t + 3ctgt + C, \quad y = \cos^3 t$$

parametrik tenglamalar bilan aniqlanadi. \odot

(1.14) tenglamani y ga nisbatan yechish oson bo'lganda parametr $p = y'$ parametr kiritiladi.

Bunda (1.14) tenglamaning yechimi

$$x = \int \frac{\varphi'(p)}{p} dp + C, \quad y = \varphi(p)$$

parametrik tenglamalar bilan aniqlanadi. Bu tengliklardan p parametr yo'qotilsa, $\Phi(x, y, C) = 0$ yechim kelib chiqadi.

20-misol. $y = y'^2 + 4y'^3$ tenglamaning umumiy yechimini toping.

\odot $y' = p$ bo'lsin. U holda tenglama

$$y = p^2 + 4p^3.$$

ko'rinishga keladi. Bundan

$$y' = (2p + 12p^2)p', \quad p = (2p + 12p^2)p', \quad p \cdot (1 - 2(1 + 6p)p) = 0.$$

U holda

$$1 - 2(1 + 6p)p' = 0, \quad 1 = 2(1 + 6p)p', \quad dx = 2(1 + 6p)dp, \quad x = 2p + 6p^2 + C.$$

Demak, berilgan tenglamaning yechimi

$$x = 2p + 6p^2 + C, \quad y = p^2 + 4p^3$$

parametrik tenglamalar bilan aniqlanadi.

Bundan tashqari tenglama

$$\begin{cases} y = p^2 + 4p^3, \\ p = 0 \end{cases} \text{ yoki } y = 0$$

maxsus yechimga ega. \odot

3°. (1.12) tenglama

$$F(x, y') = 0 \tag{1.15}$$

ko'rinishda bo'lsin. Bu tenglamani y' ga nisbatan yechish oson bo'lmaganda

t parametr kiritiladi:

$$x = \varphi(t), \quad y' = \psi(t), \quad t_0 \leq t \leq t_1, \quad \text{bu yerda } F(\varphi(t), \psi(t)) = 0, \quad t \in (t_0; t_1).$$

Bunda (1.15) tenglamaning yechimi

$$y = \int \psi(t) \varphi'(t) dt + C, \quad x = \varphi(t)$$

parametrik tenglamalar bilan aniqlanadi.

(1.15) ni y ga nisbatan yechish oson bo'ganda $p = y'$ parametr kiritiladi va quyidagi yechimlar topiladi:

$$y = \int p \varphi'(p) dp + C, \quad x = \varphi(p).$$

Bu tengliklardan p parametrni yo'qatilsa, $\Phi(x, y, C) = 0$ yechim kelib chiqadi.

21-misol. $x = y' \cos y'$ tenglamaning umumiy yechimini toping.

☉ Berilgan tenglamani

$$y' = p, \quad x = p \cos p$$

ko'rinishda yozamiz.

Bu tengliklardan

$$dx = \frac{dy}{p}, \quad dx = (\cos p - p \sin p) dp$$

yoki

$$dy = p(\cos p - p \sin p) dp$$

tenglik kelib chiqadi.

Uni integrallaymiz:

$$y = p^2 \cos p - p \sin p - \cos p + C.$$

Demak, berilgan tenglamaning yechimi

$$x = p \cos p, \quad y = p^2 \cos p - p \sin p - \cos p + C$$

parametrik tenglamalar bilan aniqlanadi. ☉

4°. (1.12) tenglama

$$y = x\varphi(y') + \psi(y') \quad (1.16)$$

ko'rinishda bo'lsin, bu yerda $\varphi(y')$, $\psi(y')$ – y' ning ma'lum funksiyalari.

(1.16) tenglamaga *Lagranj tenglamasi* deyiladi. Lagranj tenglamasi y' ga nisbatan yechilgan bo'lgani sababli $p = y'$ parametr kiritiladi va u

$$y = x\varphi(p) + \psi(p)$$

ko'rinishga keltiriladi. Bu tenglama x bo'yicha differensiallanadi va $x = x(p)$ noma'lumga nisbatan chiziqli

$$(p - \varphi(p)) \frac{dx}{dp} = x\varphi'(p) + \psi'(p)$$

tenglama keltirib chiqariladi. Bu tenglamaning $x = \omega(p, C)$ yechimi va $y = x\varphi(p) + \psi(p)$ tenglamadan p parametrni yo‘qotib, (1.16) tenglamaning umumiy integralini topiladi:

$$y = \gamma(x, C).$$

$y = x\varphi(p) + \psi(p)$ tenglamaga o‘tishda $\frac{dp}{dx}$ bo‘lish bajariladi. Bunda $\frac{dp}{dx} = 0$, ya’ni $p = p_0 = \text{const}$ yechim tushib qolishi mumkin. Parametrning bu qiymati $p - \varphi(p) = 0$ tenglamaning yechimi bo‘ladi. Shu sababli $y = x\varphi(p_0) + \psi(p_0)$ yechim Lagranj tenglamasining maxsus yechimi bo‘ladi.

22-misol. $y = x(1 + y') + y'^2$ tenglamaning umumiy yechimini toping.

☞ Berilgan tenglama Lagranj tenglamasi. Bu tenglamani $y' = p$ deb,

$$y = x(1 + p) + p^2$$

ko‘rinishda yozamiz va differensiallaymiz:

$$y' = (1 + p) + (x + 2p)p'.$$

Bundan

$p = (1 + p) + (x + 2p)p'$, $1 + (x + 2p)p' = 0$, $x' + x + 2p = 0$, $x' + x = -2p$ chiziqli tenglama kelib chiqadi.

Bu tenglamaning yechimi

$$x = 2 - 2p + Ce^{-p}$$

bo‘ladi.

Demak, berilgan tenglamaning yechimi

$$x = 2 - 2p + Ce^{-p}, \quad y = (2 - 2p + Ce^{-p}) \cdot (1 + p) + p^2. \quad \text{☞}$$

5°. (1.19) tenglama

$$y = xy' + \psi(y') \quad (1.17)$$

ko‘rinishda bo‘lsin, bu yerda $\psi(y')$ – y' ning ma’lum funksiyasi.

(1.16) tenglamaga *Klero tenglamasi* deyiladi.

Klero tenglamasi yechishda $p = y'$ parametr kiritiladi.

Bunda (1.17) tenglamaning

$$y = xC + \psi(C)$$

ko‘rinishdagi umumiy yechimi kelib chiqadi.

$x + \psi'(p) = 0$ bo‘lganda (1.16) tenglamaning xususiy yechimi

$$x = -\psi'(p), \quad y = xp + \psi(p)$$

parametrik tenglamalar bilan aniqlanadi. Bu yechim Klero tenglamasining maxsus yechimi bo‘ladi.

23-misol. $y = xy' + \cos y'$ tenglamaning umumiy yechimini toping.

☉ Berilgan tenglama Klero tenglamasi. Bu tenglamani $y' = p$ deb,

$$y = xp + \cos p$$

ko'rinishda yozamiz va differensiallaymiz:

$$p = p + (x - \sin p)p'.$$

Bundan

$$(x - \sin p)p' = 0$$

tenglik kelib chiqadi. Bu tenglikdan $p' = 0$ yoki $p = C$ kelib chiqadi.

U holda berilgan tenglama

$$y = xC + \cos C$$

yechimga ega bo'ladi.

$x - \sin p = 0$ yoki $x = \sin p$ da tenglama maxsus yechimga ega bo'ladi.

Bundan $p = \arcsin x$ yoki $y' = \arcsin x$ kelib chiqadi. Bu tenglamani integrallab berilgan tenglamaning maxsus yechimini topamiz:

$$y = x \arcsin x + \sqrt{1 - x^2} + C \quad \text{☉}$$

Mashqlar

3.1.1. Massasi m ga teng o'q qarshilik kuchi o'q tezligining kvadratiga proporsional bo'lgan devorni teshib o'tmoqda. O'q harakat qonunining tenglamasini tuzing.

3.1.2. Dvigateli o'chirilgandan keyin qayiq harakatini suvning qayiq tezligiga proporsional qarshilik kuchi ta'sirida sekinlatmoqda. Qayiq harakat qonunining tenglamasini tuzing.

3.1.3. Agar havoning qarshiligi sportchi tezligining kvadratiga proporsional bo'lsa, sportchining parashutda tushishi qonini tenglamasini tuzing (havo zichligining o'zgarishi hisobga olinmaydi).

3.1.4. Massasi m ga teng material nuqta t vaqtga to'g'ri proporsional va v harakat tezligiga teskari proporsional kuch ta'sirida to'g'ri chiziqli harakat qilmoqda. Material nuqta harakat qonunining tenglamasini tuzing.

3.1.5. Tekislikdagi egri chiziqning ixtiyoriy M nuqtasiga o'tkazilgan urinmaning urinish nuqtasi va absissalar o'qi orasidagi kesmasi ordinatalar o'qi bilan kesishish nuqtasida teng ikkiga bo'linadi. M nuqta harakat qonuni tenglamasini tuzing.

3.1.6. Tekislikdagi egri chiziqning ixtiyoriy M nuqtasiga o'tkazilgan urinma, urinish nuqtasining radius vektori va absissalar o'qi hosil qilgan uchburchakning yuzi s ga teng. M nuqta harakat qonuni tenglamasini tuzing.

3.1.7. Berilgan funksiya mos differensial tenglamaning yechimi ekanini ko'rsating:

1) $y = -\frac{2}{x^2}$, $xy^2 dx - dy = 0$;

2) $y = \arctg(x + y) + C$, $(x + y)^2 dy - dx = 0$;

3) $y - x = 4e^y$, $(x - y + 1)dy - dx = 0$;

4) $x = te^t$, $y = e^{-t}$, $(1 + xy)dy + y^2 dx = 0$.

3.1.8. O'zgaruvchilari ajraladigan differensial tenglamalarni yeching:

1) $x dx + y dy = 0$;

2) $2x dx - (3y^2 + 1)dy = 0$;

3) $\frac{x dx}{x+1} + \frac{dy}{y} = 0$;

4) $\frac{dx}{x} + \frac{tgy dy}{\ln \cos y} = 0$;

5) $ctg x dx + \frac{dy}{y} = 0$, $y\left(\frac{\pi}{2}\right) = 1$;

6) $\frac{\sin x dx}{\cos^3 x} + \frac{\cos y dy}{\sin^3 y} = 0$, $y\left(\frac{\pi}{4}\right) = \frac{\pi}{4}$;

7) $y' = e^{x+y}$;

8) $x^2 x' + y^2 = 1$;

9) $y' = tg x \cdot tgy$;

10) $y' + \sin \frac{x+y}{2} = \sin \frac{x-y}{2}$;

11) $\sqrt{1-y^2} dx + y\sqrt{1-x^2} dy = 0$;

12) $(1+y^2)x dx - (1+x^2)y dy = 0$;

13) $y' \sin x - y \ln y = 0$, $y\left(\frac{\pi}{2}\right) = e$;

14) $y' = (2y+1)ctg x$, $y\left(\frac{\pi}{4}\right) = \frac{1}{2}$;

15) $(1+x)y dx + (1-y)x dy = 0$, $y(1) = 1$;

16) $ye^{2x} dx - (1+e^{2x})dy = 0$, $y(0) = \sqrt{2}$;

17) $y' + y = x + 1$;

18) $(x+2y)y' = 1$;

19) $y' = \sqrt{4x-2y-1}$;

20) $y' = \sin(y-x)$.

3.1.9. Bir jinsli differensial tenglamalarni yeching:

1) $(x+2y)dx - xdy = 0$;

2) $(x+y)dx + (x-y)dy = 0$;

3) $y(x+y)dx - x(2x+y)dy = 0$;

4) $(y - \sqrt{x^2 + y^2})dx - xdy = 0$;

5) $xydx + (y^2 - x^2)dy = 0$;

6) $(x^2 + xy + y^2)dx - x^2 dy = 0$;

7) $x\left(y' + e^{\frac{y}{x}}\right) = y;$

8) $xy' = y + x \operatorname{tg} \frac{y}{x};$

9) $ydx + (\sqrt{xy} - x)dy = 0, \quad y(1) = 1;$

10) $2xydx + (y^2 - 3x^2)dy = 0, \quad y(0) = 1;$

11) $(2x + y + 1)dx + (x + 2y - 1)dy = 0;$

12) $(y + 2)dx - (2x + y - 4)dy = 0;$

13) $(x + y + 2)dx + (2x + 2y - 1)dy = 0;$

14) $(2x + y + 1)dx - (4x + 2y - 3)dy = 0.$

3.1.10. Tenglamalarni bir jinsli tenglama ko‘rinishiga keltiring:

1) $(x^2y^2 - 1)y' + 2xy^3 = 0;$

2) $2y' + x = 4\sqrt{y}.$

3.1.11. Parallel tarqatilgan nurlarni jamlovchi oyna tenglamasini tuzing (oyna Oxy tekislikda qaralsin, nurlar Ox o‘qqa parallel tarqatilsin, nurlar O nuqtaga jamlansin).

3.1.12. Tekislikdagi $A(0;1)$ nuqtadan o‘tuvchi egri chiziqning ixtiyoriy M nuqtasiga o‘tkazilgan urinmaning Ox o‘qdagi proeksiyasi urinish nuqtasi koordinatalarining o‘rta arifmetigiga teng. Egri chiziq tenglamasini tuzing.

3.1.13. Chizikli differensial tenglamalarni yeching:

1) $(2x + 1)y' = 4x + 2y;$

2) $y' - y \operatorname{tg} x = c \operatorname{tg} x;$

3) $ydx - (x + y^2)dy = 0;$

4) $y^2dx - (2xy + 3)dy = 0.$

3.1.14. Chizikli differensial tenglamalarni ixtiyoriy o‘zgarmasni variatsiyalash usuli bilan yeching:

1) $xy' - 2y = 2x^4;$

2) $y' + \frac{y}{x} = 2 \ln x + 1;$

3) $xy' + y - e^x = 0, \quad y(2) = 3;$

4) $y' + y \operatorname{tg} x = \frac{1}{\cos x}, \quad y(0) = 0.$

3.1.15. Tekislikdagi $O(0;0)$ nuqtadan o‘tuvchi egri chiziq ixtiyoriy nuqtasining burchak koeffitsiyenti bu nuqta koordinatalarining yig‘indisiga teng. Egri chiziq tenglamasini tuzing.

3.1.16. m massali material nuqta nolga teng boshlang‘ich tezlik bilan suvga tushirilmoqda. Nuqtaga o‘g‘irlik kuchi va tushish tezligiga proporsional suvning qarshilik kuchi ta’sir qilmoqda (k – proporsionallik koeffitsiyenti). Nuqta harakat tezligi tenglamasini tuzing.

3.1.17. Bernulli tenglamalarini yeching:

- 1) $y' + \frac{y}{x+1} + y^2 = 0;$
- 2) $y' + \frac{y}{x} = x^2 y^4;$
- 3) $y' - \frac{y}{2x} = -\frac{1}{2y};$
- 4) $xy' + y = y^2 \ln x;$
- 5) $y' - y \operatorname{tg} x = -y^2 \cos x;$
- 6) $y' + \frac{3x^2 y}{1+x^3} = y^2(1+x^3) \sin x, \quad y(0) = 1.$

3.1.18. To'liq differensialli tenglamalarni yeching:

- 1) $(x+y)dx + (x-2y)dy = 0;$
- 2) $\frac{y}{x}dx + (y^3 + \ln x)dy = 0;$
- 3) $(3x^2 + 2y)dx + (2x-3)dy = 0;$
- 4) $e^{-y}dx - (2y + xe^{-y})dy = 0;$
- 5) $(2x + \ln y)dx + \left(\frac{x}{y} + \sin y\right)dy = 0;$
- 6) $(2x^3 - xy^2)dx + (2y^3 - x^2y)dy = 0.$

3.1.19. Tenglamalarni integrallovchi ko'paytuvchi yordamida to'liq differensialli tenglamaga keltiring va yeching:

- 1) $(x^2 + y)dx - xdy = 0;$
- 2) $(xy^2 + y)dx - xdy = 0;$
- 3) $(e^x + \sin x)dx + \cos x dy = 0;$
- 4) $(x^2 - \sin^2 y)dx + x \sin 2y dy = 0.$

3.1.20. Differensial tenglamalarni yeching:

- 1) $y = y'^2 e^{y'};$
- 2) $y\sqrt{y'-1} = 2 - y';$
- 3) $y = y'\sqrt{1+y'^2};$
- 4) $y = (y'-1)e^{y'};$
- 5) $x = y'^3 - y' + 2;$
- 6) $x = 2y' - \ln y';$
- 7) $x = 2 \ln y' - y';$
- 8) $x = y'^2 - y' - 1;$
- 9) $x = \frac{1}{2}y'^2 + y' - \frac{1}{2}x^2;$
- 10) $y = (x+1)y'^2.$

3.1.21. Lagranj va Klero tenglamalarini yeching:

- 1) $y = x(y'-1) + y'^2;$
- 2) $y = xy'^2 + y'^3;$
- 3) $y = xy'^2 + y'^2;$
- 4) $y = xy'^2 + y';$
- 5) $y = xy' - y'^4;$
- 6) $y = xy' + y' + \sqrt{y'};$
- 7) $y = xy' + \frac{1}{y'^2};$
- 8) $y = xy' + \frac{1}{y'}.$

3.2. YUQORI TARTIBLI DIFFERENSIAL TENGLAMALAR

Tartibini pasaytirish mumkin bo'lgan differensial tenglamalar

3.2.1. Tartibi birdan yuqori bo'lgan differensial tenglamaga yuqori tartibli differensial tenglama deyiladi. n – tartibli oddiy differensial tenglama umumiy holda

$$F(x, y, y', y'', \dots, y^{(n)}) = 0, \quad n \geq 2,$$

ko'rinishda yoziladi, bu yerda x – erkli o'zgaruvchi, y – noma'lum funksiya, $y', y'', \dots, y^{(n)}$ – noma'lum funksiyaning hosilalari, F – $(n+1)$ o'lchamli R^{n+1} sohada $(n+1)$ o'zgaruvchining funksiyasi.

$y^{(n)}$ ga nisbatan yechilgan n – tartibli differensial tenglama

$$y^{(n)} = f(x, y, y', y'', \dots, y^{(n-1)})$$

ko'rinishda ifodalanadi, bu yerda f – berilgan funksiya.

n – tartibli differensial tenglamaning *umumiy yechimi* deb, n ta ixtiyoriy o'zgarmasga bog'liq bo'lgan quyidagi shartlarni qanoatlantiruvchi $y = \varphi(x, C_1, C_2, \dots, C_n)$ funksiyaga aytiladi:

a) y C_1, C_2, \dots, C_n ixtiyoriy o'zgarmaslarning istalgan qiymatida (2.2) differensial tenglamani qanoatlantiradi;

b) boshlang'ich $y|_{x=x_0} = y_0, y'|_{x=x_0} = y'_0, y''|_{x=x_0} = y''_0, \dots, y^{(n-1)}|_{x=x_0} = y^{(n-1)}_0$ shartlar har qanday bo'lganda ham, ixtiyoriy o'zgarmaslarning shunday $\bar{C}_1, \bar{C}_2, \dots, \bar{C}_n$ qiymatlarini topish mumkinki, $y = \varphi(x, \bar{C}_1, \bar{C}_2, \dots, \bar{C}_n)$ yechim boshlang'ich shartlarni qanoatlantiradi, ya'ni

$$\begin{cases} y_0 = \varphi(x_0, \bar{C}_1, \bar{C}_2, \dots, \bar{C}_n), \\ y'_0 = \varphi'(x_0, \bar{C}_1, \bar{C}_2, \dots, \bar{C}_n), \\ \dots \dots \dots \dots \dots \\ y_0^{(n-1)} = \varphi_0^{(n-1)}(x, \bar{C}_1, \bar{C}_2, \dots, \bar{C}_n) \end{cases}$$

bo'ladi.

⇒ Differensial tenglamaning $y|_{x=x_0} = y_0, y'|_{x=x_0} = y'_0, y''|_{x=x_0} = y''_0, \dots, y^{(n-1)}|_{x=x_0} = y^{(n-1)}_0$ boshlang'ich shart bo'yicha xususiy yechimini topish masalasi *Koshi masalasi* deyiladi.

Teorema. Agar $(x_0; y_0; y'_0; y''_0; \dots; y_0^{(n-1)})$ nuqtani o'z ichiga olgan D sohada

$f(x, y, y', y'', \dots, y^{(n-1)})$ funksiya $\frac{\partial f}{\partial y}, \frac{\partial f}{\partial y'}, \frac{\partial f}{\partial y''}, \dots, \frac{\partial f}{\partial y^{(n-1)}}$ xususiy hosilalari bilan uzluksiz bo'lsa, u holda $y^{(n)} = f(x, y, y', y'', \dots, y^{(n-1)})$ differensial tenglamaning $y|_{x=x_0} = y_0, y'|_{x=x_0} = y'_0, y''|_{x=x_0} = y''_0, \dots, y^{(n-1)}|_{x=x_0} = y_0^{(n-1)}$ shartlarni qanoatlantiruvchi yechimi mavjud va yagona bo'ladi.

1-misol. $y'' = \frac{y\sqrt{y'}}{x}$ differensial tenglama yechimining mavjudlik va yagonalik sohasini toping.

☞ $f(x, y, y') = \frac{y\sqrt{y'}}{x}$ funksiya va uning $\frac{\partial f}{\partial y} = \frac{\sqrt{y'}}{x}$ xususiy hosilasi $x \neq 0, y' \geq 0$ da uzluksiz. $\frac{\partial f}{\partial y'} = \frac{y}{2x\sqrt{y'}}$ xususiy hosila $x \neq 0, y' > 0$ da uzluksiz.

Demak, berilgan tenglama $x \neq 0, y' > 0$ da yagona yechimga ega bo'ladi. ☞

⇒ Ayrim hollarda n -tartibli differensial tenglamaning shunday yechimini topish zaruriyati tug'iladiki, bunda yechim qaralayotgan kesmaning chetki nuqtalarida berilgan qiymatlarni qabul qiladi. Bunday shartlar *chegaraviy shartlar* deyiladi. Tenglamaning chegaraviy shartlarini qanoatlantiruvchi yechimni topish masalasi *chegaraviy masala* deyiladi.

Yuqori tartibli differensial tenglamalarni yechish usullaridan biri *tartibini pasaytirish usuli* hisoblanadi.

$y^{(n)} = f(x)$ **ko'rinishdagi tenglama**

O'ng tomoni kvadraturada integrallanuvchi, uzluksiz $f(x)$ funksiyadan iborat bo'lgan $y^{(n)} = f(x)$ tenglama bevosita integrallash orqali tartibi bittaga past bo'lgan va bitta ixtiyoriy o'zgarmasni o'z ichiga olgan differensial tenglamaga keltiriladi. Integrallash yana $n-1$ marta bajariladi va berilgan tenglamaning n ta ixtiyoriy o'zgarmasni o'z ichiga olgan umumiy yechimi topiladi:

$$y(x) = \int(\int(\dots\int f(x)dx))dx + C_1 \frac{x^{n-1}}{(n-1)!} + C_2 \frac{x^{n-2}}{(n-2)!} + \dots + C_n.$$

2-misol. $y''' = \frac{\ln x}{x^2}$ differensial tenglamaning umumiy yechimini toping.

☞ Tenglamaning o'ng tomoni faqat x ga bog'liq. Shu sababli

differensial tenglamaning chap va o'ng tomonlarini ketma-ket uch marta integrallaymiz:

$$y'' = \int \frac{\ln x}{x^2} dx = \left| \begin{array}{l} u = \ln x, \quad du = \frac{dx}{x} \\ dv = \frac{dx}{x^2}, \quad v = -\frac{1}{x} \end{array} \right| = -\frac{1}{x} \ln x + \int \frac{dx}{x^2} = -\frac{1}{x} \ln x - \frac{1}{x} + C_1,$$

$$y' = \int -\frac{1}{x} \ln x dx - \int \frac{dx}{x} + C_1 x = -\int \ln x d \ln x - \ln x + C_1 x = -\frac{1}{2} \ln^2 x - \ln x + C_1 x + C_2,$$

$$y = -\int \frac{1}{2} \ln^2 x dx - \int \ln x dx + \frac{1}{2} C_1 x^2 + C_2 x = \left| \begin{array}{l} u = \frac{1}{2} \ln^2 x, \quad du = \ln x \frac{dx}{x} \\ dv = dx, \quad v = x \end{array} \right| =$$

$$= -\frac{x}{2} \ln^2 x + \int \ln x dx - \int \ln x dx + \frac{1}{2} C_1 x^2 + C_2 x + C_3 = -\frac{x}{2} \ln^2 x + \frac{1}{2} C_1 x^2 + C_2 x + C_3. \quad \bullet$$

3-misol. $y''' = 60x^2$ tenglamaning [1;2] kesmada $y|_{x=1} = 9$, $y|_{x=2} = 34$, $y'|_{x=1} = 0$ chegaraviy shartlarni qanoatlantiruvchi xususiy yechimini toping.

☞ $y''' = 60x^2$ tenglamaning umumiy yechimini topish uchun uni ketma-ket uch marta integrallaymiz:

$$y'' = 20x^3 + C_1, \quad y' = 5x^4 + C_1 x + C_2, \quad y = x^5 + \frac{1}{2} C_1 x^2 + C_2 x + C_3.$$

C_1, C_2, C_3 o'zgarmaslarni chegaraviy shartlardan aniqlaymiz:

$$9 = 1 + \frac{1}{2} C_1 + C_2 + C_3, \quad 34 = 32 + 2C_1 + 2C_2 + C_3, \quad 0 = 5 + C_1 + C_2.$$

Bundan $C_1 = -2$, $C_2 = -3$, $C_3 = 12$.

Demak, izlanayotgan xususiy yechim

$$y = x^5 - x^2 - 3x + 12. \quad \bullet$$

$F(x, y^{(k)}, y^{(k+1)}, \dots, y^{(n)}) = 0$ ko'rinishdagi tenglama

Noma'lum funksiya va uning $(k-1)$ tartibgacha hosilalari oshkor qatnashmagan $F(x, y^{(k)}, y^{(k+1)}, \dots, y^{(n)}) = 0$ tenglamaning tartibi $y^{(k)} = p(x)$ o'rniga qo'yish orqali k birlikka pasaytiriladi:

$$F(x, p, p', p'', \dots, p^{(n-k)}) = 0.$$

Bu tenglamani integrallash mumkin bo'lsa, ya'ni

$$p = \varphi(x, C_1, C_2, \dots, C_{n-k}) \quad \text{yoki} \quad y^{(k)} = \varphi(x, C_1, C_2, \dots, C_{n-k})$$

yechim mavjud bo'lsa, izlanayotgan $y(x)$ funksiya $\varphi(x, C_1, C_2, \dots, C_{n-k})$ funksiyani k marta integrallash orqali topiladi.

4-misol. Koshi masalasini yeching: $y'' + y'tgx = \sin 2x$, $y(0) = 3$, $y'(0) = 1$.

☞ Tenglamada y oshkor qatnashmaydi. Shu sababli $y' = p(x)$, $y'' = p'$ almashtirishlar bajaramiz.

U holda

$$p' + ptgx = \sin 2x$$

birinchi tartibli chiziqli tenglama kelib chiqadi. Bunda $P(x) = tgx$, $Q(x) = \sin 2x$.

Bu tenglamani yechamiz:

$$\begin{aligned} p &= e^{-\int tgx dx} (\sin 2x \cdot e^{\int tgx dx} dx + C_1) = e^{\ln|\cos x|} (\int \sin 2x \cdot e^{-\ln|\cos x|} dx + C_1) = \\ &= \cos x (\int \sin 2x dx + C_1) = \cos x (-2 \cos x + C_1) = C_1 \cos x - 2 \cos^2 x. \end{aligned}$$

yoki

$$y' = C_1 \cos x - 2 \cos^2 x.$$

$y'(0) = 1$ boshlang'ich shartdan topamiz: $1 = C_1 - 2$, $C_1 = 3$.

U holda

$$y' = 3 \cos x - 2 \cos^2 x$$

bo'ladi. Tenglamani integrallaymiz:

$$y = 3 \sin x - x - \frac{\sin 2x}{2} + C_2.$$

$y(0) = 3$ boshlang'ich shartdan topamiz: $3 = C_2$.

Demak, berilgan Koshi masalasining yechimi

$$y = 3 \sin x - x - \sin x \cos x + 3. \quad \text{☞}$$

5-misol. $xy''' - y'' = 0$ differensial tenglamaning umumiy yechimini toping.

☞ Tenglamada y va y' qatnashmaydi. Shu sababli $y'' = p(x)$, $y''' = p'$ almashtirishlar bajaramiz.

U holda

$$xp' - p = 0$$

birinchi tartibli o'zgaruvchilari ajraladigan tenglama kelib chiqadi.

Bu tenglamani yechamiz:

$$\frac{dp}{p} = \frac{dx}{x}, \quad \ln |p| = \ln |x| + \ln C_1, \quad p = C_1 x.$$

Bundan $y'' = C_1 x$.

Oxirgi tenglamani ketma-ket ikki marta integrallab, berilgan tenglamaning umumiy yechimini topamiz:

$$y = \frac{1}{6} C_1 x^3 + C_2 x + C_3. \quad \text{☞}$$

$F(y, y', y'', \dots, y^{(n)}) = 0$ ko'rinishdagi tenglama

x erkli o'zgaruvchi oshkor qatnashmagan $F(y, y', y'', \dots, y^{(n)}) = 0$ tenglamaning tartibini pasaytirish uchun $y' = p(y)$ o'rniga qo'yish orqali yangi noma'lum funksiya $p(y)$ va yangi erkli o'zgaruvchi y kiritiladi.

Bunda barcha $y^{(k)} = \frac{\partial^k y}{\partial x^k}$, $k = 1, 2, \dots, n$ hosilalar p funksiyaning y bo'yicha

hosilalari bilan almashtiriladi: $y' = \frac{dy}{dx} = p$, $y'' = \frac{dp}{dx} = \frac{dp}{dy} \cdot \frac{dy}{dx} = p \frac{dp}{dy}$,

$y''' = \frac{d}{dx} \left(p \frac{dp}{dy} \right) = \frac{d}{dy} \left(p \frac{dp}{dy} \right) \cdot \frac{dy}{dx} = p \left(\frac{dp}{dy} \cdot \frac{dp}{dy} + p \cdot \frac{d^2 p}{dy^2} \right) = p^2 \frac{d^2 p}{dy^2} + p \left(\frac{dp}{dy} \right)^2$ va

hokazo.

Bunda har qanday k -tartibli $y^{(k)} = \frac{\partial^k y}{\partial x^k}$ hosila tartibi $(k-1)$ dan katta bo'lmagan p funksiyaning y bo'yicha hosilalari bilan ifodalanadi. Shu sababli $y', y'', \dots, y^{(n-1)}$ hosilalar berilgan tenglamaga qo'yilganda, uning tartibi bittaga pasayadi.

6-misol. $y'y''' - 3(y'')^2 = 0$ differensial tenglamaning umumiy yechimini toping.

☞ Tenglamada x oshkor qatnashmaydi.

Shu sababli $y' = p(y)$ almashtirish bajaramiz. Bundan

$$y'' = p \frac{dp}{dy}, \quad y''' = p^2 \frac{d^2 p}{dy^2} + p \left(\frac{dp}{dy} \right)^2.$$

U holda berilgan tenglamadan

$$p^2 \left(p \frac{d^2 p}{dy^2} - 2 \left(\frac{dp}{dy} \right)^2 \right) = 0$$

tenglik kelib chiqadi. Bu tenglikni p^2 ga bo'lamiz (bunda $p = 0$ yoki $y = C$ yechim tushib qoladi):

$$p \frac{d^2 p}{dy^2} - 2 \left(\frac{dp}{dy} \right)^2 = 0.$$

Bu tenglamada $\frac{dp}{dy} = t$, $\frac{d^2 p}{dy^2} = t \frac{dt}{dp}$ o'rniga qo'yishlarni bajaramiz:

$$pt \frac{dt}{dp} - 2t^2 = 0.$$

Bu tenglikni t ga bo‘lamiz (bunda $t = \frac{dp}{dy} = 0$ yoki $y = C_3x + C_4$ yechim tushib qolishi mumkin; bu yechim avval tushib qolgan $C = 0$ yechimni o‘z ichiga oladi):

$$\frac{dt}{t} - 2\frac{dp}{p} = 0.$$

Bundan $t = C_1p^2$ yoki $\frac{dp}{dy} = C_1p^2$. Bu tenglikni integrallaymiz:

$$-\frac{1}{p} = C_1y + C_2 \quad \text{yoki} \quad -\frac{dx}{dy} = C_1y + C_2.$$

Bundan

$$x = -\frac{1}{2}C_1y^2 - C_2y + C_3.$$

Demak, berilgan tenglamaning yechimlari

$$x = -\frac{1}{2}C_1y^2 - C_2y + C_3, \quad y = C_3x + C_4. \quad \blacktriangleleft$$

7-misol. $y'' = \sqrt{1 - (y')^2} = 0$ differensial tenglamaning umumiy yechimini toping.

☞ Tenglamada x va y oshkor qatnashmaydi. Shu sababli $y' = p(y)$ va $y' = p(x)$ o‘rniga qo‘yishlardan birini bajarish mumkin. Bunday hollarda soddaroq yechimga olib keluvchi almashtirish bajariladi. Shu sababli $y' = p(x)$, $y'' = p'$ deymiz. U holda

$$p' = \sqrt{1 - p^2}$$

tenglama kelib chiqadi.

Bu tenglamani yechamiz:

$$\frac{dp}{\sqrt{1 - p^2}} = dx, \quad \arcsin p = x + C_1, \quad p = \sin(x + C_1).$$

Bundan

$$y' = \sin(x + C_1) \quad \text{yoki} \quad y = -\cos(x + C_1) + C_2. \quad \blacktriangleleft$$

$\frac{d}{dx}F(y, y', y'', \dots, y^{(n-1)}) = 0$ **ko‘rinishdagi tenglama**

Chap tomoni x ning biror funksiyasi to‘liq differensialidan iborat bo‘lgan $\frac{d}{dx}F(y, y', y'', \dots, y^{(n-1)}) = 0$ tenglamani ng tartibi x bo‘yicha integrallash orqali bittaga kamaytiriladi.

8-misol. Koshi masalasini yeching: $yy'' - (y')^2 = 0$, $y(0) = 1$, $y'(0) = 2$.

☞ Tenglamani $y^2 \neq 0$ ga bo'lamiz: $\frac{yy'' - y'^2}{y^2} = 0$. Bu tenglamaning chap tomoni $\frac{y'}{y}$ ifodaning to'liq differensialidan iborat. Shu sababli berilgan

tenglamadan $d\left(\frac{y'}{y}\right) = 0$ tenglama kelib chiqadi. Bu tenglamani yechamiz:

$$\frac{y'}{y} = C_1, \quad \frac{dy}{y} = C_1 dx, \quad \ln y = C_1 x + \ln C_2, \quad y = C_2 e^{C_1 x}.$$

C_1, C_2 o'zgarmlarini boshlang'ich shartlardan aniqlaymiz: $C_1 = 2$, $C_2 = 1$.

Bundan $y = e^{2x}$ kelib chiqadi.

Nolga teng emas deb faraz qilingan $y = 0$ berilgan tenglamaning yechimi bo'ladimi? Buni tekshiramiz: $y = C$ tenglamaning yechimi bo'ladi, chunki $y = 0$ berilgan tenglamaga qo'yilsa, $0 \equiv 0$ ayniyat hosil bo'ladi. Bu yechim berilgan Koshi masalasining yechimi bo'lmaydi, chunki misolning shartiga ko'ra $y(0) = 1$.

Demak, berilgan Koshi masalasining yechimi: $y = e^{2x}$. ☝

9-misol. $y'y'' = y'(y' + 1)$ differensial tenglamaning umumiy yechimini toping.

☞ Tenglamani $y(y' + 1) \neq 0$ ga bo'lamiz:

$$\frac{y''}{y' + 1} = \frac{y'}{y}.$$

Oxirgi tenglamani

$$d \ln(y' + 1) = d \ln y$$

ko'rinishda yozish mumkin. Bundan

$$\ln(y' + 1) = \ln y + \ln C_1 \quad \text{yoki} \quad y' + 1 = C_1 y.$$

Bu tenglamani yechamiz:

$$\frac{dy}{dx} = C_1 y - 1, \quad \frac{dy}{C_1 y - 1} = dx, \quad \frac{dy}{C_1 y - 1} = dx, \quad \frac{1}{C_1} \ln|C_1 y - 1| = x + \ln C_2,$$

$$y = \frac{1}{C_1} + C_2 e^{C_1 x}.$$

Nolga teng emas deb faraz qilingan $y = 0$ va $y' + 1 = 0$ (yoki $y = -x + C_1$) berilgan tenglamaning yechimlari bo'ladi, chunki har ikkala holda yechimlar tenglamaga qo'yilsa, $0 \equiv 0$ ayniyat hosil bo'ladi. ☝

Noma'lum funksiya va uning hosilalariga nisbatan bir jinsli bo'lgan

$F(x, y, y', \dots, y^{(n)}) = 0$ ko'rinishdagi tenglama

Chap tomoni noma'lum funksiya va uning hosilalariga nisbatan bir jinsli funksiyadan iborat, ya'ni $F(x, tx, ty', \dots, ty^{(n)}) = t^n F(x, y, y', \dots, y^{(n)})$ bo'lgan

$F(x, y, y', \dots, y^{(n)}) = 0$ tenglamaning tartibini pasaytirish uchun $y' = yz$ o'rniga qo'yish bajariladi hamda y'', y''' va boshqa hosilalar topiladi:

$$y'' = (yz)' = y'z + yz' = yz^2 + yz' = y(z^2 + z'); \quad y''' = y(z^3 + 3zz' + z'')$$

Bunda hosilalarning har biri y ko'paytuvchini o'z ichiga oladi. Berilgan tenglamaning chap tomoni bir jinsli funksiya bo'lgani uchun y, y', y'', \dots lar ty, ty', ty'', \dots lar bilan almashtirilganda bu funksiya o'zgarmaydi. Shu sababli

$t = \frac{1}{y}$ o'rniga qo'yish orqali tenglamadan y ni yo'qotish mumkin bo'ladi va

tenglamaning tartibi bittaga pasayadi.

10-misol. $x^2 yy' - (y - xy')^2 = 0$ differensial tenglamaning umumiy yechimini toping.

☞ Tenglamani chap tomoni y, y', y'' larga nisbatan bir jinsli, chunki

$$F(x, ty, ty', ty'') = x^2 ty ty'' - (ty - txy')^2 = t^2 (x^2 yy' - (y - xy')^2) = t^2 F(x, y, y', y'').$$

Shu sababli $y' = yz$ va $y'' = y(z^2 + z')$ o'rniga qo'yishlar bajaramiz.

U holda berilgan tenglamadan

$$x^2 y^2 (z^2 + z') - (y - xyz)^2 = 0 \quad \text{yoki} \quad y^2 (x^2 (z^2 + z') - (1 - xz)^2) = 0$$

kelib chiqadi.

$y = 0$ berilgan tenglamaning yechimi bo'ladi. $y \neq 0$ da topamiz:

$$x^2 z^2 + x^2 z' - 1 + 2xz - x^2 z^2 = 0.$$

Bundan

$$z' + \frac{2}{x}z = \frac{1}{x^2}.$$

Tenglamani yechamiz:

$$z = e^{-\int \frac{2dx}{x}} \left(\int \frac{1}{x^2} e^{\int \frac{2dx}{x}} dx + C_1 \right) = \frac{1}{x} + \frac{C_1}{x^2}.$$

U holda $y' = yz$ dan $y = C_2 e^{\int z dx}$ kelib chiqadi. Bundan

$$y = C_2 e^{\int z dx} = C_2 e^{\int \left(\frac{1}{x} + \frac{C_1}{x^2} \right) dx} \quad \text{yoki}$$

$$y = C_2 x e^{-\frac{C_1}{x}}. \quad \text{☞}$$

Mashqlar

3.2.1. $-ctgy = C_1x + C_2$ ifoda $y''tgy = 2(y')^2$ differensial tenglamaning yechimi ekanini ko'rsating.

3.2.2. $3y - (C_1 - 2x)^{\frac{3}{2}} = C_2x + C_3$ ifoda $y''' = (y'')^3$ differensial tenglamaning yechimi ekanini ko'rsating.

3.2.3. $y'' = y' \ln y'$ differensial tenglama yechimining mavjudlik va yagonalik sohasini toping.

3.2.4. $y'' = x + \sqrt{x^2 - y'}$ differensial tenglama yechimining mavjudlik va yagonalik sohasini toping.

3.2.5. Differensial tenglamalarni yeching:

- | | |
|---------------------------------|--------------------------------|
| 1) $y'' = \frac{1}{1+x^2}$; | 2) $y'' = x \ln x$; |
| 3) $y''' = \cos 2x$; | 4) $y'''' = e^{3x}$; |
| 5) $2xy'y'' = (y')^2 + 1$; | 6) $x \ln xy'' - y' = 0$; |
| 7) $x(y'' + 1) + y' = 0$; | 8) $yy'' + (y')^2 = e^x x^2$; |
| 9) $yy'' - (y')^2 = y^2 y'$; | 10) $y'' + 2y(y')^3 = 0$; |
| 11) $yy'' + (y')^2 = 1$; | 12) $yy'' = (y')^2 - (y')^3$; |
| 13) $(1+x^2)y'' + 2xy' = x$; | 14) $x^2 y'' = xy' - y$; |
| 15) $yy'' + (y')^2 = x$; | 16) $xy''' + y'' = 2x - 1$; |
| 17) $xyy'' - y'(xy' + y) = 0$; | 18) $2yy'' - 3(y')^2 = 4y^2$. |

3.2.6. Koshi masalasini yeching:

- | | |
|--|---|
| 1) $y'' = \frac{1}{\cos^2 x}$, $y\left(\frac{\pi}{4}\right) = \frac{\ln 2}{2}$; $y'\left(\frac{\pi}{4}\right) = 1$; | 2) $y'' = x \sin x$, $y(0) = -2$; $y'(0) = 1$; |
| 3) $y'''(x-1) - y'' = 0$, $y(2) = 2$; $y'(2) = 1$, $y''(2) = 1$; | 4) $y'' = \frac{y'}{x} + \frac{x^2}{y'}$, $y(2) = 0$; $y'(2) = 4$; |
| 5) $y''tgy = 2(y')^2$, $y\left(\frac{\pi}{2}\right) = \frac{\pi}{2}$; $y'\left(\frac{\pi}{2}\right) = 1$; | 6) $y'' = e^{2y}$, $y(0) = 0$; $y'(0) = 1$; |
| 7) $xyy'' + x(y')^2 = yy'$, $y(1) = y'(1) = 3$; | 8) $yy'' - (y')^2 = y^2$, $y(0) = 1$; $y'(0) = 0$. |

3.3. CHIZIQLI BIR JINSLI DIFFERENSIAL TENGLAMALAR

**Ikkinchi tartibli chiziqli bir jinsli differensial tenglamalar.
Ikkinchi tartibli chiziqli bir jinsli o'zgarmas koeffitsiyentli
differensial tenglamalar. Yuqori tartibli chiziqli
bir jinsli differensial tenglamalar**

3.3.1. Ushbu

$$y'' + p(x)y' + q(x)y = 0 \quad (3.1)$$

ko'rinishdagi tenglamaga *ikkinchi tartibli chiziqli bir jinsli differensial tenglama* deyiladi, bu yerda $p(x)$, $q(x)$ – erkli o'zgaruvchi x ning uzluksiz funksiyalari.

Agar (3.1) tenglamaning $y_1(x)$ va $y_2(x)$ yechimlari uchun kamida bittasi nolga teng bo'lmagan shunday α_1 , α_2 o'zgarmaslar topilsa va istalgan $x \in (a;b)$ da

$$\alpha_1 y_1(x) + \alpha_2 y_2(x) = 0 \quad (3.2)$$

tenglik bajarilsa, $y_1(x)$ va $y_2(x)$ yechimlarga $(a;b)$ intervalda *chiziqli bog'liq yechimlar* deyiladi.

Agar istalgan $x \in (a;b)$ uchun (3.2) tenglik faqat $\alpha_1 = \alpha_2 = 0$ bo'lganda bajarilsa, $y_1(x)$ va $y_2(x)$ yechimlarga $(a;b)$ intervalda *chiziqli erkin yechimlar* deyiladi.

(3.1) tenglamaning $y_1(x)$ va $y_2(x)$ chiziqli erkin yechimlari to'plamiga bu tenglamaning *fundamental yechimlari sistemasi* deyiladi.

$y_1(x)$ va $y_2(x)$ yechimlar va ularning hosilalaridan tuzilgan

$$W(x) = W(y_1, y_2) = \begin{vmatrix} y_1(x) & y_2(x) \\ y_1'(x) & y_2'(x) \end{vmatrix} \quad (3.3)$$

determinantga *Vronskiy determinanti* (yoki vronskian) deb ataladi.

1-teorema. Agar (3.1) tenglamaning $y_1(x)$ va $y_2(x)$ yechimlari $[a;b]$ kesmada chiziqli bog'liq bo'lsa, u holda istalgan $x \in [a;b]$ da $W(x) = 0$ bo'ladi.

2-teorema. Agar $y_1(x)$ va $y_2(x)$ $[a;b]$ kesmada (3.1) tenglamaning chiziqli erkin yechimlari bo'lsa, u holda Vronskiy determinanti bu kesmaning hech bir nuqtasida nolga teng bo'lmaydi.

1-misol. Berilgan funksiyalarni chiziqli bog‘liqlikka tekshiring:

1) $y_1 = \arctg x$ va $y_2 = \text{arcctg} x$; 2) $y_1 = 1 + \cos 2x$ va $y_2 = \cos^2 x$.

☞ 1) $y_1 = \arctg x$ va $y_2 = \text{arcctg} x$ funksiyalar $x \in (-\infty; +\infty)$ aniqlangan.

Vronskianni hisoblaymiz:

$$W(y_1, y_2) = \begin{vmatrix} \arctg x & \text{arcctg} x \\ \frac{1}{1+x^2} & -\frac{1}{1+x^2} \end{vmatrix} =$$

$$= -\frac{1}{1+x^2}(\arctg x + \text{arcctg} x) = -\frac{\pi}{2(1+x^2)} \neq 0, \quad \forall x \in R.$$

Demak, $\arctg x$ va $\text{arcctg} x$ funksiyalar $x \in R$ da chiziqli erkin bo‘ladi.

2) $y_1 = 1 + \cos 2x$ va $y_2 = \cos^2 x$ funksiyalar $x \in (-\infty; +\infty)$ aniqlangan. Bunda

$$W(y_1, y_2) = \begin{vmatrix} 1 + \cos 2x & \cos^2 x \\ -2 \sin 2x & -2 \cos x \sin x \end{vmatrix} =$$

$$= (1 + \cos 2x)(-2 \sin 2x) + 2 \cos^2 x \sin 2x = -2 \cos^2 x \sin 2x + 2 \cos^2 x \sin 2x = 0.$$

Demak, $1 + \cos 2x$ va $\cos^2 x$ funksiyalar $x \in R$ da chiziqli bog‘liq bo‘ladi. ☹

⇒ Agar $y_1(x)$ va $y_2(x)$ xususiy yechimlar $[a, b]$ kesmada fundamental sistema tashkil qilsa, istalgan $x \in [a, b]$ da $\frac{y_2(x)}{y_1(x)} \neq \text{const}$ bo‘ladi.

3-teorema. Agar (3.1) tenglamaning ikkita $y_1(x)$ va $y_2(x)$ xususiy yechimi $[a, b]$ kesmada fundamental sistema tashkil qilsa, u holda (3.1) tenglamaning umumiy yechimi

$$y(x) = C_1 y_1(x) + C_2 y_2(x), \tag{3.4}$$

ko‘rinishda bo‘ladi, bu yerda C_1, C_2 – ixtiyoriy o‘zgarmaslar.

2-misol. $y_1 = x$ va $y_2 = x^2$ funksiyalar $y'' - \frac{2}{x}y' + \frac{2}{x^2}y = 0$ tenglamaning fundamental yechimlari sistemasini tashkil etishini ko‘rsating va tenglamaning umumiy yechimini toping.

☞ $y_1 = x$ va $y_2 = x^2$ larni $y'' - \frac{2}{x}y' + \frac{2}{x^2}y = 0$ tenglamaga qo‘yamiz:

$$y_1 = x \text{ da } x'' - \frac{2}{x}x' + \frac{2}{x^2}x = 0 - \frac{2}{x} \cdot 1 + \frac{2}{x} = 0;$$

$$y_2 = x^2 \text{ da } (x^2)'' - \frac{2}{x}(x^2)' + \frac{2}{x^2}x^2 = 2 - \frac{2}{x} \cdot 2x + 2 = 0.$$

Demak, $y_1 = x$ va $y_2 = x^2$ funksiyalar $y'' - \frac{2}{x}y' + \frac{2}{x^2}y = 0$ tenglamaning

xususiy yechimlari bo‘ladi.

Berilgan tenglamada $p(x) = -\frac{2}{x}$, $q(x) = \frac{2}{x^2}$. Shu sababli $y_1 = x$ va $y_2 = x^2$ yechimlarning yagonalik sohasi $D = \{(x, y) : x \neq 0\}$. D sohada $\frac{y_2}{y_1} = \frac{x^2}{x} = x \neq const$. Demak, $y_1 = x$ va $y_2 = x^2$ yechimlar fundamental sistema tashkil qiladi va berilgan tenglamaning umumiy yechimi

$$y = C_1 x + C_2 x^2. \quad \odot$$

\Rightarrow (3.1) tenglamaning umumiy yechimini topish uchun uning fundamental sistema tashkil qiluvchi ikkita xususiy yechimini bilish yetarli bo‘ladi.

Agar xususiy yechimlardan bittasi y_1 berilgan bo‘lsa, y_2 yechim

$$y_2 = y_1 \int \frac{1}{y_1^2} e^{-\int_{x_0}^x p(x) dx} dx \quad (3.5)$$

formula bilan aniqlanadi.

3-misol. $y'' - \frac{2x}{1-x^2} y' + \frac{2}{1-x^2} y = 0$ tenglamaning $y_1 = x$ xususiy yechimi ma'lum bo‘lsa, uning umumiy yechimini toping.

\odot Berilgan tenglamada $p(x) = -\frac{2x}{1-x^2}$, $q(x) = \frac{2}{1-x^2}$ va yechimlarning yagonalik sohasi $D = \{(x, y) : x \neq -1, x \neq 1\}$.

Ikkinchi xususiy yechimni (3.5) formula bilan topamiz:

$$\begin{aligned} y_2 &= x \int \frac{1}{x^2} e^{\int_0^x \frac{2x}{1-x^2} dx} dx = x \int \frac{1}{x^2} e^{-\ln|1-x^2|} dx = x \int \frac{dx}{x^2(1-x^2)} = x \int \left(\frac{1}{x^2} + \frac{1}{1-x^2} \right) dx = \\ &= x \left(-\frac{1}{x} + \frac{1}{2} \ln \left| \frac{1+x}{1-x} \right| \right) = \frac{x}{2} \ln \left| \frac{1+x}{1-x} \right| - 1. \end{aligned}$$

Bunda xususiy yechim izlanayotgani uchun integrallash o‘zgarmasi nolga teng deb olindi.

$y_1 = x$ va $y_2 = \frac{x}{2} \ln \left| \frac{1+x}{1-x} \right| - 1$ yechimlar uchun $\frac{y_2}{y_1} = \frac{x}{2} \ln \left| \frac{1+x}{1-x} \right| - \frac{1}{x} \neq const$.

Demak, yechimlar fundamental sistema tashkil qiladi va tenglamaning umumiy yechimi

$$y = C_1 x + C_2 \left(\frac{x}{2} \ln \left| \frac{1+x}{1-x} \right| - 1 \right). \quad \odot$$

4-misol. Bir jinsli chiziqli ikkinchi tartibli differensial tenglamaning fundamental yechimlari $y_1 = x$ va $y_2 = e^{2x}$ dan iborat. Bu tenglamani tuzing.

☞ Berilgan yechimlar uchun vronskianni tuzamiz:

$$W(x) = \begin{vmatrix} x & e^{2x} \\ 1 & 2e^{2x} \end{vmatrix} = 2xe^{2x} - e^{2x} = e^{2x}(2x - 1).$$

Demak, yechimlarning yagonalik sohasi $D = \left\{ (x, y) : x \neq \frac{1}{2} \right\}$.

D sohada tenglamaning umumiy yechimi $y = C_1x + C_2e^{2x}$ bo'ladi.

Bundan $y' = C_1 + 2C_2e^{2x}$, $y'' = 4C_2e^{2x}$. Bu tengliklardan topamiz:

$$C_1 = \frac{1}{2}(2y' - y''), \quad C_2 = \frac{1}{4}e^{-2x}y''.$$

C_1 va C_2 ning topilgan qiymatlarini $y = C_1x + C_2e^{2x}$ ifodaga qo'yib, almashtirishlar bajaramiz:

$$y = (2y' - y'')x + \frac{1}{4}e^{-2x}y''e^{2x}, \quad 4y = 4xy' - 2xy'' + y'',$$

$$y''(1 - 2x) + 4xy' - 4y = 0, \quad y'' + \frac{4x}{1 - 2x}y' - \frac{4}{1 - 2x}y = 0.$$

Demak, izlanayotgan tenglama

$$y'' + \frac{4x}{1 - 2x}y' - \frac{4}{1 - 2x}y = 0. \quad \text{☞}$$

3.3.2. (3.1) tenglamaning xususiy holi bo'lgan

$$y'' + py' + qy = 0 \tag{3.6}$$

tenglamaga *ikkinchi tartibli chiziqli bir jinsli o'zgarmas koeffitsiyentli differensial tenglama* deyiladi, bu yerda p, q – o'zgarmas haqiqiy sonlar.

Ushbu

$$k^2 + pk + q = 0. \tag{3.7}$$

algebraik tenglamaga (3.7) differensial tenglamaning *xarakteristik tenglamasi* deyiladi.

k_1 va k_2 (3.7) xarakteristik tenglamaning ildizi bo'lsin.

U holda (3.6) differensial tenglamaning yechimi quyidagi uch formuladan biri bilan topiladi:

1) agar k_1 va k_2 – haqiqiy va $k_1 \neq k_2$ bo'lsa, u holda

$$y = C_1e^{k_1x} + C_2e^{k_2x}; \tag{3.8}$$

2) agar $k_1 = k_2 = k$ bo'lsa, u holda

$$y = e^{kx}(C_1 + C_2x); \tag{3.9}$$

3) agar $k_1 = \alpha + i\beta$ va $k_2 = \alpha - i\beta$ – kompleks-*qo'shma* bo'lsa, u holda

$$y = e^{\alpha x} (C_1 \cos \beta x + C_2 \sin \beta x). \quad (3.10)$$

5-misol. Differensial tenglamaning umumiy yechimini toping:

1) $y'' + 3y' + 2y = 0$; 2) $y'' - 6y' + 9y = 0$; 3) $y'' + 2y' + 5y = 0$.

☉ 1) Ikkinchi tartibli chiziqli bir jinsli o'zgarmas koeffitsiyentli differensial tenglama berilgan.

Uning xarakteristik tenglamasini tuzamiz:

$$k^2 + 3k + 2 = 0.$$

Bu tenglama haqiqiy va har xil ildizlarga ega: $k_1 = -1, k_2 = -2$.

U holda uning umumiy yechimi

$$y = C_1 e^{-x} + C_2 e^{-2x}$$

ko'rinishda bo'ladi.

2) Tenglamaning xarakteristik tenglamasini tuzamiz:

$$k^2 - 6k + 9 = 0.$$

Bu tenglama ikkita bir xil haqiqiy ildizga ega: $k_1 = k_2 = k = 3$.

Demak, tenglamaning umumiy yechimi

$$y = e^{3x} (C_1 + C_2 x).$$

3) $k^2 + 2k + 5 = 0$ xarakteristik tenglama $k_1 = -1 + 2i$ va $k_2 = -1 - 2i$ ildizlarga ega. Bundan $\alpha = -1$ va $\beta = 2$.

U holda tenglamaning umumiy yechimi

$$y = e^{-x} (C_1 \cos 2x + C_2 \sin 2x)$$

ko'rinishda bo'ladi. ☉

3.3.3. Ikkinchi tartibli chiziqli bir jinsli differensial tenglama uchun qabul qilingan ta'riflar va olingan natijalarni

$$y^{(n)} + a_1(x)y^{(n-1)} + \dots + a_{n-1}(x)y' + a_n(x)y = 0 \quad (3.11)$$

ko'rinishdagi $n - (n > 2)$ tartibli chiziqli bir jinsli differensial tenglama uchun tatbiq etish mumkin.

Xususan:

1. Agar (3.11) tenglamaning y_1, y_2, \dots, y_n yechimlari uchun kamida bittasi nolga teng bo'lmagan shunday $\alpha_1, \alpha_2, \dots, \alpha_n$ o'zgarmaslar topilsa va istalgan $x \in (a; b)$ da

$$\alpha_1 y_1 + \alpha_2 y_2 + \dots + \alpha_n y_n = 0 \quad (3.12)$$

tenglik bajarilsa, y_1, y_2, \dots, y_n yechimlarga *chiziqli bog'liq yechimlar* deyiladi.

Agar istalgan $x \in (a; b)$ uchun (3.12) tenglik faqat $\alpha_1 = \alpha_2 = \dots = \alpha_n = 0$ uchun bajarilsa, y_1, y_2, \dots, y_n yechimlarga $(a; b)$ intervalda chiziqli erkin yechimlar deyiladi.

2. (3.11) tenglamaning chiziqli erkin y_1, y_2, \dots, y_n yechimlari to'plamiga bu tenglamaning *fundamental yechimlari sistemasi* deyiladi.

3. y_1, y_2, \dots, y_n yechimlar va ularning hosilalaridan tuzilgan

$$W(x) = \begin{vmatrix} y_1 & y_2 & \dots & y_n \\ y_1' & y_2' & \dots & y_n' \\ y_1'' & y_2'' & \dots & y_n'' \\ \dots & \dots & \dots & \dots \\ y_1^{(n-1)} & y_2^{(n-1)} & \dots & y_n^{(n-1)} \end{vmatrix} \quad (3.13)$$

determinantga *Vronskiy determinanti* (yoki vronskian) deyiladi.

4. Agar y_1, y_2, \dots, y_n $[a; b]$ kesmada (3.11) tenglamaning fundamental yechimlarini tashkil qilsa, barcha $x \in (a; b)$ da $W(x) \neq 0$ bo'ladi.

5. Agar (3.11) tenglamaning y_1, y_2, \dots, y_n xususiy yechimlari $[a; b]$ kesmada fundamental sistema tashkil qilsa, bu tenglamaning umumiy yechimi

$$y = C_1 y_1 + C_2 y_2 + \dots + C_n y_n \quad (3.14)$$

ko'rinishda bo'ladi, bu yerda C_1, C_2, \dots, C_n – ixtiyoriy o'zgarmaslar.

6. Agar (3.11) tenglama o'zgarmas koeffitsiyentli, ya'ni

$$y^{(n)} + a_1 y^{(n-1)} + \dots + a_{n-1} y' + a_n y = 0 \quad (3.15)$$

ko'rinishda bo'lsa u holda uning y_1, y_2, \dots, y_n xususiy yechimlari

$$k^n + a_1 k^{n-1} + \dots + a_{n-1} k + a_n = 0 \quad (3.16)$$

xarakteristik tenglama yordamida topiladi, bu yerda a_1, a_2, \dots, a_n – o'zgarmas haqiqiy sonlar.

Bunda (3.16) xarakteristik tenglamaning har bir m karrali haqiqiy k ildiziga (3.15) tenglamaning m ta chiziqli erkin $e^{kx}, x e^{kx}, \dots, x^{m-1} e^{kx}$ yechimlari mos keladi, xarakteristik tenglamaning har bir r karrali kompleks-qo'shma $k_1 = \alpha + i\beta, k_2 = \alpha - i\beta$ ildizlari juftiga (3.15) tenglamaning $2r$ ta chiziqli erkin $e^{\alpha x} \cos \beta x, e^{\alpha x} \sin \beta x, x e^{\alpha x} \cos \beta x, x e^{\alpha x} \sin \beta x, \dots, x^{r-1} e^{\alpha x} \cos \beta x, x^{r-1} e^{\alpha x} \sin \beta x$ yechimlari mos keladi.

5-misol. $y^y - y''' - y'' + y = 0$ differensial tenglamaning umumiy yechimini toping.

☞ Beshinchi tartibli chiziqli bir jinsli o'zgarmas koeffitsiyentli tenglama berilgan. Tenglamaning xarakteristik tenglamasini tuzamiz:

$$k^5 - k^3 - k^2 + 1 = 0 \text{ yoki } (k+1)(k-1)^2(k^2+k+1) = 0.$$

$$\text{Bundan } k_1 = -1, k_{2,3} = 1, k_4 = -\frac{1}{2} + \frac{\sqrt{3}}{2}i, k_5 = -\frac{1}{2} - \frac{\sqrt{3}}{2}i.$$

Tenglamaning $k_1 = -1$ ildiziga $y_1 = e^{-x}$ yechim, ikki karrali $k_{2,3} = 1$

ildiziga $y_2 = e^x, y_3 = xe^x$ yechimlar va $k_4 = -\frac{1}{2} + \frac{\sqrt{3}}{2}i, k_5 = -\frac{1}{2} - \frac{\sqrt{3}}{2}i$ ildizlar

juftga $y_4 = e^{\frac{1}{2}x} \cos \frac{\sqrt{3}}{2}x, y_5 = e^{\frac{1}{2}x} \sin \frac{\sqrt{3}}{2}x$ yechimlar mos keladi.

Demak, tenglamaning umumiy yechimi:

$$y = C_1 e^{-x} + e^x (C_2 + C_3 x) + e^{\frac{1}{2}x} \left(C_4 \cos \frac{\sqrt{3}}{2}x + C_5 \sin \frac{\sqrt{3}}{2}x \right). \quad \text{☞}$$

Mashqlar

3.3.1. Berilgan funksiyalarni chiziqli bog'liqlikka tekshiring:

- 1) $y_1 = \arcsin x$ va $y_2 = \arccos x$;
- 2) $y_1 = \sqrt{1 - \cos 2x}$ va $y_2 = \sin x$;
- 3) $y_1 = e^x$, va $y_2 = e^{x+2}$;
- 4) $y_1 = chx$ va $y_2 = shx$.

3.3.2. y_1 va y_2 funksiyalar berilgan tenglamaning fundamental yechimlari sistemasini tashkil etishini ko'rsating va tenglamaning umumiy yechimini toping:

$$1) y_1 = x \text{ va } y_2 = x^2 - 1, \quad y'' - \frac{2x}{x^2+1}y' + \frac{2}{x^2+1}y = 0;$$

$$2) y_1 = x^3 \text{ va } y_2 = x^4, \quad y'' - \frac{6}{x}y' + \frac{12}{x^2}y = 0;$$

$$3) y_1 = e^{2x} \text{ va } y_2 = xe^{2x}, \quad y'' - 4y' + 4y = 0;$$

$$4) y_1 = \sin x \text{ va } y_2 = \cos x, \quad y'' + y = 0.$$

3.3.3. Berilgan tenglamaning y_1 xususiy yechimi ma'lum bo'lsa, uning umumiy yechimini toping:

$$1) y'' + \frac{2}{x}y' + y = 0, \quad y_1 = \frac{\cos x}{x};$$

$$2) y'' - \frac{2}{\sin^2 x}y = 0, \quad y_1 = ctgx;$$

$$3) y'' - 2y' - 3y = 0, \quad y_1 = e^{-x};$$

$$4) y'' + 4y = 0, \quad y_1 = \sin 2x.$$

3.3.4. Berilgan fundamental yechimlar sistemasiga ko‘ra bir jinsli chiziqli ikkinchi tartibli differensial tenglamani tuzing:

1) $y_1 = x$ va $y_2 = x^3$;

2) $y_1 = 1$ va $y_2 = \sin x$;

3) $y_1 = e^{3x}$ va $y_2 = xe^{3x}$;

4) $y_1 = \cos \frac{3}{2}x$ va $y_2 = \sin \frac{3}{2}x$.

3.3.5. Differensial tenglamaning umumiy yechimini toping:

1) $y'' - y' - 6y = 0$;

2) $y'' - 2y' - 2y = 0$;

3) $y'' - 4y' + 4y = 0$;

4) $9y'' + 6y' + y = 0$

5) $y'' + 4y' + 29y = 0$;

6) $4y'' - 8y' + 5y = 0$;

7) $y''' + y'' - 2y' = 0$;

8) $y''' - 5y'' + 17y' - 13y = 0$

9) $y^{IV} + 8y''' + 16y'' = 0$;

10) $y^V - 6y^{IV} + 9y''' = 0$.

3.3.6. Differensial tenglamaning xususiy yechimini toping:

1) $y'' + 5y' + 6y = 0$, $y(0) = 1$, $y'(0) = -6$;

2) $y'' - 8y' + 16y = 0$, $y(0) = 0$, $y'(0) = 1$;

3) $y''' - y' = 0$, $y(0) = 3$, $y'(0) = -1$, $y''(0) = 1$;

4) $y''' - 5y'' + 8y' - 4y = 0$, $y(0) = 1$, $y'(0) = 1$, $y''(0) = 2$.

3.4. CHIZIQLI BIR JINSLI BO‘LMAGAN DIFFERENSIAL TENGLAMALAR

Ikkinchi tartibli chiziqli bir jinsli bo‘lmagan differensial tenglamalar.

Ixtiyoriy o‘zgarmasni variatsiyalash usuli. Ikkinchi tartibli chiziqli bir jinsli bo‘lmagan o‘zgarmas koeffitsiyentli differensial tenglamalar. Yuqori tartibli chiziqli bir jinsli bo‘lmagan differensial tenglamalar

3.4.1. Ushbu

$$y'' + p(x)y' + q(x)y = f(x) \tag{4.1}$$

ko‘rinishdagi tenglamaga *ikkinchi tartibli chiziqli bir jinsli bo‘lmagan differensial tenglama* deyiladi, bu yerda $p(x)$, $q(x)$, $f(x) \neq 0$ – erkli o‘zgaruvchi x ning uzluksiz funksiyalari.

Chap tomoni (4.1) tenglamaning chap tomoni bilan bir xil bo‘lgan

$$y'' + p(x)y' + q(x)y = 0 \tag{4.2}$$

tenglamaga (4.1) ga mos bir jinsli tenglama deyiladi.

Agar (4.2) tenglamaning $y_1(x)$ va $y_2(x)$ xususiy yechimlari $[a;b]$ kesmada fundamental sistema tashkil qilsa, tenglamaning umumiy yechimi

$$y(x) = C_1 y_1(x) + C_2 y_2(x)$$

ko‘rinishda bo‘ladi, bu yerda C_1, C_2 – ixtiyoriy o‘zgarmaslar.

1-teorema. (4.1) tenglamaning $Y(x)$ umumiy yechimi bu tenglamaning birorta $\bar{y}(x)$ xususiy yechimi bilan mos bir jinsli (4.2) tenglama $y(x)$ umumiy yechimining yig‘indisiga teng bo‘ladi, ya’ni

$$Y(x) = \bar{y}(x) + y(x).$$

3.4.2. Ixtiyoriy o‘zgarmasni variatsiyalash usulida (4.1) tenglamaning xususiy yechimi (4.2) tenglamaning fundamental sistema tashkil qiluvchi y_1 va y_2 xususiy yechimlarining chiziqli kombinatsiyasi shaklida, ya’ni

$$\bar{y} = C_1(x)y_1 + C_2(x)y_2$$

ko‘rinishda izlanadi. $C_1(x)$ va $C_2(x)$ noma’lum funksiyalarni topish uchun avval

$$\begin{cases} C_1'(x)y_1 + C_2'(x)y_2 = 0, \\ C_1'(x)y_1' + C_2'(x)y_2' = f(x) \end{cases}$$

sistema tuziladi va bu sistemadan $C_1'(x)$ va $C_2'(x)$ hosilalar aniqlanadi. Keyin $C_1'(x)$ va $C_2'(x)$ hosilalar integrallanadi, bunda integrallash o‘zgarmaslari nolga teng deb olinadi.

1-misol. $y_1 = e^x$ va $y_2 = x$ lar $y'' - \frac{x}{x-1}y' + \frac{1}{x-1}y = 0$ tenglamaning fundamental yechimlari sistemasini tashkil qilishini ko‘rsating va $(x-1)y'' - xy' + y = (x-1)^2$ differensial tenglamaning umumiy yechimini toping.

☉ $y_1 = e^x$ va $y_2 = x$ funksiyalarni berilgan tenglamaga qo‘yamiz:

$$y_1 = e^x \text{ da } (e^x)'' - \frac{x}{x-1}(e^x)' + \frac{1}{x-1}e^x = e^x \left(1 - \frac{x}{x-1} + \frac{1}{x-1} \right) = 0;$$

$$y_2 = x \text{ da } (x)'' - \frac{x}{x-1}(x)' + \frac{1}{x-1}x = -\frac{x}{x-1} + \frac{x}{x-1} = 0.$$

Demak, $y_1 = e^x$ va $y_2 = x$ lar $y'' - \frac{x}{x-1}y' + \frac{1}{x-1}y = 0$ tenglamaning xususiy yechimlari bo‘ladi.

Berilgan tenglamada $p(x) = -\frac{x}{x-1}$, $q(x) = \frac{1}{x-1}$. Demak, $y_1 = e^x$ va $y_2 = x$

yechimlarning yagonalik sohasi $D = \{(x, y) : x \neq 1\}$. D sohada $\frac{y_2}{y_1} = \frac{x}{e^x} \neq const$.

Shunday qilib, $y_1 = e^x$ va $y_2 = x$ yechimlar fundamental sistema tashkil qiladi va $y'' - \frac{x}{x-1}y' + \frac{1}{x-1}y = 0$ tenglamaning umumiy yechimi $y = C_1e^x + C_2x$ bo'ladi.

$(x-1)y'' - xy' + y = (x-1)^2$ tenglamaning chap va o'ng tomonini $(x-1)$ ga bo'lamiz:

$$y'' - \frac{x}{x-1}y' + \frac{1}{x-1}y = x-1.$$

Bu tenglamada $f(x) = x-1$. Mos bir jinsli tenglamaning umumiy yechimi $y = C_1e^x + C_2x$. Ixtiyoriy o'zgarmasni variatsiyalash usuliga ko'ra berilgan tenglamaning xususiy yechimini

$$\bar{y} = C_1(x)e^x + C_2(x)x$$

ko'rinishda izlaymiz. Bu yerda $C_1(x)$ va $C_2(x)$ funksiyalar

$$\begin{cases} C_1'(x)e^x + C_2'(x)x = 0, \\ C_1'(x)e^x + C_2'(x) = x-1 \end{cases}$$

sistemadan topiladi.

Sistemaning yechimi: $C_1'(x) = xe^{-x}$, $C_2'(x) = -1$.

Bu hosilalarni integrallaymiz:

$$C_1(x) = -(x+1)e^{-x} + \bar{C}_1, \quad C_2(x) = -x + \bar{C}_2.$$

$\bar{C}_1 = \bar{C}_2 = 0$ deymiz va $C_1(x)$ va $C_2(x)$ ni $\bar{y} = C_1(x)e^x + C_2(x)x$ tenglamaga qo'yamiz:

$$\bar{y} = -x^2 - x - 1.$$

Demak, berilgan tenglamaning umumiy yechimi

$$Y = C_1e^x + C_2^*x - x^2 - 1, \quad (C_2^* = C_2 - 1). \quad \blacktriangleleft$$

2-teorema. Agar (4.1) tenglamaning o'ng tomoni ikki funksiyaning yig'indisidan iborat, ya'ni

$$y'' + p(x)y' + q(x)y = f_1(x) + f_2(x) \quad (4.3)$$

va $\bar{y}_1(x), \bar{y}_2(x)$ o'ng tomoni mos ravishda $f_1(x), f_2(x)$ bo'lgan (4.1) tenglamaning yechimlari bo'lsa, u holda

$$\bar{y}(x) = \bar{y}_1(x) + \bar{y}_2(x)$$

yig'indi (4.3) tenglamaning yechimi bo'ladi.

2-misol. $y'' + 5y' + 6y = e^{-x} + e^{-2x}$ differensial tenglamaning umumiy yechimini toping.

☞ Berilgan tenglamaga mos xarakteristik tenglama $k_1 = -2$ va $k_2 = -3$ ildizlarga ega. Demak, berilgan tenglamaga mos bir jinsli tenglamaning umumiy yechimi:

$$y = C_1 e^{-2x} + C_2 e^{-3x}.$$

Tenglamaning o'ng tomoni ikkita $f_1(x) = e^{-x}$ va $f_2(x) = e^{-2x}$ funksiyalarning yig'indisidan iborat. Shu sababli ikkita

$$y'' + 5y' + 6y = e^{-x} \quad \text{va} \quad y'' + 5y' + 6y = e^{-2x}$$

tenglamani yechamiz.

Birinchi tenglamaning xususiy yechimini $\bar{y}_1 = C_1(x)e^{-2x} + C_2(x)e^{-3x}$ ko'rinishda izlaymiz.

Bu yerda $C_1(x)$ va $C_2(x)$ funksiyalar

$$\begin{cases} C_1'(x)e^{-2x} + C_2'(x)e^{-3x} = 0, \\ -2C_1'(x)e^{-2x} - 3C_2'(x)e^{-3x} = e^{-x} \end{cases}$$

sistemadan topiladi.

Sistemani yechamiz: $C_1'(x) = e^x$, $C_2'(x) = -e^{2x}$.

Hosilalarni integrallaymiz:

$$C_1(x) = e^x, \quad C_2(x) = -\frac{1}{2}e^{2x},$$

$C_1(x)$ va $C_2(x)$ ni \bar{y}_1 ga qo'yib, birinchi tenglamaning xususiy yechimini topamiz:

$$\bar{y}_1 = e^x e^{-2x} - \frac{1}{2}e^{2x} e^{-3x} = \frac{1}{2}e^{-x}.$$

Ikkinchi tenglamaning xususiy yechimini $\bar{y}_2 = C_3(x)e^{-2x} + C_4(x)e^{-3x}$ ko'rinishda izlaymiz.

$$\begin{cases} C_3'(x)e^{-2x} + C_4'(x)e^{-3x} = 0, \\ -2C_3'(x)e^{-2x} - 3C_4'(x)e^{-3x} = e^{-2x} \end{cases}$$

sistemadan $C_3'(x) = 1$, $C_4'(x) = -e^x$ yoki $C_3(x) = x$, $C_4(x) = -e^x$ kelib chiqadi.

Bundan

$$\bar{y}_2 = (x-1)e^{-2x}.$$

Berilgan tenglamaning umumiy yechimini $Y = y + \bar{y}_1 + \bar{y}_2$ tenglik bilan topamiz:

$$Y = C_1^* e^{-2x} + C_2 e^{-3x} + \frac{1}{2}e^{-x} + xe^{-2x}, \quad C_1^* = C_1 - 1. \quad \text{☞}$$

3.4.3. (4.1) tenglamaning xususiy holi bo'lgan

$$y'' + py' + qy = f(x) \quad (4.4)$$

tenglamaga *ikkinchi tartibli chiziqli bir jinsli bo'lmagan o'zgarmas koeffitsiyentli* differensial tenglama deyiladi bu yerda p, q – o'zgarmas haqiqiy sonlar, $f(x) \neq 0$ – erkli o'zgaruvchi x ning uzluksiz funksiyasi.

(4.4) tenglamani ixtiyoriy o'zgarmasni variatsiyalash usuli bilan yechish mumkin.

Agar (4.4) tenglamaning o'ng tomoni «maxsus ko'rinish» deb ataluvchi

$$I. f(x) = e^{\alpha x} \cdot P_n(x) \quad \text{yoki} \quad II. f(x) = e^{\alpha x} \cdot (P_n(x) \cos \beta x + Q_m(x) \sin \beta x)$$

ko'rinishda bo'lsa, bu tenglamani yechishda uning $\bar{y}(x)$ xususiy yechimini topishning ancha oson bo'lgan nom'alum koeffitsiyentlar usulidan foydalanish mumkin.

⇒ *Noma'lum koeffitsiyentlar usulida* avval (4.5) tenglama o'ng tomoni $f(x)$ ning ko'rinishiga mos xususiy yechimning noma'lum koeffitsiyentli izlanayotgan shakli yozib olinadi, keyin u (4.4) tenglamaga qo'yiladi va hosil bo'lgan ayniyatdan noma'lum koeffitsiyentlarning qiymati aniqlanadi.

I hol. (4.4) tenglamaning o'ng tomoni $f(x) = e^{\alpha x} \cdot P_n(x)$ ko'rinishda bo'lsin, bu yerda $P_n(x) - n \geq 0$ darajali ko'phad; $\alpha - k^2 + pk + q = 0$ xarakteristik tenglamaning r karrali ildizi.

Bu holda (4.4) tenglamaning xususiy yechimi

$$\bar{y} = e^{\alpha x} \cdot x^r \cdot Q_n(x) \quad (4.5)$$

ko'rinishda izlanadi, bu yerda $Q_n(x)$ – koeffitsiyentlari noma'lum bo'lgan n – darajali ko'phad.

II hol. (4.4) tenglamaning o'ng tomoni $f(x) = e^{\alpha x} \cdot (P_n(x) \cos \beta x + Q_m(x) \sin \beta x)$ ko'rinishda bo'lsin, bu yerda $P_n(x), Q_m(x) - n, m$ – darajali ko'phadlar; $\alpha \pm i\beta - k^2 + pk + q = 0$ xarakteristik tenglamaning r karrali ildizi.

Bu holda (4.4) tenglamaning xususiy yechimi

$$\bar{y} = e^{\alpha x} \cdot x^r \cdot (M_l(x) \cos \beta x + N_l(x) \sin \beta x) \quad (4.6)$$

ko'rinishda izlanadi, bu yerda $M_l(x), N_l(x)$ – koeffitsiyentlari noma'lum bo'lgan l – darajali ko'phadlar, $l = \max(m, n)$.

(4.4) tenglamaning xarakteristik tenglamasi kvadrat tenglama bo'lgani uchun *I holda* r soni 0, 1, 2 qiymatlarni, *II holda* 0, 1 qiymatlarni qabul qilishi mumkin. Bunda r soni 0 qiymatni α yoki $\alpha \pm i\beta$ xarakteristik tenglamaning yechimi bo'lmaganda qabul qiladi.

Izohlar: 1. (4.6) ifodani (4.4) tenglamaga qo‘ygandan keyin tenglamaning chap va o‘ng tomonidagi bir nomdagi trigonometrik funksiyalar oldidagi ko‘phadlar tenglashtiriladi.

2. (4.6) shakl $P_n(x) \equiv 0$ yoki $Q_m(x) \equiv 0$ bo‘lganda ham saqlanadi.

3. Agar (4.4) tenglamaning o‘ng tomoni I yoki II shakllarning yig‘indisidan iborat bo‘lsa, xususiy yechim ham mos shakllarning yig‘indisi ko‘rinishida izlanadi.

3-misol. $y^{iv} - y''' + y'' - y' = f_i(x)$ differensial tenglamaning umumiy yechimini toping, bu yerda 1) $f_1(x) = 5 - 2x$; 2) $f_2(x) = 4e^x$;

3) $f_3(x) = (4x - 6)e^{-x}$; 4) $f_4(x) = 2 \cos x + 6 \sin x$;

5) $f_5(x) = \cos 2x - 3 \sin 2x$; 6) $f_6(x) = 5e^x(\cos x + \sin x)$.

⊕ Berilgan tenglamaga mos xarakteristik tenglama $k_1 = 0$, $k_2 = 1$, $k_3 = i$, $k_4 = -i$ ildizlarga ega. Demak, berilgan tenglamaga mos bir jinsli tenglamaning umumiy yechimi:

$$y = C_1 + C_2 e^x + C_3 \cos x + C_4 \sin x.$$

U holda berilgan tenglamaning umumiy yechimi

$$Y_i = C_1 + C_2 e^x + C_3 \cos x + C_4 \sin x + \bar{y}_i$$

bo‘ladi, \bar{y}_i – berilgan tenglamaning $f_i(x)$ funksiyaga mos xususiy yechimi.

Har bir $f_i(x)$ uchun tenglamaning \bar{y}_i xususiy yechimini noma’lum koeffitsiyentlar usuli bilan topamiz.

1) $f_1(x) = 5 - 2x$ funksiya uchun $\alpha = 0$, $n = 1$. $\alpha = 0$ xarakteristik tenglamaning bir karrali ildizi bo‘lgani uchun $r = 1$. Birinchi darajali noma’lum koeffitsiyentli ko‘phadning umumiy ko‘rinishi $Q_1(x) = Ax + B$.

Bu holda xususiy yechimni

$$\bar{y}_1 = e^{0x} x^1 (Ax + B) = Ax^2 + Bx$$

ko‘rinishda izlaymiz.

$\bar{y}_1' = 2Ax + B$, $\bar{y}_1'' = 2A$, $\bar{y}_1''' = \bar{y}_1^{iv} = 0$ hosilalarni berilgan tenglamaga qo‘yamiz:

$$2A - 2Ax - B = 5 - 2x.$$

x ning bir xil darajalari oldidagi koeffitsiyentlarni tenglaymiz:

$$\begin{cases} -2A = -2, \\ 2A - B = 5. \end{cases}$$

Bundan $A = 1$, $B = -3$.

Demak, tenglamaning xususiy yechimi

$$\bar{y}_1 = x^2 - 3x$$

va umumiy yechimi

$$Y_1 = C_1 + C_2 e^x + C_3 \cos x + C_4 \sin x + x^2 - 3x.$$

2) $f_2(x) = 4e^x$ funksiya uchun $\alpha = 1$, $n = 0$. U holda $r = 1$, $Q_0(x) = A$.

Bundan

$$\bar{y}_2 = e^{1x} x^1 A = A x e^x.$$

$$\bar{y}_2' = A(x+1)e^x, \quad \bar{y}_2'' = A(x+2)e^x, \quad \bar{y}_2''' = A(x+3)e^x, \quad \bar{y}_2^{IV} = A(x+4)e^x$$

hosilalarni berilgan tenglamaga qo'yib, topamiz: $2A = 4$ yoki $A = 2$.

Demak, tenglamaning xususiy yechimi

$$\bar{y}_2 = 2x e^x$$

va umumiy yechimi

$$Y_2 = C_1 + C_2 e^x + C_3 \cos x + C_4 \sin x + 2x e^x.$$

3) $f_3(x) = (4x - 6)e^{-x}$ funksiya uchun $\alpha = -1$, $n = 1$.

Bu holda $r = 0$, $Q_1(x) = Ax + B$ va $\bar{y}_3 = e^{-1x} x^0 (Ax + B) = (Ax + B)e^{-x}$ bo'ladi.

$$\bar{y}_3' = (-Ax - B + A)e^{-x}, \quad \bar{y}_3'' = (Ax + B - 2A)e^{-x},$$

$$\bar{y}_3''' = (-Ax - B + 3A)e^{-x}, \quad \bar{y}_3^{IV} = (Ax + B - 4A)e^{-x}$$

hosilalarni berilgan tenglamaga qo'yamiz va x ning bir xil darajalari oldidagi koeffitsiyentlarni tenglab, topamiz: $A = 1$, $B = 1$.

Bundan

$$\bar{y}_3 = (x + 1)e^{-x},$$

$$Y_3 = C_1 + C_2 e^x + C_3 \cos x + C_4 \sin x + (x + 1)e^{-x}.$$

4) $f_4(x) = 2 \cos x + 6 \sin x$ funksiya uchun $\alpha = 0$, $\beta = 1$, $n = 0$, $\alpha \pm \beta i = \pm i$.

Bunda $r = 1$, $M_0(x) = A$, $N_0 = B$.

U holda $\bar{y}_3 = e^{0x} x^1 (A \cos x + B \sin x) = x(A \cos x + B \sin x)$.

$$\bar{y}_4' = (A + Bx) \cos x + (B - Ax) \sin x, \quad \bar{y}_4'' = -(2A + Bx) \sin x + (2B - Ax) \cos x,$$

$$\bar{y}_4''' = -(3A + Bx) \cos x - (3B - Ax) \sin x, \quad \bar{y}_4^{IV} = (4A + Bx) \sin x - (4B - Ax) \cos x$$

hosilalarni berilgan tenglamaga qo'yamiz va $\cos x$, $\sin x$ funksiyalar oldidagi koeffitsiyentlarni tenglab, topamiz: $A = 2$, $B = 1$.

Bundan

$$\bar{y}_4 = x(2 \cos x + \sin x),$$

$$Y_4 = C_1 + C_2 e^x + C_3 \cos x + C_4 \sin x + x(2 \cos x + \sin x).$$

5) $f_5(x) = \cos 2x - 3 \sin 2x$ funksiya uchun $\alpha = 0$, $\beta = 2$, $n = 0$, $\alpha \pm \beta i = \pm 2i$.

Bunda $r = 0$, $M_0(x) = A$, $N_0 = B$.

U holda $\bar{y}_3 = e^{0x} x^0 (A \cos 2x + B \sin 2x) = A \cos 2x + B \sin 2x$.

$$\bar{y}'_3 = -2A \sin 2x + 2B \cos 2x, \quad \bar{y}''_3 = -4A \cos 2x - 4B \sin 2x,$$

$$\bar{y}'''_3 = 8A \sin 2x - 8B \cos 2x, \quad \bar{y}^{IV}_3 = 16A \cos 2x - 16B \sin 2x$$

hosilalarni berilgan tenglamaga qo'yamiz va $\cos 2x$, $\sin 2x$ funksiyalar oldidagi koeffitsiyentlarni tenglab, topamiz: $A = \frac{1}{6}$, $B = -\frac{1}{6}$.

Demak,

$$\bar{y}_3 = \frac{1}{6}(\cos 2x - \sin 2x),$$

$$Y_5 = C_1 + C_2 e^x + C_3 \cos x + C_4 \sin x + \frac{1}{6}(\cos 2x - \sin 2x).$$

6) $f_6(x) = 5e^x(\cos x + \sin x)$ funksiya uchun $\alpha = 1$, $\beta = 1$, $n = 0$, $\alpha \pm \beta i = 1 \pm i$.

Bunda $r = 0$, $M_0(x) = A$, $N_0 = B$.

U holda $\bar{y}_3 = e^{1x} x^0 (A \cos x + B \sin x) = e^x (A \cos x + B \sin x)$.

$$\bar{y}'_6 = e^x ((A + B) \cos x + (B - A) \sin x), \quad \bar{y}''_6 = e^x (2B \cos x - 2A \sin x),$$

$$\bar{y}'''_6 = e^x (2(B - A) \cos x - 2(B + A) \sin x), \quad \bar{y}^{IV}_6 = e^x (-4A \cos x - 4B \sin x)$$

hosilalarni berilgan tenglamaga qo'yamiz va $\cos x$, $\sin x$ funksiyalar oldidagi koeffitsiyentlarni tenglab, topamiz: $A = -1$, $B = -2$.

Demak,

$$\bar{y}_3 = -e^x (\cos x + 2 \sin x),$$

$$Y_6 = C_1 + C_2 e^x + C_3 \cos x + C_4 \sin x - e^x (\cos x + 2 \sin x). \quad \bullet$$

⇒ Agar (4.4) tenglama o'ng tomonining ko'rinishi *I* yoki *II* shaklga to'liq mos kelmasa, u holda $\bar{y}(x)$ xususiy yechimni

$$\bar{y} = e^{k_1 x} \left(\int e^{(k_2 - k_1)x} \left(\int f(x) e^{-k_2 x} dx \right) dx \right) \quad (4.7)$$

formula bilan topish mumkin, bu yerda k_1, k_2 - xarakteristik tenglamaning ildizlari.

Bunda k_1 va k_2 kompleks-qo'shma yechim bo'lgan holda trigonometrik funksiyalarni Eyler formulasidan kelib chiqadigan

$$\cos \alpha = \frac{1}{2}(e^{i\alpha} + e^{-i\alpha}), \quad \sin \alpha = \frac{1}{2i}(e^{i\alpha} - e^{-i\alpha}) \quad (4.8)$$

formulalar orqali ko'rsatkichli funksiyalarga o'tkazish qulay bo'ladi.

4-misol. $y'' + 4y' + 4y = e^{-2x} \ln x$ differensial tenglamaning umumiy yechimini toping.

☞ Berilgan tenglamaga mos xarakteristik tenglama $k_1 = k_2 = -2$ ildizga ega. Demak, berilgan tenglamaga mos bir jinsli tenglamaning umumiy yechimi:

$$y = (C_1 + C_2 x)e^{-2x}.$$

$f(x) = e^{-2x} \ln x$ funksiyaning ko‘rinishi *I* yoki *II* shaklga to‘liq mos kelmaydi. Shu sababli bu tenglamaning xususiy yechimni

$$\bar{y} = e^{k_1 x} \left(\int e^{(k_2 - k_1)x} \left(\int f(x) e^{-k_2 x} dx \right) dx \right)$$

formula bilan topamiz:

$$\bar{y} = e^{-2x} \left(\int e^{(-2+2)x} \left(\int e^{-2x} \ln x e^{-2x} dx \right) dx \right) = e^{-2x} \left(\int \left(\int \ln x dx \right) dx \right) =$$

$$= e^{-2x} \int (x \ln x - x) dx = e^{-2x} \left(\frac{1}{2} x^2 \ln x - \frac{1}{4} x^2 - \frac{1}{2} x^2 \right) = e^{-2x} \left(\frac{1}{2} x^2 \ln x - \frac{3}{2} x^2 \right).$$

Demak, tenglamaning umumiy yechimi

$$Y = \left(C_1 + C_2 x + \frac{1}{2} x^2 \ln x - \frac{3}{2} x^2 \right) \cdot e^{-2x}. \quad \ominus$$

3.4.4. Ikkinchi tartibli chiziqli bir jinsli bo‘lmagan differensial tenglama uchun olingan natijalarni

$$y^{(n)} + a_1(x)y^{(n-1)} + \dots + a_{n-1}(x)y' + a_n(x)y = f(x) \quad (4.9)$$

ko‘rinishdagi $n - (n > 2)$ tartibli chiziqli bir jinsli differensial bo‘lmagan differensial tenglama uchun tatbiq etish mumkin.

Xususan:

1. Bu tenglamaga mos bir jinsli tenglama

$$y^{(n)} + a_1(x)y^{(n-1)} + \dots + a_{n-1}(x)y' + a_n(x)y = 0 \quad (4.10)$$

ko‘rinishda bo‘ladi.

2. Bir jinsli bo‘lmagan (4.9) tenglamaning umumiy yechimi $Y = \bar{y} + y$ formula bilan aniqlanadi, bu yerda $y - (4.10)$ tenglamaning umumiy yechimi, \bar{y} – berilgan (4.9) tenglamaning yechimlaridan biri.

3. (4.9) tenglamani yechishning umumiy usuli ixtiyoriy o‘zgarmaslarni variatsiyalash usulidan iborat. Bu usulda (4.10) tenglamaning y_1, y_2, \dots, y_n fundamental yechimlar sistemasi ma’lum bo‘lsa (4.9) tenglamaning xususiy yechimi quyidagi ko‘rinishda izlanadi:

$$\bar{y} = C_1(x)y_1 + C_2(x)y_2 + \dots + C(x)y_n, \quad (47.11)$$

bu yerda $C_1(x), C_2(x), \dots, C_n(x)$ funksiyalar quyidagi sistemadan topiladi:

$$\begin{cases} C_1'(x)y_1 + C_2'(x)y_2 + \dots + C_n'(x)y_n = 0, \\ C_1'(x)y_1' + C_2'(x)y_2' + \dots + C_n'(x)y_n' = 0, \\ \dots \dots \dots \dots \dots \dots \dots \dots \dots \dots \\ C_1'(x)y_1^{(n-2)} + C_2'(x)y_2^{(n-2)} + \dots + C_n'(x)y_n^{(n-2)} = 0, \\ C_1'(x)y_1^{(n-1)} + C_2'(x)y_2^{(n-1)} + \dots + C_n'(x)y_n^{(n-1)} = f(x) \end{cases} \quad (47.12)$$

4. n – tartibli chiziqli bir jinsli bo‘lmagan o‘zgarmas koeffitsiyentli differensial tenglamaning xususiy yechimi ixtiyoriy o‘zgarmasni variatsiyalash usuli bilan topiladi. Bunda tenglamaning o‘ng tomoni maxsus ko‘rinishda bo‘lsa, uning xususiy yechimi noma’lum koeffitsiyentlar usuli bilan topilishi mumkin.

5. Agar $f(x)$ funksiyaning ko‘rinishi I yoki II shaklga to‘liq mos kelmasa, u holda $\bar{y}(x)$ xususiy yechimni

$$\bar{y} = e^{k_1 x} (\int e^{(k_2 - k_1)x} (\int e^{(k_3 - k_2)x} \dots (\int e^{(k_n - k_{n-1})x} (\int f(x) e^{-k_2 x} dx) dx \dots) dx) dx) \quad (4.13)$$

formula bilan topish mumkin, bu yerda k_1, k_2, \dots, k_n – xarakteristik tenglamaning ildizlari.

Mashqlar

3.4.1. $y_1 = x^2$ va $y_2 = x$ funksiyalar $y'' - \frac{2}{x}y' + \frac{2}{x^2}y = 0$ tenglamaning fundamental yechimlari sistemasini tashkil qilishini ko‘rsating va $x^2 y'' - 2xy' + 2y = x^3 e^x$ differensial tenglamaning umumiy yechimini toping.

3.4.2. $y_1 = x^3$ va $y_2 = x^4$ funksiyalar $y'' - \frac{6}{x}y' + \frac{12}{x^2}y = 0$ tenglamaning fundamental yechimlari sistemasini tashkil qilishini ko‘rsating va $x^2 y'' - 6xy' + 12y = 3x$ differensial tenglamaning umumiy yechimini toping.

3.4.3. $y'' - 2y' + y = e^x + e^{-x}$ tenglamaning umumiy yechimini toping.

3.4.4 $y'' + y' = e^x + x^2$ tenglamaning umumiy yechimini toping.

3.4.5. Differensial tenglamalarni ixtiyoriy o‘zgarmasni variatsiyalash usuli bilan yeching:

1) $y'' - 2y' + y = \frac{e^x}{x}$;

2) $y'' - y' = e^{2x} \sin e^x$;

$$3) y'' + y = \frac{1}{\sin x};$$

$$4) y'' + y = \frac{1}{\cos^3 x}.$$

3.4.6. $y'' - 3y' + 2y = f_i(x)$ tenglamaning umumiy yechimini toping:

$$1) f_1(x) = 6e^{-x};$$

$$2) f_2(x) = 3e^{2x};$$

$$3) f_3(x) = (3 - 4x)e^x;$$

$$4) f_4(x) = 2e^x \sin x.$$

3.4.7. Differensial tenglama xususiy yechimini yozing:

$$1) y'' + y = 3 + xe^{2x} + x^2 \cos x;$$

$$2) y'' - y = 5 + xe^x + e^x \cos x;$$

$$3) y''' + y' = 4x + x^2 e^x + x \sin x;$$

$$4) y''' - y'' = 2 + xe^x + 2x \cos x.$$

3.4.8. Differensial tenglamaning umumiy yechimini toping:

$$1) y'' + y' = 2x + 3;$$

$$2) y'' - 2y' + y = x + 4;$$

$$3) y'' - 2y' + 2y = x^2;$$

$$4) y'' - 3y' = 9x^2;$$

$$5) y'' + y' = 2e^x;$$

$$6) y'' - y = e^{-x};$$

$$7) y'' - 2y' + y = xe^x;$$

$$8) y'' - 4y' = xe^{4x};$$

$$9) y'' + 2y' + y = \cos x;$$

$$10) y'' - 5y' + 6y = 26 \sin 3x;$$

$$11) y'' + y = x \sin x;$$

$$12) y'' - 2y' = x \cos x;$$

$$13) y'' - 7y' + 6y = e^x \sin x;$$

$$14) y'' - 9y = e^{3x} \cos x;$$

$$15) y'' - 5y' + 6y = e^x + x^2;$$

$$16) y'' + y = xe^x + 2e^{-x};$$

$$17) y''' + y'' = e^{-x};$$

$$18) y''' - 2y'' + y' = xe^x;$$

$$19) y^{IV} - y = e^x;$$

$$20) y^{IV} - y'' = 3x.$$

3.4.9. Differensial tenglamani yeching:

$$1) y'' - 3y' + 2y = \left(\frac{e^x}{e^x + 1} \right)^2;$$

$$2) y'' - 2y' + y = \frac{e^x}{\sqrt{4 - x^2}}.$$

3.5. DIFFERENSIAL TENGLAMALAR SISTEMALARI

**Normal sistemalarni integrallash usullari. O'zgarmas koeffitsiyentli
chiziqli differensial tenglamalar sistemalari**

3.5.1. Tenglamalari noma'lum funksiyalarining yuqori tartibli hosilasiga nisbatan yechilgan differensial tenglamalar sistemalariga *kanonik sistemalar* deyiladi.

m noma'lumli m ta differensial tenglamalarning kanonik sistemasi umumiy ko'rinishda

$$y_i^{(k_i)} = f_i(x, y_1, y_1', \dots, y_1^{(k_1-1)}, \dots, y_m, y_m', \dots, y_m^{(k_m-1)}), \quad i = \overline{1, m} \quad (5.1)$$

kabi yoziladi, bu yerda x – erkli o'zgaruvchi, $y_1(x), y_2(x), \dots, y_m(x)$ – noma'lum funksiyalar.

Noma'lum funksiyalarning hosilalariga nisbatan yechilgan

$$y_i' = f_i(x, y_1, y_2, \dots, y_n), \quad i = \overline{1, n} \quad (5.2)$$

birinchi tartibli differensial tenglamalar sistemasiga *normal sistema* deyiladi.

⇒ Agar (5.1) sistemada $y_i', y_i'', \dots, y_i^{(k_i-1)}$ hosilalarni yangi yordamchi noma'lum funksiyalar deb olinsa, (5.1) kanonik sistemani bu sistemaga ekvivalent bo'lgan va $n = k_1 + k_2 + \dots + k_m$ ta tenglamalardan tashkil topgan (5.2) normal sistema bilan almashtirish mumkin bo'ladi.

1 – misol. Differensial tenglamalar yoki sistemalarni differensial tenglamalarning normal sistemasiga keltiring (x – erkli o'zgaruvchi):

$$1) \quad y'' + ky = 0; \quad 2) \quad y''' - 2xyy' + y'^2 = 0;$$

$$3) \quad \begin{cases} 3y_1' - y_2' + 2y_1 = \cos x, \\ y_1' + y_2 = \sin x \end{cases}, \quad 4) \quad \begin{cases} y_1'' + y_2' + y_1 = \ln x, \\ y_1' + y_2'' = 3 \end{cases}$$

☞ 1) $y' = y_1$ deymiz. Bundan $y'' = y_1'$ bo'ladi.

U holda berilgan tenglamani

$$\begin{cases} y' = y_1, \\ y_1' = -ky \end{cases}$$

ko'rinishda yozish mumkin.

2) Qo'shimcha funksiyalar kiritamiz:

$$y' = y_1, \quad y'' = y_1' = y_2.$$

U holda berilgan tenglama $y_2' = 2xyy_1 - y_1^2$ kabi yoziladi.

Natijada

$$\begin{cases} y' = y_1, \\ y_1' = y_2, \\ y_2' = 2xyy_1 - y_1^2 \end{cases}$$

normal sistema kelib chiqadi.

3) Ikkinchi tenglamadan topamiz:

$$y_1' = -y_2 + \sin x.$$

Bu ifodani birinchi tenglamaga qo'yamiz va uni y_2' nisbatan yechamiz:

$$y_2' = 3\sin x - \cos x + 2y_1 - 3y_2.$$

Demak,

$$\begin{cases} y_1' = \sin x - y_2, \\ y_2' = 3 \sin x - \cos x + 2y_1 - 3y_2. \end{cases}$$

4) Qo'shimcha $y_3 = y_1'$, $y_4 = y_2'$ funksiyalar kiritamiz va berilgan sistemani

$$\begin{cases} y_3' + y_4 + y_1 = \ln x, \\ y_3 + y_4' = 3 \end{cases}$$

ko'rinishga keltiramiz.

Bundan

$$\begin{cases} y_1' = y_3, \\ y_2' = y_4, \\ y_3' = \ln x - y_4 - y_1, \\ y_4' = 3 - y_3. \end{cases}$$

normal sistema hosil bo'ladi. 

(5.2) *normal sistemaning yechimi* deb bu sistemaning har bir tenglamasini qanoatlantiradigan $y_1(x), y_2(x), \dots, y_n(x)$ funksiyalar to'plamiga aytiladi.

(5.2) sistemaning $y_1(x_0)| = y_1^0, y_2(x_0)| = y_2^0, \dots, y_n(x_0)| = y_n^0$ boshlang'ich shartlarni qanoatlantiruvchi xususiy yechimini topish masalasiga *Koshi masalasi* deyiladi.

Yo'qotish usuli

Normal sistemani yechishning asosiy usullaridan biri sistemani bitta yuqori tartibli differensial tenglamaga keltirish va keyin yechish hisoblanadi. Bu usulda normal sistemaning noma'lum funksiyalaridan birini differensiallashtirish orqali uning bitta noma'lumidan boshqa barcha noma'lumlari ketma-ket yo'qotiladi. Bu usul noma'lumlarni yo'qotish usuli deb ataladi.

Normal sistemani *yo'qotish usuli* bilan yechish quyidagi tartibda amalga oshiriladi:

1°. (5.2) sistemaning istalgan, masalan, birinchi tenglamasi x bo'yicha differensiallanadi

$$y_1'' = \frac{\partial f_1}{\partial x} + \frac{\partial f_1}{\partial y_1} y_1' + \frac{\partial f_1}{\partial y_2} y_2' + \dots + \frac{\partial f_1}{\partial y_n} y_n'.$$

va o'ng tomondagi y_i' hosilalar o'rniga f_i ifodalarni qo'yib, y_1'' topiladi:

$$y_1'' = F_2(x, y_1, y_2, \dots, y_n);$$

2°. Bu jarayon davom ettiriladi va quyidagi sistema hosil qilinadi:

$$\begin{cases} y_1' = f_1(x, y_1, y_2, \dots, y_n), \\ y_1'' = F_2(x, y_1, y_2, \dots, y_n), \\ \dots \dots \dots \dots \dots \\ y_1^{(n)} = F_n(x, y_1, y_2, \dots, y_n); \end{cases} \quad (5.3)$$

3°. (5.3) sistemaning birinchi $(n-1)$ ta tenglamasidan $(n-1)$ ta y_2, y_3, \dots, y_n funksiyalar $x, y_1, y_1', y_1'', \dots, y_1^{(n-1)}$ o'zgaruvchilar orqali ifodalanadi va

$$\begin{cases} y_2 = \psi_2(x, y_1, y_1', \dots, y_1^{(n-1)}), \\ y_3 = \psi_3(x, y_1, y_1', \dots, y_1^{(n-1)}), \\ \dots \dots \dots \dots \dots \\ y_n = \psi_n(x, y_1, y_1', \dots, y_1^{(n-1)}) \end{cases} \quad (5.4)$$

sistema hosil qilinadi;

4°. y_2, y_3, \dots, y_n larning bu ifodalari (5.3) sistemaning oxirgi tenglamasiga qo'yiladi va y_1 funksiyaning n -tartibli differensial tenglamasini hosil qilinadi:

$$y_1^{(n)} = \Phi(x, y_1, y_1', \dots, y_1^{(n-1)}).$$

5°. Bu tenglama yechiladi va $y_1 = \varphi_1(x, C_1, C_2, \dots, C_n)$ yechim topiladi;

6°. y_1 yechim $(n-1)$ marta differensiallanadi, $y_1', y_1'', \dots, y_1^{(n-1)}$ lar (5.4) sistema tenglamalariga qo'yiladi va (5.2) sistemaning qolgan yechimlari topiladi:

$$y_2 = \varphi_2(x, C_1, C_2, \dots, C_n), \dots, y_n = \varphi_n(x, C_1, C_2, \dots, C_n).$$

2 – misol. Normal sistemalarni yo'qotish usuli bilan yeching:

$$1) \begin{cases} y_1' + 3y_1 + y_2 = 0, \\ y_2' - y_1 + y_2 = 0 \end{cases}; \quad 2) \begin{cases} y_1' = y_1 + y_2 - \cos x, \\ y_2' = -2y_1 - y_2 + \sin x + \cos x \end{cases}$$

☞ 1) Sistemaning birinchi tenglamasini differensiallaymiz:

$$y_1'' + 3y_1' + y_2' = 0.$$

Berilgan sistemaning tenglamalari yordamida oxirgi tenglikdan y_2' va y_2 larni yo'qotamiz:

$$y_1'' + 4y_1' + 4y_1 = 0.$$

Hosil bo'lgan o'zgaruvchisiz ko'rsatkichli chiziqli bir jinsli differensial tenglamani yechamiz:

$$y_1 = (C_1 + C_2 x)e^{-2x}.$$

Bundan

$$y_1' = (C_2 - 2C_1 - 2C_2 x)e^{-2x}.$$

y_1 va y_1' larni sistemaning birinchi tenglamasiga qo'yib, topamiz:

$$y_2 = -(C_1 + C_2(x+1))e^{-2x}.$$

Demak, berilgan sistemaning umumiy yechimi:

$$\begin{cases} y_1 = (C_1 + C_2x)e^{-2x}, \\ y_2 = -(C_1 + C_2(x+1))e^{-2x}. \end{cases}$$

2) Sistemaning birinchi tenglamasini differensiallaymiz:

$$y_1'' = y_1' + y_2' + \sin x.$$

Bu tenglikka y_2' ning sistema ikkinchi tenglamasidagi ifodasini qo'yamiz:

$$y_1'' = y_1' - 2y_1 - y_2 + 2\sin x + \cos x.$$

Sistemaning birinchi tenglamasidan y_1 ni topamiz va oxirgi tenglamaga qo'yamiz:

$$y_1'' + y_1 = 2\sin x.$$

Hosil bo'lgan ikkinchi tartibli o'zgarmas koeffitsiyentli bir jinsli bo'lmagan tenglama bir jinsli qismining yechimi:

$$y_1 = C_1 \cos x + C_2 \sin x.$$

Uning xususiy yechimini $\bar{y}_1 = x(A \cos x + B \sin x)$ ko'rinishda izlaymiz.

Bundan

$$\bar{y}_1' = (A + Bx) \cos x + (B - Ax) \sin x, \quad \bar{y}_1'' = (2B - Ax) \cos x - (2A + Bx) \sin x.$$

\bar{y}_1' va \bar{y}_1'' ni $y_1'' + y_1 = 2\sin x$ tenglamaga qo'yib topamiz:

$$A = -1, \quad B = 0, \quad Y_1 = -x \cos x.$$

Bundan

$$y_1 = C_1 \cos x + C_2 \sin x - x \cos x,$$

$$y_1' = -C_1 \sin x + C_2 \cos x - \cos x + x \sin x.$$

Sistemaning birinchi tenglamasidan topamiz:

$$y_2 = y_1' - y_1 + \cos x.$$

Bu ifodaga y_1 va y_1' larning ifodalarini qo'yamiz:

$$y_2 = (C_2 - C_1) \cos x - (C_1 + C_2) \sin x + x(\cos x + \sin x).$$

Shunday qilib, berilgan sistemaning umumiy yechimi:

$$\begin{cases} y_1 = C_1 \cos x + C_2 \sin x - x \cos x, \\ y_2 = (C_2 - C_1) \cos x - (C_1 + C_2) \sin x + x(\cos x + \sin x). \end{cases} \quad \odot$$

3-misol. Koshi masalasini yeching:

$$\begin{cases} y_1' = y_2, \\ y_2' = y_1, \\ y_3' = y_1 + y_2 + y_3, \end{cases} \quad y_1(0) = 3, \quad y_2(0) = 1, \quad y_3(0) = -1.$$

⊗ Sistemaning birinchi tenglamasidan topamiz:

$$y_1'' = y_2'$$

yoki ikkinchi tenglamadan

$$y_1'' - y_1 = 0$$

kelib chiqdi.

Bundan

$$y_1 = C_1 e^x + C_2 e^{-x}, \quad y_2 = C_1 e^x - C_2 e^{-x}.$$

y_1 va y_2 larning bu qiymatlarini uchinchi tenglamaga qo'yamiz:

$$y_3' - y_3 = 2C_1 e^x.$$

Bu tenglamani yechamiz:

$$y_3 = 2C_1 x e^x + C_3 e^x.$$

Ixtiyoriy o'zgarmlarni boshlang'ich shartlardan topamiz:

$$C_1 + C_2 = 3, \quad C_1 - C_2 = 1, \quad C_3 = -1.$$

Bundan $C_1 = 2$, $C_2 = 1$, $C_3 = -1$.

Demak, berilgan sistemaning xususiy yechimi

$$\begin{cases} y_1 = 2e^x + e^{-x}, \\ y_2 = 2e^x - e^{-x}, \\ y_3 = (4x - 1)e^x. \end{cases} \quad \odot$$

Integrallanuvchi kombinatsiyalar usuli

Normal sistemani yechishning *integrallanuvchi kombinatsiyalar* usulida arifmetik amallar yordamida berilgan sistemaning tenglamalaridan yangi noma'lum funksiyaga nisbatan oson integrallanuvchi differensial tenglamalar hosil qilinadi.

(5.2) normal sistema berilgan bo'lsin. Bitta integrallanuvchi kombinatsiya erkli o'zgaruvchi x va y_1, y_2, \dots, y_n noma'lum funksiyalarni bog'lovchi bitta $\Phi_1(x, y_1, y_2, \dots, y_n) = C_1$ tenglamani beradi. Chekli sondagi bunday tenglamalarga (5.2) sistemaning birinchi integrallari deyiladi.

(5.2) normal sistemaning n ta $\Phi_1, \Phi_2, \dots, \Phi_n$ birinchi integrallari topilgan bo'lsa va bu funksiyalar bog'liq bo'lmasa, ya'ni $\Phi_1, \Phi_2, \dots, \Phi_n$ funksiyalar sistemasining yakobiani nolga teng bo'lmasa, (5.2) sistemaning barcha

$y_1(x), y_2(x), \dots, y_n(x)$ noma'lum funksiyalari

$$\begin{cases} \Phi_1(x, y_1, y_2, \dots, y_n) = C_1, \\ \Phi_2(x, y_1, y_2, \dots, y_n) = C_2, \\ \dots \dots \dots \dots \dots \\ \Phi_n(x, y_1, y_2, \dots, y_n) = C_n \end{cases}$$

sistemadan topiladi.

4-misol. Normal sistemalarni integrallanuvchi kombinatsiyalar usuli bilan yeching:

$$1) \begin{cases} y_1' = y_2 + 1, \\ y_2' = y_1 + 1 \end{cases}, \quad 2) \begin{cases} y_1' = y_1^2 + y_1 y_2, \\ y_2' = y_1 y_2 + y_2^2 \end{cases}.$$

☉ 1) Sistemaning birinchi tenglamasiga ikkinchi tenglamasini hadma-had qo'shamiz:

$$y_1' + y_2' = y_1 + y_2 + 2.$$

Bundan

$$\frac{d(y_1 + y_2 + 2)}{y_1 + y_2 + 2} = dx \quad \text{yoki} \quad y_1 + y_2 = C_1 e^x - 2.$$

Sistemaning birinchi tenglamasidan ikkinchi tenglamasini hadma-had ayiramiz va hosil bo'lgan tenglikni integrallaymiz:

$$y_1 - y_2 = C_2 e^{-x}.$$

Topilgan birinchi integrallardan

$$\begin{cases} y_1 = \frac{1}{2}(C_1 e^x + C_2 e^{-x}) - 1, \\ y_2 = \frac{1}{2}(C_1 e^x - C_2 e^{-x}) - 1 \end{cases}$$

kelib chiqadi.

2) Sistemaning birinchi va ikkinchi tenglamalarini qo'shamiz:

$$y_1' + y_2' = y_1^2 + 2y_1 y_2 + y_2^2.$$

Bundan

$$\frac{d(y_1 + y_2)}{(y_1 + y_2)^2} = dx \quad \text{yoki} \quad -\frac{1}{y_1 + y_2} = x + C_1.$$

Sistemaning birinchi tenglamasini ikkinchi tenglamasiga bo'lamiz va hosil bo'lgan tenglikni integrallaymiz:

$$\frac{dy_1}{dy_2} = \frac{y_1}{y_2} \quad \text{yoki} \quad y_1 = C_2 y_2.$$

Birinchi integrallardan avval y_2 va keyin y_1 ni yo‘qotib, topamiz:

$$\begin{cases} y_1 = -\frac{C_2}{(C_2 + 1)(x + C_1)}, \\ y_2 = -\frac{1}{(C_2 + 1)(x + C_1)}. \end{cases} \quad \ominus$$

\Rightarrow (5.2) normal sistemada integrallanuvchi ko‘paytuvchilar ajratish uchun sistemani simmetrik forma deb ataluvchi

$$\frac{dx}{1} = \frac{dy_1}{f_1(x, y_1, \dots, y_n)} = \frac{dy_2}{f_2(x, y_1, \dots, y_n)} = \dots = \frac{dy_n}{f_n(x, y_1, \dots, y_n)}$$

ko‘rinishda yozib olish va keyin teng kasrlarning quyidagi xossasidan foydalanish mumkin: agar $\frac{u_1}{v_1} = \frac{u_2}{v_2} = \dots = \frac{u_n}{v_n} = \gamma$ bo‘lsa, u holda istalgan

$\alpha_1, \alpha_2, \dots, \alpha_n$ da $\frac{\alpha_1 u_1 + \alpha_2 u_2 + \dots + \alpha_n u_n}{\alpha_1 v_1 + \alpha_2 v_2 + \dots + \alpha_n v_n} = \gamma$ bo‘ladi.

Bunda $\alpha_1, \alpha_2, \dots, \alpha_n$ lar shunday tanlanadiki, oxirgi tenglikning yoki surati maxrajining to‘liq differensial bo‘ladi yoki maxraji nolga teng bo‘ladi.

5-misol. $\begin{cases} y_1' = \frac{2(y_2 + x)}{y_2 - 2y_1}, \\ y_2' = -\frac{x + 2y_1}{y_2 - 2y_1} \end{cases}$ differensial tenglamalar sistemasini yeching.

\ominus Sistemani simmetrik ko‘rinishda yozib olamiz:

$$\frac{dx}{y_2 - 2y_1} = \frac{dy_1}{2y_2 + 2x} = \frac{dy_2}{-x - 2y_1} = \gamma.$$

Integrallanuvchi kombinatsiyalardan birinчисini topamiz:

$$\frac{2dx - dy_1 - 2dy_2}{0} = \gamma \quad \text{yoki} \quad d(2x - y_1 - 2y_2) = 0.$$

Bundan

$$2x - y_1 - 2y_2 = C_1.$$

Integrallanuvchi kombinatsiyalardan ikkinчисini topamiz:

$$\frac{2xdx + 2y_1 dy_1 + 2y_2 dy_2}{0} = \gamma \quad \text{yoki} \quad d(x^2 + y_1^2 + y_2^2) = 0.$$

Bundan

$$x^2 + y_1^2 + y_2^2 = C_2.$$

$2x - y_1 - 2y_2 = C_1$ va $x^2 + y_1^2 + y_2^2 = C_2$ birinchi integrallar berilgan sistemaning umumiy yechimini oshkormas aniqlaydi. \ominus

3.5.2. Normal sistemalarning xususiylaridan biri ushbu

$$y'_i = a_{i1}y_1 + a_{i2}y_2 + \dots + a_{in}y_n + f_i(x), \quad i = \overline{1, n} \quad (5.8)$$

o'zgaras koeffitsiyentli chiziqli differensial tenglamalar sistemasi hisoblanadi, bu yerda a_{ij} – berilgan o'zgaras koeffitsiyentlar.

$f_i(x) \equiv 0$ bo'lsa (5.8) sistemaga *bir jinsli sistema* deyiladi. Bir jinsli sistema $y_i(x) \equiv 0$ trivial yechimlarga ega bo'ladi.

(5.8) sistemaga mos bir jinsli

$$\begin{cases} y'_1 = a_{11}y_1 + a_{12}y_2 + \dots + a_{1n}y_n, \\ y'_2 = a_{21}y_1 + a_{22}y_2 + \dots + a_{2n}y_n, \\ \dots \dots \dots \dots \dots \\ y'_n = a_{n1}y_1 + a_{n2}y_2 + \dots + a_{nn}y_n \end{cases} \quad (5.9)$$

sistema berilgan bo'lsin. Bu sistema yechimlarini topishning *Eyler usulida* sistemaning xususiylar yechimi $y_1 = \alpha_1 e^{\lambda x}$, $y_2 = \alpha_2 e^{\lambda x}$, ..., $y_n = \alpha_n e^{\lambda x}$ funksiyalar ko'rinishda izlanadi, bu yerda α_i ($i = \overline{1, n}$), λ – o'zgaraslar.

α_i ($i = \overline{1, n}$) va λ ning qiymatlarini topish uchun avval $y_i = \alpha_i e^{\lambda x}$, $y'_i = \lambda \alpha_i e^{\lambda x}$ (5.9) tenglamalar sistemasiga qo'yiladi va $\alpha_1, \alpha_2, \dots, \alpha_n$ larga nisbatan

$$\begin{cases} (a_{11} - \lambda)\alpha_1 + a_{12}\alpha_2 + \dots + a_{1n}\alpha_n = 0, \\ a_{21}\alpha_1 + (a_{22} - \lambda)\alpha_2 + \dots + a_{2n}\alpha_n = 0, \\ \dots \dots \dots \dots \dots \\ a_{n1}\alpha_1 + a_{n2}\alpha_2 + \dots + (a_{nn} - \lambda)\alpha_n = 0 \end{cases} \quad (5.10)$$

algebraik tenglamalar sistemasi hosil qilinadi.

Keyin (5.10) *sistemaning xarakteristik tenglamasi* deb ataluvchi

$$\begin{vmatrix} a_{11} - \lambda & a_{12} & \dots & a_{1n} \\ a_{21} & a_{22} - \lambda & \dots & a_{2n} \\ \dots & \dots & \dots & \dots \\ a_{n1} & a_{n2} & \dots & a_{nn} \end{vmatrix} = 0. \quad (5.11)$$

tenglamadan A matritsaning xos sonlari $\lambda_1, \lambda_2, \dots, \lambda_n$ topiladi.

(5.11) xarakteristik tenglamaning barcha yechimlari haqiqiy va har xil bo'lsa

(5.9) differensial tenglamalar sistemasi quyidagi yechimlarga ega bo'ladi:

$$\begin{cases} y_1 = C_1 \alpha_{11} e^{\lambda_1 x} + C_2 \alpha_{12} e^{\lambda_2 x} + \dots + C_n \alpha_{1n} e^{\lambda_n x}, \\ y_2 = C_1 \alpha_{21} e^{\lambda_1 x} + C_2 \alpha_{22} e^{\lambda_2 x} + \dots + C_n \alpha_{2n} e^{\lambda_n x}, \\ \dots \dots \dots \dots \dots \\ y_n = C_1 \alpha_{n1} e^{\lambda_1 x} + C_2 \alpha_{n2} e^{\lambda_2 x} + \dots + C_n \alpha_{nn} e^{\lambda_n x}. \end{cases}$$

Agar (5.12) karakteristik tenglamaning ildizlari orasida kompleks yoki karrali ildizlar bo'lsa, u holda bu ildizlarga mos xususiy yechimlar n -tartibli chiziqli o'zgarmas koeffitsiyentli bir jinsli differensial tenglamalarda topilgandagi kabi topiladi.

6-misol. Differensial tenglamalarning umumiy yechimini toping:

$$1) \begin{cases} y_1' = 2y_1 + y_2, \\ y_2' = 3y_1 + 4y_2, \end{cases} \quad 2) \begin{cases} y_1' = 5y_1 - y_2, \\ y_2' = y_1 + 3y_2, \end{cases} \quad 3) \begin{cases} y_1' = y_2 - 7y_1, \\ y_2' = -2y_1 - 5y_2. \end{cases}$$

☞ 1) Sistemaning karakteristik tenglamasini tuzamiz:

$$\begin{vmatrix} 2 - \lambda & 1 \\ 3 & 4 - \lambda \end{vmatrix} = 0$$

yoki $\lambda^2 - 6\lambda + 5 = 0$. Bundan $\lambda_1 = 1$, $\lambda_2 = 5$.

Sistema matritsasining xos vektorlarini topish uchun

$$\begin{cases} (2 - \lambda)\alpha_1 + \alpha_2 = 0, \\ 3\alpha_1 + (4 - \lambda)\alpha_2 = 0 \end{cases}$$

sistemani tuzamiz. Bu sistemadan $\lambda_1 = 1$ da topamiz:

$$\alpha_{11} + \alpha_{21} = 0, \quad 3\alpha_{11} + 3\alpha_{21} = 0.$$

Bu tenglamalardan biri ikkinchisidan kelib chiqadi. Shu sababli tenglamalardan birini olib qolamiz. Bundan $\alpha_{21} = -\alpha_{11}$ yoki $\alpha_{11} = 1$ desak, $\alpha_{21} = -1$ kelib chiqadi.

Yuqoridagi sistemadan $\lambda_2 = 5$ da shu kabi topamiz: $\alpha_{22} = 1$, $\alpha_{12} = 3$.

Demak, berilgan sistemaning yechimi

$$\begin{cases} y_1 = C_1 e^x + C_2 e^{5x}, \\ y_2 = -C_1 e^x + 3C_2 e^{5x}. \end{cases}$$

2) Sistemaning karakteristik tenglamasi

$$\begin{vmatrix} 5 - \lambda & -1 \\ 1 & 3 - \lambda \end{vmatrix} = 0, \quad \lambda^2 - 8\lambda + 16 = 0.$$

Bundan

$$\lambda_1 = \lambda_2 = 4.$$

Bu ildizlarga

$$y_1 = e^{4x}(C_1 x + C_2), \quad y_2 = e^{4x}(C_3 x + C_4)$$

yechimlar mos keladi.

y_1 va y_2 larni differensiallaymiz:

$$y_1' = e^{4x}(C_1 + 4C_1 x + 4C_2), \quad y_2' = e^{4x}(C_3 + 4C_3 x + 4C_4).$$

y_1, y_2, y_1' va y_2' larni berilgan sistemaga qo'yamiz:

$$\begin{cases} C_1 + 4C_1x + 4C_2 \equiv 5C_1x + 5C_2 - C_3x - C_4, \\ C_3 + 4C_3x + 4C_4 \equiv C_1x + C_2 + 3C_3x + 3C_4. \end{cases}$$

Ayniyatlarning chap va o'ng tomonlarida x ning bir xil darajalari oldidagi koeffitsiyentlarni tenglashtiramiz:

$$\begin{cases} 4C_1 \equiv 5C_1 - C_3, \\ 4C_3 \equiv C_1 + 3C_3, \end{cases} \quad \text{va} \quad \begin{cases} C_1 + 4C_2 \equiv 5C_2 - C_4, \\ C_3 + 4C_4 \equiv C_2 + 3C_4. \end{cases}$$

Birinchi sistemadan $C_3 = C_1$ va ikkinchi sistemadan $C_4 = C_2 - C_1$ kelib chiqadi.

Demak, sistemaning umumiy yechimi $\begin{cases} y_1 = e^{4x}(C_1x + C_2), \\ y_2 = e^{4x}(C_1x + C_2 - C_1). \end{cases}$

3) Sistemaning xarakteristik tenglamasini tuzamiz va yechamiz:

$$\begin{vmatrix} -7 - \lambda & 1 \\ -2 & -5 - \lambda \end{vmatrix} = 0, \quad \lambda_1 = -6 - i, \quad \lambda_2 = -6 + i.$$

$\lambda_1 = -6 - i$ da

$$\begin{cases} (i-1)\alpha_{11} + \alpha_{21} = 0, \\ -2(i-1)\alpha_{11} - 2\alpha_{21} = 0 \end{cases}$$

sistemadan $\alpha_{21} = (1-i)\alpha_{11}$ yoki $\alpha_{11} = 1$ desak, $\alpha_{21} = 1-i$ kelib chiqadi.

$\lambda_2 = -6 + i$ da shu kabi topamiz: $\alpha_{12} = 1, \alpha_{22} = 1+i$.

U holda berilgan sistemaning yechimi

$$\begin{cases} y_1 = C_1 e^{(-6-i)x} + C_2 e^{(-6+i)x}, \\ y_2 = (1-i)C_1 e^{(-6-i)x} + (1+i)C_2 e^{(-6+i)x} \end{cases}$$

bo'ladi. Bu sistemaga Eyler formulasini qollab, berilgan sistemaning umumiy yechimini topamiz:

$$\begin{cases} y_1 = e^{-6x}((C_1 + C_2)\cos x + i(C_2 - C_1)\sin x), \\ y_2 = e^{-6x}(((C_1 + C_2 + i(-C_1 + C_2))\cos x + (-(C_1 + C_2) + i(-C_1 + C_2))) \end{cases}$$

yoki

$$\begin{cases} y_1 = e^{-6x}(\bar{C}_1 \cos x + \bar{C}_2) \sin x, \\ y_2 = e^{-6x}((\bar{C}_1 + \bar{C}_2)\cos x + (\bar{C}_2 - \bar{C}_1)\sin x) \end{cases}$$

bo'ladi, bu yerda $\bar{C}_1 = C_1 + C_2, \bar{C}_2 = i(C_2 - C_1)$. 

\Rightarrow (5.8) sistemaning xususiy yechimlari ixtiyoriy o'zgarmasni variatsiyalash usuli yoki aniqmas koeffitsiyentlar usuli bilan topiladi.

7-misol. Differensial tenglamalarning umumiy yechimini toping:

$$1) \begin{cases} y_1' + 2y_1 + 4y_2 = 1 + 4x, \\ y_2' + y_1 - y_2 = \frac{3}{2}x^2 \end{cases}; \quad 2) \begin{cases} y_1' - y_1 - 2y_2 = 0, \\ y_2' - y_1 = -5\sin x \end{cases}.$$

☉ 1) Sistemaning mos bir jinsli tenglamani tuzamiz:

$$\begin{cases} y_1' + 2y_1 + 4y_2 = 0, \\ y_2' + y_1 - y_2 = 0 \end{cases} \quad \text{yoki} \quad \begin{cases} y_1' = -2y_1 - 4y_2, \\ y_2' = -y_1 + y_2. \end{cases}$$

Sistemaning xarakteristik tenglamasini tuzamiz va yechamiz:

$$\begin{vmatrix} -2 - \lambda & -4 \\ -1 & 1 - \lambda \end{vmatrix} = 0, \quad \lambda_1 = -3, \quad \lambda_2 = 2.$$

$\lambda_1 = -3$ da

$$\begin{cases} \alpha_{11} - 4\alpha_{21} = 0, \\ -\alpha_{11} + 4\alpha_{21} = 0 \end{cases}$$

sistemadan $\alpha_{11} = 4\alpha_{21}$ yoki $\alpha_{21} = 1$ desak, $\alpha_{11} = 4$ kelib chiqadi.

$\lambda_2 = 2$ da shu kabi topamiz: $\alpha_{12} = -1$, $\alpha_{22} = 1$.

U holda berilgan sistemaning yechimi

$$\begin{cases} y_1 = 4C_1e^{-3x} - C_2e^{2x}, \\ y_2 = C_1e^{-3x} + C_2e^{2x}. \end{cases}$$

bo'ladi.

Berilgan sistemaning yechimini ixtiyoriy o'zgarmasni variatsiyalash usuli bilan topamiz:

$$\begin{cases} y_1 = 4C_1(x)e^{-3x} - C_2(x)e^{2x}, \\ y_2 = C_1(x)e^{-3x} + C_2(x)e^{2x}. \end{cases}$$

$\bar{y}_1, \bar{y}_2, \bar{y}_1', \bar{y}_2'$ larni berilgan sistemaga qo'yamiz va almashtirishlar bajaramiz:

$$\begin{cases} 4C_1'(x)e^{-3x} - C_2'(x)e^{2x} = 1 + 4x, \\ C_1'(x)e^{-3x} + C_2'(x)e^{2x} = \frac{3}{2}x^2. \end{cases}$$

Bundan

$$C_1'(x) = \frac{1}{10}(3x^2 + 8x + 2)e^{3x}, \quad C_2'(x) = \frac{1}{5}(6x^2 - 4x - 1)e^{-2x}.$$

Bu ifodalarni integrallaymiz:

$$C_1(x) = \frac{1}{10}(x^2 + 2x)e^{3x} + \bar{C}_1, \quad C_2(x) = -\frac{1}{5}(3x^2 + x)e^{-2x} + \bar{C}_2.$$

Demak, berilgan sistemaning umumiy yechimi

$$\begin{cases} y_1 = 4C_1 e^{-3x} - C_2 e^{2x} + x^2 + x, \\ y_2 = C_1 e^{-3x} + C_2 e^{2x} - \frac{1}{2} x^2. \end{cases}$$

2) Sistemaning mos bir jinsli sistemani yechamiz:

$$\begin{cases} y_1' = y_1 + 2y_2, \\ y_2' = y_1 - 5\sin x \end{cases}$$

$$\begin{vmatrix} 1 - \lambda & 2 \\ 1 & 0 - \lambda \end{vmatrix} = 0, \quad \lambda_1 = -1, \quad \lambda_2 = 2.$$

$\lambda_1 = -1$ da

$$\begin{cases} 2\alpha_{11} + 2\alpha_{21} = 0, \\ \alpha_{11} + \alpha_{21} = 0 \end{cases}$$

sistemadan $\alpha_{11} = -\alpha_{21}$ yoki $\alpha_{11} = 1$ desak, $\alpha_{21} = -1$ kelib chiqadi.

$\lambda_2 = 2$ da shu kabi topamiz: $\alpha_{12} = 2$, $\alpha_{22} = 1$.

U holda berilgan sistemaning yechimi

$$\begin{cases} y_1 = C_1 e^{-x} + 2C_2 e^{2x}, \\ y_2 = -C_1 e^{-x} + C_2 e^{2x} \end{cases}$$

bo'ladi.

Berilgan sistemaning xususiy yechimini

$$\begin{cases} \bar{y}_1 = A_1 \cos x + B_1 \sin x, \\ \bar{y}_2 = A_2 \cos x + B_2 \sin x \end{cases}$$

ko'rinishda izlaymiz.

\bar{y}_1 , \bar{y}_2 , \bar{y}_1' va \bar{y}_2' larni berilgan sistemaga qo'yamiz:

$$\begin{cases} -A_1 \sin x + B_1 \cos x \equiv A_1 \cos x + B_1 \sin x + 2A_2 \cos x + 2B_2 \sin x, \\ -A_2 \sin x + B_2 \cos x \equiv A_1 \cos x + B_1 \sin x - 5 \sin x. \end{cases}$$

Ayniyatlarning chap va o'ng tomonlarida $\cos x$ va $\sin x$ lar oldidagi koeffitsiyentlarni tenglashtiramiz:

$$\begin{cases} -A_1 \equiv B_1 + 2B_2, \\ B_1 \equiv A_1 + 2A_2, \end{cases} \quad \text{va} \quad \begin{cases} -A_2 \equiv B_1 - 5, \\ B_2 \equiv A_1. \end{cases}$$

Sistemalarni yechamiz: $A_1 = -1$, $B_1 = 3$, $A_2 = 2$, $B_2 = -1$.

Demak, sistemaning umumiy yechimi

$$\begin{cases} y_1 = C_1 e^{-x} + 2C_2 e^{2x} - \cos x + 3 \sin x, \\ y_2 = -C_1 e^{-x} + C_2 e^{2x} + 2 \cos x - \sin x. \end{cases} \quad \text{O}$$

Mashqlar

3.5.1. Differensial tenglamalar yoki sistemalarni differensial tenglamalarning normal sistemasiga keltiring (x – erkli o‘zgaruvchi):

$$1) y'' - 2y' + 3y = 0;$$

$$2) y''' - y'' + xy' = y''^2;$$

$$3) \begin{cases} 4y_1' - y_2' + 3y_1 = \sin x, \\ y_1' + y_2 = \cos x + \sin x \end{cases},$$

$$4) \begin{cases} y_2'' + y_2 - 2y_1 = 0, \\ y_1''' + y_2 - y_1 = x \end{cases}.$$

3.5.2. Normal sistemalarni yo‘qotish usuli bilan yeching:

$$1) \begin{cases} y_1' = \frac{y_1}{x}, \\ y_2' = -\frac{x}{y_2} - \frac{y_1^2}{xy_2} \end{cases};$$

$$2) \begin{cases} y_1' = y_2^2 + x, \\ y_2' = \frac{y_1}{2y_2} \end{cases};$$

$$3) \begin{cases} y_1' = \frac{y_1^2}{y_2}, \\ y_2' = y_1 \end{cases};$$

$$4) \begin{cases} y_1' = -\frac{y_2}{x}, \\ y_2' = -\frac{y_1}{x} \end{cases};$$

$$5) \begin{cases} y_1' = \cos x - y_2, \\ y_2' = 4\cos x - \sin x + 3y_1 - 4y_2 \end{cases};$$

$$6) \begin{cases} y_1' + y_1 - y_2 = e^x, \\ y_2' - y_1 + y_2 = e^x \end{cases}.$$

3.5.3. Koshi masalasini yeching:

$$1) \begin{cases} y_1' = y_3 - y_2, \\ y_2' = y_3, \\ y_3' = y_3 - y_1, \quad y_1(0) = 0, \quad y_2(0) = 0, \quad y_3(0) = 2. \end{cases}$$

$$2) \begin{cases} y_1' = y_2 - y_3, \\ y_2' = y_1 + y_2 + x, \\ y_3' = y_1 + y_3 + x, \quad y_1(0) = 0, \quad y_2(0) = 1, \quad y_3(0) = 0. \end{cases}$$

3.5.4. Normal sistemalarni integrallanuvchi kombinatsiyalar usuli bilan yeching:

$$1) \begin{cases} y_1' = y_2, \\ y_2' = y_1 \end{cases},$$

$$2) \begin{cases} y_1' = xy_2, \\ y_2' = xy_1 \end{cases},$$

$$3) \begin{cases} y_1' = \frac{y_1}{2y_2 - y_1}, \\ y_2' = \frac{y_2}{2y_2 - y_1} \end{cases};$$

$$4) \begin{cases} y_1' = \frac{y_2}{(y_2 - y_1)^2}, \\ y_2' = \frac{y_1}{(y_2 - y_1)^2} \end{cases};$$

$$5) \frac{dx}{y_2 - y_1} = \frac{dy_1}{x - y_2} = \frac{dy_2}{y_1 - x};$$

$$6) \frac{dx}{x(x^2 + 3y_1^2)} = \frac{dy_1}{2y_1^3} = \frac{dy_2}{2y_1^2 y_2}.$$

3.5.5. Differensial tenglamalar sistemasining umumiy yechimini toping:

$$1) \begin{cases} y_1' = 3y_1 + y_2, \\ y_2' = 2y_1 + 2y_2, \end{cases}$$

$$2) \begin{cases} y_1' = y_1 + 3y_2, \\ y_2' = -y_1 + 5y_2, \end{cases}$$

$$3) \begin{cases} y_1' = 2y_1 - y_2, \\ y_2' = 4y_1 + 6y_2, \end{cases}$$

$$4) \begin{cases} y_1' = y_1 - 4y_2, \\ y_2' = y_1 - 3y_2, \end{cases}$$

$$5) \begin{cases} y_1' = y_1 - y_2, \\ y_2' = y_1 + y_2, \end{cases}$$

$$6) \begin{cases} y_1' = 2y_1 - y_2, \\ y_2' = y_1 + 2y_2, \end{cases}$$

$$7) \begin{cases} y_1' = y_1 - 2y_2 - y_3, \\ y_2' = -y_1 + y_2 + y_3, \\ y_3' = y_1 - y_3 \end{cases}$$

$$8) \begin{cases} y_1' = -y_1 + y_2 + y_3, \\ y_2' = y_1 - y_2 + y_3, \\ y_3' = y_1 + y_2 + y_3 \end{cases}$$

$$9) \begin{cases} y_1' = y_2 + x, \\ y_2' = y_1 - x, \end{cases}$$

$$10) \begin{cases} y_1' = y_2 + e^x - x, \\ y_2' = -y_2 + e^x + x, \end{cases}$$

$$11) \begin{cases} y_1' = 3y_1 - 2y_2 + x, \\ y_2' = 3y_1 - 4y_2, \end{cases}$$

$$12) \begin{cases} y_1' = -y_2 + x, \\ y_2' = y_1 + e^x. \end{cases}$$

NAZORAT ISHI

- 1.- 2. Differensial tenglamaning umumiy yechimini toping.
3. Differensial tenglamalar sistemasini Eyler usuli bilan yeching.

1-variant

1. a) $y'' - y = 0$, b) $4y'' + 8y' - 5y = 0$, c) $y'' - 6y' + 10y = 0$.

2. $y''' - y'' = 6x + 5$.

3. $\begin{cases} y_1' = y_1 + 2y_2, \\ y_2' = 3y_1 + 6y_2. \end{cases}$

2-variant

1. a) $y'' + 5y = 0$, b) $9y'' - 6y' + y = 0$, c) $y'' + 6y' + 8y = 0$.

2. $y''' - 5y'' + 6y' = 6x^2 + 2x - 5$.

3. $\begin{cases} y_1' = y_1, \\ y_2' = y_2. \end{cases}$

3-variant

1. a) $y'' - 16y = 0$, b) $y'' + 4y' + 20y = 0$, c) $y'' - 3y' - 10y = 0$.

2. $3y^{IV} + y''' = 6x - 1$.

3.
$$\begin{cases} y'_1 = 4y_1 + 2y_2, \\ y'_2 = 4y_1 + 6y_2. \end{cases}$$

4-variant

1. a) $y'' + 4y = 0$, b) $y'' - 10y' + 25y = 0$, c) $y'' + 3y' + 2y = 0$.

2. $y''' + y'' = 6x^2 - 1$.

3.
$$\begin{cases} y'_1 = 2y_1 + y_2, \\ y'_2 = 3y_1 + 4y_2. \end{cases}$$

5-variant

1. a) $y'' - 2y = 0$, b) $y'' - 6y' + 9y = 0$, c) $y'' + 12y' + 37y = 0$.

2. $y''' + 3y'' + 2y' = x^2 + 2x + 3$.

3.
$$\begin{cases} y'_1 = 4y_1 - y_2, \\ y'_2 = -y_1 + 4y_2. \end{cases}$$

6-variant

1. a) $y'' + 9y = 0$, b) $y'' - y' - 2y = 0$, c) $y'' + 4y' + 4y = 0$.

2. $y^{IV} - 3y''' + 3y'' - y' = x - 3$.

3.
$$\begin{cases} y'_1 = -y_1 - 2y_2, \\ y'_2 = 3y_1 + 4y_2. \end{cases}$$

7-variant

1. a) $y'' - 4y' = 0$, b) $y'' - 4y' + 13y = 0$, c) $y'' - 3y' + 2y = 0$.

2. $y''' - 13y'' + 12y' = 1 - x$.

3.
$$\begin{cases} y'_1 = 8y_1 - 3y_2, \\ y'_2 = 2y_1 + y_2. \end{cases}$$

8-variant

1. a) $y'' + 3y' = 0$, b) $y'' - 5y' + 6y = 0$, c) $y'' + 2y' + 5y = 0$.

2. $y^{IV} + 2y''' + y'' = 4x^2$.

3.
$$\begin{cases} y'_1 = 4y_1 - 8y_2, \\ y'_2 = -8y_1 + 4y_2. \end{cases}$$

9-variant

1. a) $y'' - 2y' = 0$, b) $y'' - 2y' + 10y = 0$, c) $y'' + y' - 2y = 0$.

2. $y^{IV} - 6y''' + 9y'' = 2x - 3$.

3.
$$\begin{cases} y'_1 = 2y_1 + 8y_2, \\ y'_2 = y_1 + 4y_2. \end{cases}$$

10-variant

1. a) $y'' - 4y = 0$, b) $y'' + 2y' + 17y = 0$, c) $y'' - y' - 12y = 0$.
2. $y''' - y'' = 6x^2 + 3x$.
3. $\begin{cases} y_1' = y_1 - y_2, \\ y_2' = -4y_1 + y_2. \end{cases}$

11-variant

1. a) $y'' + 9y = 0$, b) $y'' + y' - 6y = 0$, c) $y'' - 4y' + 20y = 0$.
2. $7y''' - y'' = 12x$.
3. $\begin{cases} y_1' = 5y_1 + 4y_2, \\ y_2' = 4y_1 + 5y_2. \end{cases}$

12-variant

1. a) $y'' - 49y = 0$, b) $y'' - 4y' + 5y = 0$, c) $y'' + 2y' - 3y = 0$.
2. $y^{IV} + y''' = 12x + 6$.
3. $\begin{cases} y_1' = y_1 + 4y_2, \\ y_2' = 2y_1 + 3y_2. \end{cases}$

13-variant

1. a) $y'' - 6y' = 0$, b) $y'' + 8y' + 25y = 0$, c) $9y'' + 3y' - 2y = 0$.
2. $y^{IV} - 2y''' + y'' = 12x^2 - 6x$.
3. $\begin{cases} y_1' = -2y_1, \\ y_2' = y_2. \end{cases}$

14-variant

1. a) $y'' + 16y = 0$, b) $6y'' + 7y' - 3 = 0$, c) $4y'' - 4y' + y = 0$.
2. $y''' - 2y'' = 3x^2 + x - 4$.
3. $\begin{cases} y_1' = -y_1 + 8y_2, \\ y_2' = y_1 + y_2. \end{cases}$

15-variant

1. a) $y'' - 3y' = 0$, b) $y'' + 6y' + 10y = 0$, c) $y'' - 5y' + 4y = 0$.
2. $y''' + 3y'' + 2y' = 3x^2 + 2x$.
3. $\begin{cases} y_1' = 6y_1 + 3y_2, \\ y_2' = -8y_1 - 5y_2. \end{cases}$

16-variant

1. a) $y'' + 7y' = 0$, b) $y'' + 4y' + 5y = 0$, c) $y'' - 6y' + 8y = 0$.
2. $y^{IV} + 4y''' + 4y'' = 2 - 3x^2$.
3. $\begin{cases} y_1' = -2y_1 - 3y_2, \\ y_2' = -y_1. \end{cases}$

17-variant

1. a) $y'' + 5y' = 0$, b) $9y'' + 6y' + y = 0$, c) $y'' - 12y' + 37y = 0$.

2. $y^{IV} + 3y''' - 3y'' + y' = 2x$.

3.
$$\begin{cases} y_1' = y_1 + 2y_2, \\ y_2' = 4y_1 + 3y_2. \end{cases}$$

18-variant

1. a) $y'' - 8y' = 0$, b) $4y'' - 8y' + 3y = 0$, c) $y'' + 2y' + 10y = 0$.

2. $y''' - 5y'' = x + x^2$.

3.
$$\begin{cases} y_1' = y_1 - y_2, \\ y_2' = -4y_1 + 4y_2. \end{cases}$$

19-variant

1. a) $y'' + 10y' = 0$, b) $2y'' - 3y' + y = 0$, c) $4y'' + 4y' + y = 0$.

2. $y^{IV} - y''' = 3(x + 2)^2$.

3.
$$\begin{cases} y_1' = 3y_1 - 2y_2, \\ y_2' = 2y_1 + 8y_2. \end{cases}$$

20-variant

1. a) $y'' + y = 0$, b) $y'' + 6y' + 9y = 0$, c) $2y'' + 2y' + 5y = 0$.

2. $y^{IV} + 6y''' + 9y'' = x - x^2$.

3.
$$\begin{cases} y_1' = 3y_1 + y_2, \\ y_2' = y_1 + 3y_2. \end{cases}$$

21-variant

1. a) $y'' + 25y = 0$, b) $2y'' + 3y' + y = 0$, c) $y'' + 4y' + 8y = 0$.

2. $y^V - y^{IV} = 2x + 3$.

3.
$$\begin{cases} y_1' = -2y_1 + y_2, \\ y_2' = -3y_1 + 2y_2. \end{cases}$$

22-variant

1. a) $y'' - 9y = 0$, b) $y'' - 10y' + 21y = 0$, c) $y'' + 2y' + 2y = 0$.

2. $y^{IV} - 4y''' + 4y'' = x^2 + x - 1$.

3.
$$\begin{cases} y_1' = -5y_1 + 2y_2, \\ y_2' = y_1 - 6y_2. \end{cases}$$

23-variant

1. a) $y'' + 49y' = 0$, b) $y'' - 6y' + 13y = 0$, c) $y'' + 8y' + 7y = 0$.

2. $y''' - 4y'' = 2 - 3x + 4x^2$.

3.
$$\begin{cases} y_1' = 6y_1 - y_2, \\ y_2' = 3y_1 + 2y_2. \end{cases}$$

24-variant

1. a) $y'' + 6y' = 0$, b) $y'' - 10y' + 29y = 0$, c) $y'' - 2y' + 2y = 0$.

2. $y''' + 13y'' + 12y' = 18x^2 - 39$.

3.
$$\begin{cases} y_1' = 2y_1 + 3y_2, \\ y_2' = 5y_1 + 4y_2. \end{cases}$$

25-variant

1. a) $y'' - 25y = 0$, b) $y'' - 6y' + 9y = 0$, c) $y'' - 8y' + 25y = 0$.

2. $y''' + 5y'' + 4y' = 1 - x^2$.

3.
$$\begin{cases} y_1' = 5y_1 + 8y_2, \\ y_2' = y_1 + 3y_2. \end{cases}$$

26-variant

1. a) $y'' - 3y' = 0$, b) $y'' - 7y' - 8y = 0$, c) $y'' + 4y' + 13y = 0$.

2. $y^{IV} - 8y''' + 16y'' = 2x(1 - x)$.

3.
$$\begin{cases} y_1' = y_1 + 4y_2, \\ y_2' = y_1 + y_2. \end{cases}$$

27-variant

1. a) $y'' - 81y = 0$, b) $y'' - 10y' + 16y = 0$, c) $2y'' + 5y' + 2y = 0$.

2. $y''' + 3y'' = 4 - 24x^2$.

3.
$$\begin{cases} y_1' = y_1 - 4y_2, \\ y_2' = -y_1 - 3y_2. \end{cases}$$

28-variant

1. a) $y'' - 11y' = 0$, b) $y'' - 3y' - 18y = 0$, c) $3y'' - 2y' - 5y = 0$.

2. $y^{IV} + 4y''' = 2x$.

3.
$$\begin{cases} y_1' = 2y_1 + y_2, \\ y_2' = -6y_1 - 3y_2. \end{cases}$$

29-variant

1. a) $y'' + 81y = 0$, b) $16y'' - 8y' + y = 0$, c) $2y'' + 5y' + 2y = 0$.

2. $y''' - 5y'' + 4y' = (x - 1)^2$.

3.
$$\begin{cases} y_1' = 3y_1 + y_2, \\ y_2' = 8y_1 + y_2. \end{cases}$$

30-variant

1. a) $y'' + 64y = 0$, b) $4y'' + 3y' - y = 0$, c) $y'' + 6y' + 5y = 0$.

2. $y''' - 6y'' = 1 - 2x + 3x^2$.

3.
$$\begin{cases} y_1' = 7y_1 + 3y_2, \\ y_2' = 5y_1 + 5y_2. \end{cases}$$

MUSTAQIL UY ISHI

- 1.-3. Differensial tenglamaning umumiy yechimini toping.
4. Koshi masalasini yeching.
- 5.-6. Differensial tenglamaning umumiy yechimini toping.
7. Differensial tenglamani ixtiyoriy o'zgarmasni variatsiyalash usuli bilan yeching.
8. $f_1(x)$, $f_2(x)$ berilgan. $y'' + 2y' = f_1(x) + f_2(x)$ differensial tenglamaning umumiy yechimini toping.
9. Differensial tenglamalar sistemasining umumiy yechimini toping.

1-variant

1. $(1 + e^{-x})yy' = 1$.
2. $y^2 + x^2 y' = xy y'$.
3. $y' - \frac{y}{x} = x \sin x$.
4. $y'x + y = \frac{xy^2}{3}$, $y(1) = 3$.
5. $(x \cos 2y + 1)dx - x^2 \sin 2y dy = 0$.
6. $y''' = \cos^2 x$.
7. $y'' + y = \operatorname{ctgx}$.
8. $f_1(x) = e^{-2x}(3x + 6)$, $f_2(x) = \cos 2x + 2 \sin 2x$.
9. $\begin{cases} y_1' = 3y_1 - y_2 + e^x, \\ y_2' = y_1 + y_2 + x. \end{cases}$

2-variant

1. $y' \ln y = e^{3x}$.
2. $xy^2 y' = x^3 + y^3$.
3. $y' - \frac{3y}{x} = e^x x^3$.
4. $y' + y = e^{\frac{x}{2}} \sqrt{y}$, $y(0) = \frac{9}{4}$.
5. $e^{-y} dx + (1 - xe^{-y}) dy = 0$.
6. $xy''' = 2$.
7. $y'' + 4y = \operatorname{tg} 2x$.
8. $f_1(x) = e^{-2x}(5x + 4)$, $f_2(x) = \cos x + 4 \sin x$.
9. $\begin{cases} y_1' = 2y_1 - y_2 + \cos x, \\ y_2' = 3y_1 - 2y_2 + \sin x. \end{cases}$

3-variant

1. $\cos^3 yy' - \cos(2x - y) = (\cos 2x + y)$.
2. $(4y + 5x)dx + (5y + 7x)dy = 0$.
3. $y' + 2y = e^{-x^2}$.
4. $y' - y = xy^2$, $y(0) = 1$.
5. $(y + e^x \cos y)dx + (x - e^x \sin y)dy = 0$.
6. $(1 + \sin x)y''' = y'' \cos x$.
7. $y'' + y = x \cos^2 x$.
8. $f_1(x) = 3x^2 + 2$, $f_2(x) = e^{-2x}(\cos x + \sin x)$.
9. $\begin{cases} y_1' = y_1 + y_2 + x, \\ y_2' = y_1 - 2y_2 + 2x. \end{cases}$

4-variant

1. $(e^x + 8)2y - ye^x dx = 0.$

3. $y' - \frac{2y}{x+1} = (x+1)^2.$

5. $ye^x dx + (y + e^x)dy = 0.$

6. $xy'' + y' = \ln x.$

8. $f_1(x) = 6x^2 + 1, f_2(x) = e^{-2x}(2\cos x + \sin x).$

2. $xy' = y\left(\ln \frac{y}{x} - 1\right).$

4. $xy' + y = 2y^2 \ln x, y(1) = \frac{1}{2}.$

7. $y'' + y = \operatorname{tg} x.$

9. $\begin{cases} y_1' = -y_1 + y_2 + x, \\ y_2' = 3y_1 + y_2 + x^2. \end{cases}$

5-variant

1. $3^{x^2+y} dy + x dx = 0.$

3. $y' + \frac{y}{x} = \frac{\ln x + 1}{x}.$

5. $(2x^3 - xy^2)dx + (2y^3 - x^2y)dy = 0.$

6. $y'' \operatorname{tg} x = y' + 1.$

8. $f_1(x) = e^{-2x}(2x - 7), f_2(x) = 2\cos 2x + 3\sin 2x.$

2. $(2\sqrt{xy} - x)y' + y = 0.$

4. $y' + 2y = y^2 e^x, y(0) = \frac{1}{2}.$

7. $y'' + 4y = \operatorname{ctg} 2x.$

9. $\begin{cases} y_1' = y_1 - 3y_2 + e^{2x}, \\ y_2' = y_1 - y_2 + 2x. \end{cases}$

6-variant

1. $e^{-x^2} dy - x(1 + y^2)dx = 0.$

3. $y' - y \operatorname{ctg} x = \sin x.$

5. $\frac{y}{x^2} dx - \frac{xy + 1}{x} dy = 0.$

6. $y''' = x \sin x.$

8. $f_1(x) = e^{-2x}(x^2 + 1), f_2(x) = 3\cos 4x.$

2. $y' = \frac{y}{x} + \sin \frac{y}{x}.$

4. $3xy' + 5y = (4x - 5)y^4, y(1) = 1.$

7. $y'' + 2y' + y = xe^x.$

9. $\begin{cases} y_1' = 2y_1 + y_2 + 1, \\ y_2' = -5y_1 - 2y_2 + x. \end{cases}$

7-variant

1. $e^{3y+x} dx = y dy.$

3. $y' + \frac{2y}{x} = \frac{1}{x^2}.$

5. $(6xy^2 + 4x^3)dx + (6x^2y + y^3)dy = 0.$

6. $y''' \operatorname{tg} 4x = 4y''.$

8. $f_1(x) = 3x^3 - 2x + 1, f_2(x) = 2\cos 4x + 3\sin 4x.$

2. $x^3 y' = y(y^2 + x^2).$

4. $y' + 2xy = 2x^3 y^2, y(0) = \sqrt{2}.$

7. $y'' - 4y' = e^{2x} - e^{-2x}.$

9. $\begin{cases} y_1' = y_1 + 4y_2, \\ y_2' = -y_1 + y_2 + e^{3x}. \end{cases}$

8-variant

1. $x + xy + y'(y + xy) = 0.$

3. $y' + \frac{y}{\cos^2 x} = \frac{\sin x}{\cos^3 x}.$

5. $\left(\frac{y}{x^2 + y^2} + e^x\right)dx - \frac{xdy}{x^2 + y^2} = 0.$

6. $xy''' - 2y'' = \frac{2}{x^2}.$

8. $f_1(x) = 3e^{-2x}, f_2(x) = e^{-2x}(3\cos x + \sin x)$

2. $y' - \frac{y}{x} = \operatorname{tg} \frac{y}{x}.$

4. $y' + y = xy^2, y(0) = 1.$

7. $y'' + 4y = \frac{1}{\sin 2x}.$

9. $\begin{cases} y_1' = 3y_1 + y_2 + e^x, \\ y_2' = y_1 + 3y_2 - e^x. \end{cases}$

9-variant

1. $2yx^2 dy = (1 + x^2) dx.$

3. $y' - \frac{y}{x} = x \cos x.$

5. $\left(\frac{2y}{x^3} + y \cos xy\right) dx + \left(\frac{1}{x^2} + x \cos xy\right) dy = 0.$

6. $xy'' = y' \ln \frac{y'}{x}.$

8. $f_1(x) = 3x^2 + 2x + 1, f_2(x) = e^{-2x}(\cos x + 3\sin x).$

2. $xy' - y = (x + y) + \ln\left(\frac{x + y}{x}\right).$

4. $2(y' + y) = xy^2, y(0) = 2.$

7. $y'' + 5y' + 6y = \frac{1}{1 + e^{2x}}.$

9. $\begin{cases} y_1' = y_2 - \cos x, \\ y_2' = 2y_1 + y_2. \end{cases}$

10-variant

1. $(xy^2 + x) + y'(y - x^2 y) = 0.$

3. $y' + \frac{y}{1 + x^2} = \frac{\operatorname{arctg} x}{1 + x^2}.$

5. $\left(xe^x + \frac{y}{x^2}\right) dx - \frac{1}{x} dy = 0.$

6. $xy''' - y'' = \frac{1}{x}.$

8. $f_1(x) = x^2 + 3x, f_2(x) = 3\cos 2x + \sin 2x.$

2. $xy' = y - xe^{\frac{y}{x}}.$

4. $2(xy' + y) = y^2 \ln x, y(1) = 2.$

7. $y'' - y = \frac{e^x}{e^x + 1}.$

9. $\begin{cases} y_1' = 4y_1 - 5y_2 + 4x + 1, \\ y_2' = y_1 - 2y_2 + x. \end{cases}$

11-variant

1. $xydy = (1 - x^2)dx$.

3. $y' - 2xy = 2x^3$;

5. $\left(\frac{x}{\sqrt{x^2 - y^2}} - 1\right)dx - \frac{y}{\sqrt{x^2 - y^2}}dy = 0$.

6. $xy''' + y'' + x = 0$.

8. $f_1(x) = x^2 + 2$, $f_2(x) = x \cos 2x$.

2. $xy' = y \cos\left(\ln \frac{y}{x}\right)$.

4. $y' - y \operatorname{tg} x = y^4 \cos x$, $y(0) = 1$.

7. $y'' + 2y' + 2y = \frac{e^{-x}}{\cos x}$.

9. $\begin{cases} y_1' = -2y_1 - y_2 + \sin x, \\ y_2' = 4y_1 + 2y_2 + \cos x. \end{cases}$

12-variant

1. $y' + \sqrt{\frac{1 - y^2}{1 - x^2}} = 0$.

3. $x^2 y' + xy + 1 = 0$.

5. $\frac{y}{x^2} dx - \frac{1}{x} dy = 0$.

6. $x^3 y''' + x^2 y'' = \sqrt{x}$.

8. $f_1(x) = e^{-2x}(x + 1)$, $f_2(x) = e^{-2x} x \sin x$.

2. $(x^2 - 2xy)y' = xy - y^2$.

4. $xyy' = y^2 + x$, $y(1) = \sqrt{2}$.

7. $y'' + 4y' + 4y = \frac{e^{-x^3}}{x^3}$.

9. $\begin{cases} y_1' = y_1 - y_2 - e^{-x}, \\ y_2' = -4y_1 + y_2 + xe^{-x}. \end{cases}$

13-variant

1. $\sin y \cos x dy = \cos y \sin x dx$.

3. $y' + \frac{y}{x+1} = x^2$.

5. $\left(x + \frac{y}{x^2 + y^2}\right)dx + \left(y - \frac{x}{x^2 + y^2}\right)dy = 0$.

6. $y''' \operatorname{ctg} 2x + 2y'' = 0$.

8. $f_1(x) = e^{-2x}(3x + 1)$, $f_2(x) = x^2 \sin x$.

2. $y' = \frac{y}{x} + \frac{x}{y}$.

4. $xy' - 2x^2 \sqrt{y} = 4y$, $y(1) = 1$.

7. $y'' + y = \frac{1}{\sin x}$.

9. $\begin{cases} y_1' = 5y_1 + 4y_2 + e^x, \\ y_2' = 4y_1 + 5y_2 + 1. \end{cases}$

14-variant

1. $y' = 10^{x+y}$.
2. $(y + \sqrt{xy}) = xy'$.
3. $y' - \frac{2xy}{1+x^2} = 1 + x^2$.
4. $y' + x\sqrt[3]{y} = 3y, \quad y(0) = 1$.
5. $e^y dx + (\cos y + xe^y) dy = 0$.
6. $y'' = 1 - (y')^2$.
7. $y'' - 2y' + y = \frac{e^x}{x}$.
8. $f_1(x) = e^{-2x}(x-1), \quad f_2(x) = e^{-2x} \sin x$.
9. $\begin{cases} y_1' = -2y_1 - y_2, \\ y_2' = 5y_1 + 2y_2 + x^2 + 1. \end{cases}$

15-variant

1. $\sqrt{1-x^2} dy - x\sqrt{1-y^2} dx = 0$.
2. $y \ln \frac{y}{x} dx - x dy = 0$.
3. $y' + \frac{y}{x} = \frac{\sin x}{x}$.
4. $y' - y \operatorname{tg} x = -\frac{2}{3} y^4 \sin x, \quad y(0) = 1$.
5. $\left(2x - 1 - \frac{y}{x^2}\right) dx - \left(2y - \frac{1}{x}\right) dy = 0$.
6. $yy'' - (y')^2 = y^4$.
7. $y'' - 2y' + y = \frac{e^x}{x^2}$.
8. $f_1(x) = e^x(x+1), \quad f_2(x) = e^x x \sin x$.
9. $\begin{cases} y_1' = 5y_1 - 3y_2 + xe^{2x}, \\ y_2' = 3y_1 - y_2 + e^{2x}. \end{cases}$

16-variant

1. $(1+y)dx = (x-1)dy$.
2. $xyy' = y^2 + 2x^2$.
3. $y' + y \operatorname{tg} x = \cos^2 x$.
4. $y' = \frac{x}{y} e^{2x} + y, \quad y(0) = 2$.
5. $\frac{ydx - xdy}{x^2 + y^2} = 0$.
6. $(y')^2 + 2yy'' = 0$.
7. $y'' + 2y' + y = \frac{1}{xe^x}$.
8. $f_1(x) = e^{-2x}(3x+4), \quad f_2(x) = e^{-2x} x \cos x$.
9. $\begin{cases} y_1' = 4y_1 - y_2, \\ y_2' = y_1 + 2y_2 + xe^x. \end{cases}$

17-variant

1. $\sqrt{4-x^2}y' + xy^2 + x = 0.$
2. $xy + y^2 = (2x^2 + xy)y'.$
3. $(x^2 + 1)y' + 4xy = 3.$
4. $xy' + y = y^2 \ln x, \quad y(1) = 1.$
5. $(y^3 + \cos x)dx + (3xy^2 + e^y)dy = 0.$
6. $y'''x \ln x = y''.$
7. $y'' + 9y = \frac{1}{\sin 3x}.$
8. $f_1(x) = e^x(x^2 + 4), \quad f_2(x) = e^x \sin x.$
9. $\begin{cases} y'_1 = y_1 - 3y_2, \\ y'_2 = y_1 + y_2 + e^x. \end{cases}$

18-variant

1. $x^2 dy - (2xy + 3y)dx = 0.$
2. $(y + 2x)dy - ydx = 0.$
3. $y = x(y' - x \cos x).$
4. $2(xy' + y) = xy^2, \quad y(1) = 1.$
5. $xy^2 dx + y(x^2 + y^2)dy = 0.$
6. $y''x - y' = x^2 e^x.$
7. $y'' - 4y' + 5y = \frac{e^{2x}}{\cos x}.$
8. $f_1(x) = e^x(x^2 - 2), \quad f_2(x) = e^{-2x}x \cos x.$
9. $\begin{cases} y'_1 = y_1 - 3y_2 + 1, \\ y'_2 = -y_1 + y_2 + 2x. \end{cases}$

19-variant

1. $(1 + y^2)dx - \sqrt{x}dy = 0.$
2. $(2y^2 + 3x^2)x dy = (3y^3 + 6yx^2)dx.$
3. $y' + y \tan x = \sin x.$
4. $3(xy' + y) = y^2 \ln x, \quad y(1) = 3.$
5. $(3y^3 \cos 3x + 7)dx + (3y^2 \sin 3x - 2y)dy = 0.$
6. $y''' = e^{2x} + x.$
7. $y'' + 4y = \frac{1}{\cos 2x}.$
8. $f_1(x) = x^3 + 2x - 1, \quad f_2(x) = x(\sin 3x + \cos 3x).$
9. $\begin{cases} y'_1 = 4y_1 + y_2 - e^{3x}, \\ y'_2 = -y_1 + 2y_2. \end{cases}$

20-variant

1. $1 + (1 + y')e^y = 0.$
2. $y^2 = x(x + y)y'.$
3. $xy' - 2y + x^2 = 0.$
4. $yx' + x = -yx^2, \quad x(1) = 2.$
5. $(3x^2 + 2y)dx + (2x - 3)dy = 0.$
6. $y''(3 + 2y) = (2y')^2.$
7. $y'' + 3y' + 2y = \frac{1}{e^x + 1}.$
8. $f_1(x) = x^2 - 4, \quad f_2(x) = e^x(\sin x + \cos x).$
9. $\begin{cases} y'_1 = 2y_1 + y_2 + x, \\ y'_2 = -5y_1 - 2y_2 + x^2. \end{cases}$

21-variant

- $(4x + 2xy^2)dx - (3y - 3x^2y)dy = 0.$
- $(x^2 - 3y^2)dx + 2xydy = 0.$
- $y'\sqrt{1-x^2} + y = \arcsin x.$
- $y' - y + y^2 \cos x = 0, \quad y(0) = 2.$
- $(3x^2y + y^3)dx + (x^3 + 3xy^2)dy = 0.$
- $y''' + y'' \operatorname{tg} x = 0.$
- $y'' + 4y' + 4y = e^{-2x} \ln x.$
- $f_1(x) = e^{-2x}(x+2), \quad f_2(x) = e^{-2x} \sin x.$
- $\begin{cases} y_1' = 2y_1 + y_2 - \cos 3x, \\ y_2' = -y_1 + 4y_2 + \sin 3x. \end{cases}$

22-variant

- $\sin yy' - y \cos x = 2 \cos x.$
- $(y^2 - 2xy)dx - x^2 dy = 0.$
- $y' \sin x - y \cos x = 1.$
- $xy^2 y' = x^2 + y^3, \quad y(1) = \sqrt[3]{3}.$
- $3x^2 e^y dx + (x^3 e^y - 1)dy = 0.$
- $y''(1+y) = (y')^2 + y'.$
- $y'' - 2y = xe^{-x}.$
- $f_1(x) = e^x(2x+6), \quad f_2(x) = e^x(\sin x + 4 \cos x).$
- $\begin{cases} y_1' = 2y_1 - 5y_2, \\ y_2' = y_1 - 2y_2 + e^{2x}. \end{cases}$

23-variant

- $y' = (2y+1) \operatorname{tg} x.$
- $y dx - x dy = \sqrt{x^2 + y^2} dy.$
- $(1-x)(y' + y) = e^{-x}.$
- $xy' - 2\sqrt{x^3} y = y, \quad y(2) = 8.$
- $(3x^2y + \sin x)dx + (x^3 - \cos y)dy = 0.$
- $y''(1+y) = (5y')^2.$
- $y'' - y = e^{2x} \sin(e^x).$
- $f_1(x) = e^{-2x}(3x-2), \quad f_2(x) = 3 \cos 3x.$
- $\begin{cases} y_1' = 2y_1 + 4y_2 + \cos x, \\ y_2' = 3y_1 - 2y_2 + \sin x. \end{cases}$

24-variant

- $\sqrt{3+y^2} dx - y dy = x^2 y dy.$
- $xy' = 4\sqrt{2x^2 + y^2} + y.$
- $x(y' - y) = e^x.$
- $xy' + y = xy^2, \quad y(1) = 1.$
- $(e^{x+y} + 3x^2)dx + (e^{xy} + 4y^3)dy = 0.$
- $(1+x^2)y'' + 1 + (y')^2 = 0.$
- $y'' - y = e^{2x} \cos(e^x).$
- $f_1(x) = e^x(4x-3), \quad f_2(x) = 2 \sin 2x + 3 \cos 2x.$
- $\begin{cases} y_1' = 2y_1 + 3y_2 + e^x, \\ y_2' = y_1 - 2y_2 + 2xe^x. \end{cases}$

25-variant

1. $x(4 + e^y)dx - e^y dy = 0.$

3. $y' + \frac{x}{1-x^2} = \frac{1}{1-x^2}.$

5. $\frac{2x}{y^3}dx + \frac{y^2 - 3x^2}{y^4}dy = 0.$

6. $yy'' - 2yy'\ln y = (y')^2.$

8. $f_1(x) = x^2 + 6x + 4, f_2(x) = e^x x \sin 3x.$

2. $\left(xye^{\frac{x}{y}} + y^2\right) = x^2 e^{\frac{x}{y}} y'.$

4. $y' - y = \frac{x}{y}e^x; \quad y(0) = 4.$

7. $y'' - 4y' + 4y = \frac{e^{2x}}{x^3}.$

9. $\begin{cases} y_1' = -2y_1 - y_2 + e^{-x}, \\ y_2' = 3y_1 + 2y_2 - e^{-x}. \end{cases}$

26-variant

1. $2x + 2xy^2 + \sqrt{1+x^2}y' = 0.$

3. $y' + \frac{y}{x} = \frac{\sin x}{x}.$

5. $\left(\frac{\sin 2x}{y} + x\right)dx + \left(y - \frac{\sin^2 x}{y^2}\right)dy = 0.$

6. $y'''(x-1) - y'' = 0.$

8. $f_1(x) = x^2 - 5x + 1, f_2(x) = e^x x \cos 3x.$

2. $x \ln \frac{x}{y} dy - y dx = 0.$

4. $xdx = \left(\frac{x^2}{y} - y^3\right)dy, \quad x(1) = \sqrt{2}.$

7. $y'' + 2y' = \frac{1}{\cos 3x}.$

9. $\begin{cases} y_1' = y_1 + y_2 - \cos x, \\ y_2' = 3y_1 - y_2 + \sin x + \cos x. \end{cases}$

27-variant

1. $y(1 + \ln y) + xy' = 0.$

3. $y' - \frac{y}{x \ln x} = x \ln x.$

5. $\frac{(x-y)dx + (x+y)dy}{x^2 + y^2} = 0.$

6. $2xy'''y'' = y''^2 - 1.$

8. $f_1(x) = e^x(3x-2), f_2(x) = x^2 \sin 2x.$

2. $3y \sin \frac{3x}{y} + \left(y - 3x \sin \frac{3x}{y}\right)y' = 0.$

4. $y' - xy = -y^3 e^{-x^2}; \quad y(0) = \frac{\sqrt{2}}{2}.$

7. $y'' + y = \frac{2}{\sin^2 x}.$

9. $\begin{cases} y_1' = 4y_1 + y_2 + 36x, \\ y_2' = -2y_1 + y_2 + 2e^x. \end{cases}$

28-variant

1. $y'\sqrt{1-x^2} - \cos^2 y = 0.$
2. $y = x(y' - \sqrt[3]{e^y}).$
3. $y' - \frac{y}{x+2} = x^2 + 2x.$
4. $y'x + y = -xy^2; \quad y(1) = 2.$
5. $\left(\frac{x}{\sqrt{x^2+y^2}} - \frac{y}{x^2}\right)dx + \left(\frac{y}{\sqrt{x^2+y^2}} + \frac{1}{x}\right)dy = 0.$
6. $xy''' + y'' = \frac{1}{\sqrt{x^2}}.$
7. $y'' + \pi^2 y = \frac{\pi^2}{\sin \pi x}.$
8. $f_1(x) = e^{-2x}(5x+4), \quad f_2(x) = x \cos 2x.$
9. $\begin{cases} y_1' = 2y_1 - y_2, \\ y_2' = y_1 + 4y_2 + xe^x. \end{cases}$

29-variant

1. $(1+e^x)ydy - e^y dx = 0.$
2. $(y^2 - x^2)dy = 2xydx.$
3. $y' + y \cos x = \frac{1}{2} \sin 2x.$
4. $xyy' - x = y^2, \quad y(1) = \sqrt{2}.$
5. $\left(\frac{1}{x-y} + 3x^2 y^7\right)dx + \left(7x^3 y^6 - \frac{1}{x-y}\right)dy = 0.$
6. $xy'' - y = 2x^2 e^x.$
7. $y'' + y = \frac{1}{\sin x}.$
8. $f_1(x) = x^2 - 5x + 1, \quad f_2(x) = e^x x \cos 3x.$
9. $\begin{cases} y_1' = -y_2 + \cos x, \\ y_2' = 3y_1 - 4y_2 + 4 \cos x - \sin x. \end{cases}$

30-variant

1. $x\sqrt{4+y^2} dx + y\sqrt{3+x^2} dy = 0.$
2. $(3xy + x^2)y' - 3y^2 = 0.$
3. $xy' + y + xe^{-x^2} = 0.$
4. $y' - y \tan x + y^2 \cos x = 0, \quad y(0) = \frac{1}{2}.$
5. $\frac{2x(1-e^y)}{(1+x^2)^2} dx + \frac{e^y}{1+x^2} dy = 0.$
6. $2xy''y' = (y')^2 - 4.$
7. $y'' + 9y = \frac{1}{\sin 3x}.$
8. $f_1(x) = 6e^x(\cos x + \sin x), \quad f_2(x) = e^{-2x}(5x-2).$
9. $\begin{cases} y_1' = y_1 + y_2 + \sin x, \\ y_2' = 3y_1 - y_2 - \cos x. \end{cases}$

NAMUNAVIY VARIANT YECHIMI

1. Differensial tenglamaning umumiy yechimini toping.

1.30. $x\sqrt{4+y^2}dx + y\sqrt{3+x^2}dy = 0.$

➤ O'zgaruvchilari ajraladigan differensial tenglama berilgan. Uning harikkala tomonini $\sqrt{4+y^2} \cdot \sqrt{3+x^2} \neq 0$ ga bo'lib, o'zgaruvchilarni ajratamiz:

$$\frac{xdx}{\sqrt{3+x^2}} + \frac{ydy}{\sqrt{4+y^2}} = 0.$$

Bu tenglikni integrallaymiz:

$$\sqrt{3+x^2} + \sqrt{4+y^2} = C.$$

Bundan

$$\sqrt{4+y^2} = C - \sqrt{3+x^2}$$

yoki

$$y = \sqrt{(C - \sqrt{3+x^2})^2 - 4}. \quad \ominus$$

2. Differensial tenglamaning umumiy yechimini toping.

2.30. $(3xy + x^2)y' - 3y^2 = 0.$

➤ Berilgan tenglamani

$$y' = \frac{3y^2}{3xy + x^2}$$

ko'rinishga keltiramiz. Bu ifodada

$$f(x, y) = \frac{3y^2}{3xy + x^2}$$

bir jinsli funksiya. Demak, berilgan tenglama bir jinsli tenglama.

Tenglamada $y = ux$, $y' = u'x + x$ o'rniga qo'yish bajaramiz:

$$u'x + u = \frac{3x^2u^2}{3x^2u + x^2} \quad \text{yoki} \quad u'x + u = \frac{3u^2}{3u + 1}.$$

Bundan

$$u'x = \frac{3u^2 - 3u^2 - u}{3u + 1} \quad \text{yoki} \quad u'x = -\frac{u}{3u + 1}.$$

O'zgaruvchilarni ajratamiz:

$$\frac{3u + 1}{u} du = -\frac{dx}{x}.$$

Tenglamani integrallaymiz:

$$\int \frac{3u + 1}{u} du = \ln C - \int \frac{dx}{x} \quad \text{yoki} \quad \ln |u| + 3u = \ln C - \ln |x|.$$

Bundan $3u = \ln \frac{C}{xu}$. $u = \frac{y}{x}$ o'rniga qo'yish bajaramiz:

$$3\frac{y}{x} = \ln \frac{C}{y} \quad \text{yoki} \quad y = Ce^{\frac{-3y}{x}}. \quad \odot$$

3. Differensial tenglamaning umumiy yechimini toping.

3.30. $xy' + y + xe^{-x^2} = 0$.

\odot Tenglamani

$$y' + \frac{y}{x} = -e^{-x^2}$$

ko'rinishiga keltiramiz. Bu tenglama chiziqli tenglama.

Bunda

$$P(x) = \frac{1}{x}, \quad Q(x) = -e^{-x^2}.$$

$y = uv$, $y' = u'v + v'u$ o'rniga qo'yish bajaramiz:

$$u'v + u\left(v' + \frac{v}{x}\right) = -e^{-x^2}$$

Bu tenglamada v funksiyani tanlaymiz va

$$\begin{cases} v' + \frac{v}{x} = 0, \\ u'v = -e^{-x^2} \end{cases}$$

tenglamalar sistemasini hosil qilamiz.

Birinchi tenglamani integrallaymiz:

$$\frac{dv}{v} = -\frac{dx}{x} \quad \text{yoki} \quad \int \frac{dv}{v} = -\int \frac{dx}{x}.$$

Bundan

$$\ln |v| = -\ln |x| + \ln C \quad \text{yoki} \quad C=1 \quad \text{da} \quad v = \frac{1}{x}.$$

v ni sistemaning ikkinchi tenglamasiga qo'yamiz:

$$u' \frac{1}{x} = -e^{-x^2}.$$

U holda

$$u' = -xe^{-x^2} \quad \text{yoki} \quad u = \frac{1}{2}e^{-x^2} + C.$$

Demak, tenglamaning umumiy yechimi

$$y = uv = \frac{e^{-x^2}}{2x} + \frac{C}{x}. \quad \odot$$

4. Koshi masalasini yeching.

4.30. $y' - y \operatorname{tg} x + y^2 \cos x = 0, \quad y(0) = \frac{1}{2}.$

☞ Tenglamani $y' - y \operatorname{tg} x = -y^2 \cos x$ ko‘rinishda yozamiz. Bu tenglama Bernulli tenglamasi. Bunda $n = 2$.

$z = y^{1-2} = y^{-1}$ belgilash kiritamiz va chiziqli

$$z' + z \operatorname{tg} x = \cos x$$

tenglamani hosil qilamiz.

$z = uv, \quad z' = u'v + v'u$ o‘rniga qo‘yish bajaramiz:

$$u'v + u(v' + v \operatorname{tg} x) = \cos x.$$

u, v funksiyalarni topish uchun

$$\begin{cases} v' + v \operatorname{tg} x = 0, \\ u'v = \cos x \end{cases}$$

sistemani tuzamiz.

Sistemaning birinchi tenglamasidan $v = \cos x$ xususiy yechimni topamiz va uni sistemaning ikkinchi tenglamasiga qo‘yamiz:

$$u' \cos x = \cos x \quad \text{yoki} \quad u' = 1.$$

Bundan

$$u = x + C.$$

Berilgan tenglamaning umumiy yechimini topamiz:

$$z = uv, \quad z = (x + C) \cos x.$$

Bundan

$$y^{-1} = (x + C) \cos x \quad \text{yoki} \quad y = \frac{1}{(x + C) \cos x}.$$

Tenglamaning xususiy yechimni topish uchun ixtiyoriy o‘zgarmasning qiymatini boshlang‘ich shartdan topamiz:

$$\frac{1}{2} = \frac{1}{C} \quad \text{yoki} \quad C = 2.$$

Demak, tenglamaning izlanayotgan xususiy yechimi

$$y = \frac{1}{(x + 2) \cos x}. \quad \text{☞}$$

5. Differensial tenglamaning umumiy yechimini toping.

5.30. $\frac{2x(1 - e^y)}{(1 + x^2)^2} dx + \frac{e^y}{1 + x^2} dy = 0.$

☞ Tenglamada $M(x, y) = \frac{2x(1 - e^y)}{(1 + x^2)^2}, \quad N(x, y) = \frac{e^y}{1 + x^2}.$

Bundan

$$\frac{\partial M}{\partial y} = -\frac{2xe^y}{(1+x^2)^2}, \quad \frac{\partial N}{\partial x} = -\frac{2xe^y}{(1+x^2)^2}, \quad \text{ya'ni} \quad \frac{\partial M}{\partial y} = \frac{\partial N}{\partial x}.$$

Demak, tenglama to'liq differensialli.

$$\frac{\partial u}{\partial x} = M(x, y) = \frac{2x(1-e^y)}{(1+x^2)^2} \quad \text{tenglikni } x \text{ bo'yicha integrallaymiz:}$$

$$u = (1-e^y) \left(-\frac{1}{1+x^2} \right) + \varphi(y) \quad \text{yoki} \quad \varphi(y) = u + \frac{1-e^y}{1+x^2}.$$

Bundan

$$\varphi'(y) = \frac{\partial u}{\partial y} - \frac{e^y}{1+x^2}.$$

U holda

$$\frac{\partial u}{\partial y} = N(x, y) = \frac{e^y}{1+x^2}$$

ekanidan

$$\varphi'(y) = 0 \quad \text{yoki} \quad \varphi(y) = \bar{C}.$$

Demak,

$$u = \bar{C} + \frac{e^y - 1}{1+x^2} \quad \text{yoki} \quad \frac{e^y - 1}{1+x^2} = C. \quad \bullet$$

6. Differensial tenglamaning umumiy yechimini toping.

6.30. $2xy''y' = (y')^2 - 4.$

$\Rightarrow y' = p(x), \quad y'' = p'(x)$ o'rniga qo'yish bajaramiz:

$$2xpp' = p^2 - 4.$$

Bu tenglamada o'zgaruvchilarni ajratamiz:

$$2xp \frac{dp}{dx} = p^2 - 4 \quad \text{yoki} \quad \frac{2pdp}{p^2 - 4} = \frac{dx}{x}.$$

Integrallaymiz:

$$\ln |p^2 - 4| = \ln C_1 + \ln x.$$

Bundan

$$p = \sqrt{C_1 x + 4}.$$

y o'zgaruvchiga qaytamiz:

$$y' = \sqrt{C_1 x + 4}.$$

Bundan

$$y = \int \sqrt{C_1 x + 4} dx + C_2 \quad \text{yoki} \quad y = \frac{2}{3C_1} (C_1 x + 4)^{\frac{3}{2}} + C_2. \quad \bullet$$

7. Tenglamani ixtiyoriy o'zgarmlarni variatsiyalash usuli bilan yeching.

$$7.30. y'' + 9y = \frac{1}{\sin 3x}.$$

☞ $k^2 + 9 = 0$ xarakteristik tenglama $k_{1,2} = \pm 3i$ ildizlarga ega. U holda mos bir jinsli tenglamaning umumiy yechimi $y_1 = C_1 \cos 3x + C_2 \sin 3x$ ko'rinishda bo'ladi.

Berilgan tenglamaning xususiy yechimini

$$\bar{y} = C_1(x) \cos 3x + C_2(x) \sin 3x$$

ko'rinishda izlaymiz.

$C_1(x)$ va $C_2(x)$ funksiyalarni topish uchun

$$\begin{cases} C_1'(x) \cos 3x + C_2'(x) \sin 3x = 0, \\ -3C_1'(x) \sin 3x + 3C_2'(x) \cos 3x = \frac{1}{\sin 3x} \end{cases}$$

sistemani tuzamiz va yechamiz:

$$C_1'(x) = -\frac{1}{3}, \quad C_2'(x) = \frac{1}{3} \operatorname{ctg} 3x.$$

Bundan

$$C_1(x) = -\frac{1}{3}x, \quad C_2(x) = \frac{1}{9} \ln |\sin 3x|.$$

Demak, berilgan tenglamaning xususiy yechimini

$$\bar{y} = -\frac{1}{3}x \cos 3x + \frac{1}{9} \ln |\sin 3x| \sin 3x$$

va umumiy yechimi

$$y = C_1 \cos 3x + C_2 \sin 3x - \frac{1}{3}x \cos 3x + \frac{1}{9} \ln |\sin 3x| \sin 3x$$

yoki

$$y = \left(C_1 - \frac{1}{3}x \right) \cos 3x + \left(C_2 + \frac{1}{9} \ln |\sin 3x| \right) \sin 3x. \quad \ominus$$

8. $f_1(x)$, $f_2(x)$ berilgan. $y'' + 2y' = f_1(x) + f_2(x)$ differensial tenglamaning umumiy yechimini toping.

$$8.30. f_1(x) = 6e^x (\cos x + \sin x), \quad f_2(x) = e^{-2x} (5x - 2).$$

☞ $k^2 + 2k = 0$ xarakteristik tenglama $k_1 = 0$, $k_2 = -2$ ildizlarga ega. Mos bir jinsli tenglamaning umumiy yechimi $y = C_1 + C_2 e^{-2x}$ ga teng.

Tenglamaning o'ng tomoni ikkita $f_1(x) = 6e^x (\cos x + \sin x)$ va $f_2(x) = e^{-2x} (5x - 2)$ funksiyalarning yig'indisidan iborat. Shu sababli ikkita

bir jinsli bo‘lmagan

$$y'' + 2y' = 6e^x(\cos x + \sin x) \quad \text{va} \quad y'' + 2y' = e^{-2x}(5x - 2)$$

tenglamalarni yechamiz.

Birinchi tenglamaning o‘ng tomoni $f(x) = e^{\alpha}(P_n(x)\cos \beta x + Q_m(x)\sin \beta x)$ ko‘rinishda berilgan. Bunda $\alpha = 1$, $\beta = 1$, $P_0(x) = 6$, $Q_0(x) = 6$, $\alpha \pm i\beta = 1 \pm i$ xarakteristik tenglamaning ildizi emas.

U holda tenglamaning xususiy yechimini

$$\bar{y}_1 = e^x(A\cos x + B\sin x)$$

ko‘rinishda izlaymiz.

$\bar{y}'_1 = e^x((A+B)\cos x + (B-A)\sin x)$, $\bar{y}''_1 = e^x(2B\cos x - 2A\sin x)$ larni berilgan tenglamaga qo‘yamiz:

$$e^x(2B\cos x - 2A\sin x) + 2e^x((A+B)\cos x + (B-A)\sin x) = 6e^x(\cos x + \sin x).$$

Chap va o‘ng tomondagi $\cos x$ va $\sin x$ lar oldidagi koeffitsiyentlarni tenglab, topamiz: $A = -\frac{3}{5}$, $B = \frac{9}{5}$.

Demak, birinchi tenglamaning xususiy yechimi

$$\bar{y}_1 = \frac{3}{5}e^x(3\sin x - \cos x).$$

Ikkinchi tenglamaning o‘ng tomoni $f(x) = e^{\alpha}P_n(x)$ ko‘rinishda berilgan. Bunda $\alpha = -2$, $P_1(x) = 5x - 2$. $\alpha = -2$ xarakteristik tenglamaning bir karrali ildizi.

Tenglamaning xususiy yechimini

$$\bar{y}_2 = xe^{-2x}(Cx + D)$$

ko‘rinishda izlaymiz.

$$\bar{y}'_2 = e^{-2x}(2Cx^2 + (2C - 2D)x + D), \quad \bar{y}''_2 = e^{-2x}(4Cx^2 + (4D - 8C)x + 2C - 4D)$$

larni berilgan tenglamaga qo‘yamiz:

$$e^{-2x}(4Cx^2 + (4D - 8C)x + 2C - 4D) + 2e^{-2x}(-2Cx^2 + (2C - 2D)x + D) = e^{-2x}(Cx + D)$$

Bundan $C = -\frac{5}{4}$, $D = -\frac{1}{4}$.

Demak, ikkinchi tenglamaning xususiy yechimi

$$\bar{y}_2 = -\frac{1}{4}e^{-2x}x(5x + 1).$$

Shunday qilib, berilgan tenglamaning umumiy yechimi

$$y = C_1 + C_2e^{-2x} + \frac{3}{5}e^x(3\sin x - \cos x) - \frac{1}{4}e^{-2x}x(5x + 1). \quad \odot$$

9. Differensial tenglamalar sistemasining umumiy yechimini toping.

$$9.30. \begin{cases} y_1' = y_1 + y_2 + \sin x, \\ y_2' = 3y_1 - y_2 - \cos x. \end{cases}$$

☞ 1) Sistemaga mos bir jinsli tenglamani tuzamiz:

$$\begin{cases} y_1' = y_1 + y_2, \\ y_2' = 3y_1 - y_2. \end{cases}$$

Sistemaning xarakteristik tenglamasini tuzamiz va yechamiz:

$$\begin{vmatrix} 1-\lambda & 1 \\ 3 & -1-\lambda \end{vmatrix} = 0, \quad \lambda_1 = -2, \quad \lambda_2 = 2.$$

$\lambda_1 = -2$ da $3\alpha_{11} + \alpha_{21} = 0$ tenglikdan $\alpha_{21} = -3\alpha_{11}$ yoki $\alpha_{11} = 1$ desak, $\alpha_{21} = -3$ kelib chiqadi.

$\lambda_2 = 2$ da shu kabi topamiz: $\alpha_{12} = 1, \alpha_{22} = 1$.

U holda bir jinsli sistemaning yechimi

$$\begin{cases} y_1 = C_1 e^{-2x} + C_2 e^{2x}, \\ y_2 = -3C_1 e^{-2x} + C_2 e^{2x} \end{cases}$$

bo'ladi.

Berilgan sistemaning xususiy yechimini

$$\begin{cases} \bar{y}_1 = A_1 \cos x + B_1 \sin x, \\ \bar{y}_2 = A_2 \cos x + B_2 \sin x \end{cases}$$

ko'rinishda izlaymiz. Bundan

$$\begin{cases} \bar{y}_1' = -A_1 \sin x + B_1 \cos x, \\ \bar{y}_2' = -A_2 \sin x + B_2 \cos x. \end{cases}$$

$\bar{y}_1, \bar{y}_2, \bar{y}_1', \bar{y}_2'$ larni berilgan sistemaga qo'yamiz $\cos x$ va $\sin x$ lar oldidagi koeffitsiyentlarni tenglab, topamiz:

$$A_1 = 0, \quad B_1 = -\frac{1}{5}, \quad A_2 = -\frac{1}{5}, \quad B_2 = -\frac{4}{5}.$$

Demak, berilgan sistemaning xususiy yechimi va umumiy yechimi:

$$\begin{cases} \bar{y}_1 = -\frac{1}{5} \sin x, \\ \bar{y}_2 = -\frac{1}{5} \cos x - \frac{4}{5} \sin x \end{cases}$$

$$\begin{cases} y_1 = C_1 e^{-2x} + C_2 e^{2x} - \frac{1}{5} \sin x, \\ y_2 = -3C_1 e^{-2x} + C_2 e^{2x} - \frac{1}{5} \cos x - \frac{4}{5} \sin x. \quad \ominus \end{cases}$$

IY bob

SONLI VA FUNKSIONAL QATORLAR

4.1. SONLI QATORLAR

Sonli qatorlarning xossalari. Qator yaqinlashishining zaruriy alomati.

Musbat hadli qatorning yaqinlashish alomatlari.

Ishora almashinuvchi qatorlar. Leybnis alomati.

O'zgaruvchan ishorali qatorlar. Absolut va shartli yaqinlashish

☐ **4.1.1.** $a_1, a_2, \dots, a_n, \dots$ haqiqiy yoki kompleks sonlar ketma-ketligidan hosil qilingan

$$a_1 + a_2 + a_3 + \dots + a_n + \dots = \sum_{n=1}^{\infty} a_n$$

ifodaga *sonli qator (qator)* deyiladi. Bunda $a_1, a_2, \dots, a_n, \dots$ – qatorning hadlari, a_n – qatorning umumiy hadi deb ataladi

☐ Qatorning birinchi n ta hadlarining yig'indisi S_n ga qatorning n -qismaniy yig'indisi deyiladi.

☐ Agar qismaniy yig'indilar ketma-ketligi $\{S_n\}$ ketma-ketlik chekli limitga ega, ya'ni $\lim_{n \rightarrow \infty} S_n = S$ bo'lsa, $\sum_{n=1}^{\infty} a_n$ qatorga *yaqinlashuvchi qator* deyiladi. Bunda S qatorning *yig'indisi* deb ataladi va $S = \sum_{n=1}^{\infty} a_n$ kabi yoziladi.

☐ Agar $\{S_n\}$ ketma-ketlik chekli limitga ega bo'lmasa, $\sum_{n=1}^{\infty} a_n$ qatorga *uzoqlashuvchi qator* deyiladi.

1-misol. Qatorlarni yaqinlashishga tekshiring. Yaqinlashuvchi qatorlarning yig'indisini toping:

$$1) \sum_{n=1}^{\infty} \frac{1}{9n^2 + 3n - 2}; \quad 2) \sum_{n=1}^{\infty} \ln\left(1 + \frac{1}{n}\right); \quad 3) \sum_{n=1}^{\infty} aq^{n-1}.$$

☞ 1) Qatorning umumiy hadini sodda kasrlar yig'indisiga keltiramiz:

$$a_n = \frac{1}{9n^2 + 3n - 2} = \frac{1}{(3n-1)(3n+2)} = \frac{1}{3} \left(\frac{1}{3n-1} - \frac{1}{3n+2} \right).$$

Bundan

$$a_1 = \frac{1}{3} \left(\frac{1}{2} - \frac{1}{5} \right), \quad a_2 = \frac{1}{3} \left(\frac{1}{5} - \frac{1}{8} \right), \quad a_3 = \frac{1}{3} \left(\frac{1}{8} - \frac{1}{11} \right), \quad a_4 = \frac{1}{3} \left(\frac{1}{11} - \frac{1}{14} \right), \dots$$

U holda

$$S_n = \frac{1}{3}\left(\frac{1}{2} - \frac{1}{5}\right) + \frac{1}{3}\left(\frac{1}{5} - \frac{1}{8}\right) + \frac{1}{3}\left(\frac{1}{8} - \frac{1}{11}\right) + \frac{1}{3}\left(\frac{1}{11} - \frac{1}{14}\right) + \dots + \frac{1}{3}\left(\frac{1}{3n-1} - \frac{1}{3n+2}\right) = \\ = \frac{1}{3}\left(\frac{1}{2} - \frac{1}{5} + \frac{1}{5} - \frac{1}{8} + \frac{1}{8} - \frac{1}{11} + \frac{1}{11} - \frac{1}{14} + \dots + \frac{1}{3n-1} - \frac{1}{3n+2}\right) = \frac{1}{3}\left(\frac{1}{2} - \frac{1}{3n+2}\right).$$

Bundan

$$\lim_{n \rightarrow \infty} S_n = \lim_{n \rightarrow \infty} \frac{1}{3}\left(\frac{1}{2} - \frac{1}{3n+2}\right) = \frac{1}{6}.$$

Demak, qator yaqinlashadi va uning yig'indisi $\frac{1}{6}$ ga teng.

2) Qatorning umumiy hadida almashtirishlar bajaramiz:

$$a_n = \ln\left(1 + \frac{1}{n}\right) = \ln\left(\frac{n+1}{n}\right) = \ln(n+1) - \ln n.$$

Bundan

$$S_n = \ln 2 - \ln 1 + \ln 3 - \ln 2 + \ln 4 - \ln 3 + \dots + \ln(n+1) - \ln n = \ln(n+1),$$

$$\lim_{n \rightarrow \infty} S_n = \lim_{n \rightarrow \infty} \ln(n+1) = +\infty.$$

Demak, qator uzoqlashadi.

3) $\sum_{n=1}^{\infty} aq^{n-1}$ qator (geometrik progressiya) uchun elementar matematika

kursidan ma'lumki, $S_n = a \frac{1-q^n}{1-q}$, $q \neq 1$, ya'ni

$$\lim_{n \rightarrow \infty} S_n = \lim_{n \rightarrow \infty} \frac{a}{1-q} \cdot (1-q^n) = \begin{cases} \frac{a}{1-q}, & |q| < 1, \\ \infty, & |q| > 1. \end{cases}$$

$q=1$ da $S_n = a + a + \dots + a = na$, $\lim_{n \rightarrow \infty} S_n = \lim_{n \rightarrow \infty} na = +\infty$, $q=-1$ da

$S_n = a - a + a - a + \dots$, ya'ni n juft bo'lganda $S_n = 0$ va n toq bo'lganda $S_n = a$.

Shunday qilib, geometrik progressiya $|q| < 1$ da yaqinlashadi va uning

yig'indisi $S = \frac{a}{1-q}$ ga teng bo'ladi, $|q| \geq 1$ da uzoqlashadi. 

Sonli qatorlar quyidagi xossalarga ega.

1°. Agar $\sum_{n=1}^{\infty} a_n$ qator yaqinlashuvchi va uning yig'indisi S ga teng bo'lsa,

u holda $\sum_{n=1}^{\infty} \lambda a_n$ qator ham yaqinlashadi va uning yig'indisi $\lambda \cdot S$ ga teng bo'ladi, bu yerda λ – ixtiyoriy son.

2°. Agar $\sum_{n=1}^{\infty} a_n$ va $\sum_{n=1}^{\infty} b_n$ qatorlar yaqinlashuvchi va ularning yig'indilari mos ravishda S_1 va S_2 ga teng bo'lsa, $\sum_{n=1}^{\infty} (a_n \pm b_n)$ qator ham yaqinlashadi va uning yig'indisi $S_1 \pm S_2$ ga teng bo'ladi.

3°. Agar $\sum_{n=1}^{\infty} a_n$ qator yaqinlashuvchi bo'lsa, bu qatordan chekli sondagi birinchi k ta hadlarni tashlab yuborish natijasida hosil qilingan $\sum_{n=k+1}^{\infty} a_n$ qator ham yaqinlashadi va aksincha, agar $\sum_{n=k+1}^{\infty} a_n$ yaqinlashuvchi bo'lsa, bu qatorga chekli sondagi hadlarni qo'shish natijasida hosil qilingan $\sum_{n=1}^{\infty} a_n$ qator ham yaqinlashadi.

☑ $\sum_{n=1}^{\infty} a_n$ qatordan hosil qilingan $r_n = \sum_{i=n+1}^{\infty} a_i$ qatorga uning n -qoldig'i deyiladi.

1-natija. Agar qator yaqinlashuvchi bo'lsa, uning istalgan qoldig'i yaqinlashadi va aksincha, qoldig'i yaqinlashuvchi bo'lgan har qanday qator yaqinlashuvchi bo'ladi.

2-natija. Agar qator yaqinlashuvchi bo'lsa, $\lim_{n \rightarrow \infty} r_n = 0$ bo'ladi.

4.1.2. 1-teorema (Koshi kriteriyasi) $\sum_{n=1}^{\infty} a_n$ qator yaqinlashishi uchun istalgan $\varepsilon > 0$ sonda shunday $N = N(\varepsilon)$ nomer topilishi va barcha $n > N$, $p = 0, 1, 2, \dots$ lar uchun $|S_{n+p} - S_{n-1}| < \varepsilon$ bo'lishi zarur va yetarli.

2-misol. $\sum_{n=1}^{\infty} \frac{1}{n}$ qatorni yaqinlashishga tekshiring.

☞ $\sum_{n=1}^{\infty} \frac{1}{n}$ qatorga *garmonik qator* deyiladi. Bu qatorning $2n$ va n -qismiy yig'indilari ayirmasini qaraymiz:

$$S_{2n} - S_n = \frac{1}{n+1} + \frac{1}{n+2} + \dots + \frac{1}{2n}.$$

Bunda har bir qo'shiluvchini ulardan kichik bo'lgan $\frac{1}{2n}$ kattalik bilan

almashtiramiz: $S_{2n} - S_n > \frac{1}{2n} + \frac{1}{2n} + \dots + \frac{1}{2n} = n \cdot \frac{1}{2n} = \frac{1}{2}.$

Bu tengsizlik garmonik qator uchun $p = n$ da Koshi kriteriyasining bajarilmasligini bildiradi. Demak, qator uzoqlashadi. ☹

2-teorema (*qator yaqinlashishining zaruriy alomati*). Agar $\sum_{n=1}^{\infty} a_n$ qator yaqinlashuvchi bo'lsa, u holda $\lim_{n \rightarrow \infty} a_n = 0$ bo'ladi.

3-natija (*qator uzoqlashishining yetarli alomati*). Agar $n \rightarrow \infty$ da qatorning umumiy hadi nolga intilmasa, u holda qator uzoqlashadi.

3-misol. $\sum_{n=1}^{\infty} \frac{n^2}{n^2 + 3n - 2}$ qatorni yaqinlashishga tekshiring.

☞ Berilgan qator uchun

$$\lim_{n \rightarrow \infty} a_n = \lim_{n \rightarrow \infty} \frac{n^2}{n^2 + 3n - 2} = 1 \neq 0.$$

Qator uzoqlashishining zaruriy alomatiga ko'ra bu qator uzoqlashadi. ☞

4.1.3. 3-teorema (*taqqoslash alomati*). $\sum_{n=1}^{\infty} a_n$ va $\sum_{n=1}^{\infty} b_n$ musbat hadli qatorlar berilgan bo'lib, n ning biror n_0 ($n_0 \geq 1$) qiymatidan boshlab barcha $n \geq n_0$ lar uchun $a_n \leq b_n$ tengsizlik bajarilsin. U holda $\sum_{n=1}^{\infty} b_n$ qatorning yaqinlashuvchi bo'lishidan $\sum_{n=1}^{\infty} a_n$ qatorning yaqinlashuvchi bo'lishi kelib chiqadi va $\sum_{n=1}^{\infty} a_n$ qatorning uzoqlashuvchi bo'lishidan $\sum_{n=1}^{\infty} b_n$ qatorning uzoqlashuvchi bo'lishi kelib chiqadi.

4-teorema (*taqqoslashning limit alomati*). Agar musbat hadli $\sum_{n=1}^{\infty} a_n$ va $\sum_{n=1}^{\infty} b_n$ qatorlar uchun $\lim_{n \rightarrow \infty} \frac{a_n}{b_n} = A$ ($0 \leq A < \infty$) bo'lsa, u holda har ikkala qator bir vaqtda yaqinlashadi yoki bir vaqtda uzoqlashadi.

5-teorema (*Dalamber alomati*). Agar $\sum_{n=1}^{\infty} a_n$ qator uchun qandaydir $n = n_0$ nomerdan boshlab $\lim_{n \rightarrow \infty} \frac{a_{n+1}}{a_n} = l$ limit mavjud bo'lsa, u holda $l < 1$ da qator yaqinlashadi va $l > 1$ da qator uzoqlashadi.

6-teorema (*Koshining ildiz alomati*). Agar $\sum_{n=1}^{\infty} a_n$ qator uchun qandaydir $n = n_0$ nomerdan boshlab $\lim_{n \rightarrow \infty} \sqrt[n]{a_n} = l$ limit mavjud bo'lsa, u holda $l < 1$ da qator yaqinlashadi va $l > 1$ da qator uzoqlashadi.

Izoh. Dalamber va Koshining ildiz alomatlarida $l = 1$ bo'lganda qator yaqinlashishi ham uzoqlashishi ham mumkin. Bunda qatorning yaqinlashishi

boshqa yetarli alomatlar bilan tekshiriladi.

7-teorema (*Koshining integral alomati*). $\sum_{n=1}^{\infty} a_n$ qatorning hadlari $[1; +\infty)$ oraliqda aniqlangan musbat, monoton kamayuvchi $f(x)$ funksiyaning $x=1, 2, \dots, n, \dots$ dagi qiymatlaridan iborat, ya'ni $a_1 = f(1), a_2 = f(2), \dots, a_n = f(n), \dots$ bo'lsin. U holda $\int_1^{+\infty} f(x) dx$ xosmos integral yaqinlashsa, qator ham yaqinlashadi va $\int_1^{+\infty} f(x) dx$ xosmos integral uzoqlashsa, qator ham uzoqlashadi.

4-misol. Musbat hadli qatorlarni yaqinlashishga tekshiring:

$$1) \sum_{n=1}^{\infty} \frac{1}{3^n + \sqrt{n}};$$

$$2) \sum_{n=1}^{\infty} \frac{2n-1}{n^2 + 5n};$$

$$3) \sum_{n=1}^{\infty} \frac{n^3}{2^n};$$

$$4) \sum_{n=1}^{\infty} \frac{a^n}{n!};$$

$$5) \sum_{n=1}^{\infty} \frac{1}{2^n} \cdot \left(\frac{n+1}{n}\right)^{n^2};$$

$$6) \sum_{n=1}^{\infty} \frac{1}{n^\alpha}, \quad (\alpha > 0).$$

☉ 1) $\sum_{n=1}^{\infty} \frac{1}{3^n}$ yaqinlashuvchi qatorni olamiz. Berilgan qatorning hadlari uchun

$$\frac{1}{3^n + \sqrt{n}} < \frac{1}{3^n}, \quad n = 1, 2, \dots$$

tengsizlik bajariladi.

U holda taqqoslash alomatiga ko'ra berilgan qator yaqinlashadi.

2) Berilgan va garmonik qatorlar hadlari nisbatlarining limitini topamiz:

$$\lim_{n \rightarrow \infty} \frac{2n-1}{n^2 + 5n} \cdot n = \lim_{n \rightarrow \infty} \frac{2n-1}{n+5} = 2.$$

Garmonik qator uzoqlashuvchi bo'lgani uchun taqqoslashning limit alomatiga ko'ra berilgan qator uzoqlashadi.

$$3) \text{ Berilgan qatorda } a_n = \frac{n^3}{2^n}, \quad a_{n+1} = \frac{(n+1)^3}{2^{n+1}}.$$

U holda

$$\lim_{n \rightarrow \infty} \frac{a_{n+1}}{a_n} = \lim_{n \rightarrow \infty} \frac{(n+1)^3 \cdot 2^n}{2^{n+1} \cdot n^3} = \lim_{n \rightarrow \infty} \frac{1}{2} \left(\frac{n+1}{n}\right)^3 = \frac{1}{2} < 1.$$

Demak, Dalamber alomatiga ko'ra qator yaqinlashadi.

4) Berilgan qator uchun $a_n = \frac{a^n}{n!}$, $a_{n+1} = \frac{a^{n+1}}{(n+1)!}$ va

$$\lim_{n \rightarrow \infty} \frac{a_{n+1}}{a_n} = \lim_{n \rightarrow \infty} \frac{a^{n+1} \cdot n!}{a^n \cdot (n+1)!} = \lim_{n \rightarrow \infty} \frac{a}{n+1} = 0 < 1.$$

Demak, Dalamber alomatiga ko'ra qator yaqinlashadi.

5) Qatorni yaqinlashishga Koshining ildiz alomati bilan tekshiramiz:

$$\lim_{n \rightarrow \infty} \sqrt[n]{a_n} = \lim_{n \rightarrow \infty} \sqrt[n]{\frac{1}{2^n} \cdot \left(\frac{n+1}{n}\right)^{n^2}} = \lim_{n \rightarrow \infty} \frac{1}{2} \cdot \left(\frac{n+1}{n}\right)^n = \frac{1}{2} \cdot \lim_{n \rightarrow \infty} \left(1 + \frac{1}{n}\right)^n = \frac{e}{2} > 1.$$

Demak, qator uzoqlashadi.

6) $\sum_{n=1}^{\infty} \frac{1}{n^\alpha}$ ($\alpha > 0$) qatorga *umumlashgan garmonik* qator deyiladi.

Bu qatorga mos $[1; +\infty)$ oraliqda aniqlangan, uzluksiz, monoton kamayuvchi $f(x) = \frac{1}{x^\alpha}$ funksiyani olamiz.

U holda agar $\alpha \neq 1$ da

$$\int_1^{\infty} f(x) dx = \lim_{b \rightarrow \infty} \int_1^b \frac{dx}{x^\alpha} = \lim_{b \rightarrow \infty} \left. \frac{x^{1-\alpha}}{1-\alpha} \right|_1^b = \frac{1}{1-\alpha} (\lim_{b \rightarrow \infty} b^{1-\alpha} - 1).$$

Bu integral $\alpha > 1$ da yaqinlashadi va $\alpha < 1$ da uzoqlashadi.

Demak, Koshining integral alomatiga ko'ra umumlashgan garmonik qator $\alpha > 1$ da yaqinlashadi va $0 < \alpha < 1$ da uzoqlashadi.

$\alpha = 1$ bo'lganda bu qatordan uzoqlashuvchi $\sum_{n=1}^{\infty} \frac{1}{n}$ garmonik qator kelib chiqadi. Shunday qilib, umumlashgan garmonik qator $\alpha > 1$ da yaqinlashadi va $0 < \alpha \leq 1$ da uzoqlashadi. 

4.1.4.  Agar qatorning har bir musbat hadidan keyin manfiy had kelsa va har bir manfiy hadidan keyin musbat had kelsa, bu qatorga *ishora almashinuvchi* qator deyiladi.

Ishora almashinuvchi qatorni $\sum_{n=1}^{\infty} (-1)^{n+1} a_n$, ($a_n > 0$) kabi yozish mumkin.

7-teorema (Leybnits alomati). Agar $\sum_{n=1}^{\infty} (-1)^{n+1} a_n$ qatorida $\{a_n\}$ ketma-ketlik kamayuvchi, ya'ni $a_{n+1} < a_n$ ($n = 1, 2, \dots$) va $\lim_{n \rightarrow \infty} a_n = 0$ bo'lsa, u holda bu qator yaqinlashadi va uning yig'indisi $0 < S < a_1$ tengsizlikni qanoatlantiradi.

5-misol. Ishora almashinuvchi qatorlarni yaqinlashishga tekshiring:

$$1) \sum_{n=1}^{\infty} (-1)^{n+1} \frac{1}{n(n+1)^2}; \quad 2) \sum_{n=1}^{\infty} \frac{\cos(n+1)\pi}{n};$$

$$3) \sum_{n=1}^{\infty} (-1)^{n+1} \frac{n+2}{n+1}; \quad 4) \sum_{n=1}^{\infty} (-1)^{n-1} \frac{3^n}{n^3}.$$

☉ Ishora almashinuvchi qator yaqinlashishga Leybnits alomati bilan tekshiriladi. Berilgan qatorlar uchun Leybnits alomatining shartlarini tekshiramiz.

1) Berilgan qator uchun $a_n = \frac{1}{n(n+1)^2}$.

Bunda

$$1) \frac{1}{1 \cdot 2^2} > \frac{1}{2 \cdot 3^2} > \frac{1}{3 \cdot 4^2} > \dots > \frac{1}{n(n+1)^2} > \dots, \quad 2) \lim_{n \rightarrow \infty} \frac{1}{n(n+1)^2} = 0.$$

Demak, qator yaqinlashadi.

2) $\sum_{n=1}^{\infty} \frac{\cos(n+1)\pi}{n}$ qatorni $\sum_{n=1}^{\infty} (-1)^{n+1} \frac{1}{n}$ kabi yozib olamiz.

U holda

$$1) \frac{1}{1} > \frac{1}{2} > \frac{1}{3} > \dots > \frac{1}{n} > \dots, \quad 2) \lim_{n \rightarrow \infty} \frac{1}{n} = 0.$$

Leybnits alomatiga ko‘ra qator yaqinlashadi.

3) $\sum_{n=1}^{\infty} (-1)^{n+1} \frac{n+2}{n+1}$ qator uchun

$$1) \frac{3}{2} > \frac{4}{3} > \frac{5}{4} > \dots > \frac{n+2}{n+1} > \dots, \quad 2) \lim_{n \rightarrow \infty} \frac{n+2}{n+1} = 1 \neq 0.$$

Demak, Leybnits alomatining ikkinchi sharti bajarilmaydi. Shuning uchun qator uzoqlashadi.

4) $a_n = \frac{3^n}{n^3}$ had uchun

$$\frac{3}{1} > \frac{9}{4} > \frac{27}{27} < \frac{81}{64}$$

bo‘ladi, ya’ni $n \geq 4$ larda Leybnits alomatining birinchi sharti bajarilmaydi.

Demak, qator uzoqlashadi. ☹

4.1.5. Ham musbat va ham manfiy hadlardan tashkil topgan $\sum_{n=1}^{\infty} a_n$ qatorga o‘zgaruvchi ishorali (ixtiyoriy hadli) qator deyiladi.

☐ Agar $\sum_{n=1}^{\infty} a_n$ qator hadlarining absolut qiymatlaridan tashkil topgan

$\sum_{n=1}^{\infty} |a_n|$ qator yaqinlashuvchi bo'lsa, $\sum_{n=1}^{\infty} a_n$ qatorga *absolut yaqinlashuvchi qator* deyiladi.

☐ Agar $\sum_{n=1}^{\infty} a_n$ qator yaqinlashuvchi bo'lib, $\sum_{n=1}^{\infty} |a_n|$ qator uzoqlashuvchi bo'lsa, $\sum_{n=1}^{\infty} a_n$ qatorga *shartli yaqinlashuvchi qator* deyiladi.

8-teorema (*o'zgaruvchi ishorali qator yaqinlashishining yetarlilik alomati*). Agar $\sum_{n=1}^{\infty} |a_n|$ qator yaqinlashuvchi bo'lsa, u holda $\sum_{n=1}^{\infty} a_n$ qator ham yaqinlashadi, ya'ni absolut yaqinlashuvchi qator oddiy ma'noda ham yaqinlashuvchi bo'ladi.

5-misol. Qatorlarni shartli yoki absolut yaqinlashishga tekshiring:

$$1) \sum_{n=1}^{\infty} \frac{\cos n\alpha}{(\ln 10)^n};$$

$$3) \sum_{n=1}^{\infty} (-1)^{\frac{n^2+n}{2}} \frac{n}{3^n};$$

$$3) \sum_{n=1}^{\infty} (-1)^{n+1} \frac{1}{4n+5};$$

$$4) \sum_{n=3}^{\infty} (-1)^n \frac{1}{n \ln n \sqrt{n \ln n}}.$$

☑ 1) Qator o'zgaruvchi ishorali. α ning har qanday qiymatida $\lim_{n \rightarrow \infty} \frac{\cos n\alpha}{(\ln 10)^n} = 0$ bo'lgani uchun qator yaqinlashishi mumkin. Bu qator hadlarining absolut qiymatlaridan tashkil topgan $\sum_{n=1}^{\infty} \frac{|\cos n\alpha|}{(\ln 10)^n}$ qatorni qaraymiz.

Bu qatorning hadlari $\sum_{n=1}^{\infty} \frac{1}{(\ln 10)^n}$ qator mos hadlaridan katta bo'lmaydi.

$\sum_{n=1}^{\infty} \frac{1}{(\ln 10)^n}$ qator Koshining ildiz alomatiga ko'ra yaqinlashadi:

$$\lim_{n \rightarrow \infty} \sqrt[n]{\frac{1}{(\ln 10)^n}} = \lim_{n \rightarrow \infty} \frac{1}{\ln 10} < 1.$$

Demak, $\sum_{n=1}^{\infty} \frac{|\cos n\alpha|}{(\ln 10)^n}$ qator yaqinlashadi. U holda 8-teoremaga ko'ra berilgan qator absolut yaqinlashadi.

2) Qatorning yoyilmasini yozamiz:

$$\sum_{n=1}^{\infty} (-1)^{\frac{n^2+n}{2}} \frac{n}{3^n} = -\frac{1}{3} - \frac{2}{9} + \frac{3}{27} + \frac{4}{81} + \dots$$

Demak, qator o‘zgaruvchi ishorali.

Bu qator hadlarining absolut qiymatlaridan tashkil topgan $\sum_{n=1}^{\infty} \frac{n}{3^n}$ qatorni

Dalamber alomati bilan yaqinlashishga tekshiramiz:

$$\lim_{n \rightarrow \infty} \frac{a_{n+1}}{a_n} = \lim_{n \rightarrow \infty} \frac{(n+1) \cdot 3^n}{3^{n+1} \cdot n^3} = \frac{1}{3} < 1.$$

$\sum_{n=1}^{\infty} \frac{n}{3^n}$ qator yaqinlashdi. Demak, berilgan qator absolut yaqinlashadi.

3) Qator ishora almashinuvchi.

Bu qator hadlari uchun Leybnits alomatining shartlarini tekshiramiz:

$$1) \frac{1}{9} > \frac{1}{13} > \frac{1}{17} > \dots > \frac{1}{4n+5} > \dots, \quad 2) \lim_{n \rightarrow \infty} \frac{1}{4n+5} = 0.$$

Demak, berilgan qator yaqinlashadi. Bu qator hadlarining absolut qiymatlaridan tashkil topgan $\sum_{n=1}^{\infty} \frac{1}{4n+5}$ qator uzoqlashadi.

Shunday qilib, berilgan qator shartli yaqinlashadi.

4) Berilgan qator uchun Leybnits alomatining har ikkala sharti bajariladi:

$$1) \frac{1}{3 \ln 3 \sqrt{\ln \ln 3}} > \frac{1}{4 \ln 4 \sqrt{\ln \ln 4}} > \dots > \frac{1}{n \ln n \sqrt{\ln \ln n}} > \dots, \quad 2) \lim_{n \rightarrow \infty} \frac{1}{n \ln n \sqrt{\ln \ln n}} = 0.$$

Demak, qator yaqinlashadi.

$\sum_{n=3}^{\infty} \frac{1}{n \ln n \sqrt{\ln \ln n}}$ qatorni yaqinlashishga Koshining integral alomati bilan tekshiramiz:

$$\begin{aligned} \int_3^{+\infty} \frac{dx}{x \ln x \sqrt{\ln \ln x}} &= \lim_{b \rightarrow \infty} \int_3^b \frac{dx}{x \ln x \sqrt{\ln \ln x}} = \\ &= \left(\ln \ln x = t, \frac{dx}{x \ln x} = dt \right) = \lim_{b \rightarrow \infty} \int_{\ln \ln 3}^{\ln \ln b} \frac{dt}{\sqrt{t}} = \\ &= \lim_{b \rightarrow \infty} 2\sqrt{t} \Big|_{\ln \ln 3}^{\ln \ln b} = 2\sqrt{\ln \ln(+\infty)} - 2\sqrt{\ln \ln 3} = +\infty. \end{aligned}$$

Bundan $\sum_{n=3}^{\infty} \frac{1}{n \ln n \sqrt{\ln \ln n}}$ qatorning uzoqlashishi kelib chiqadi.

Demak, berilgan qator shartli yaqinlashadi. 

Mashqlar

4.1.1. Qatorlarni yaqinlashishga tekshiring. Yaqinlashuvchi qatorning yig'indisini toping:

- 1) $\sum_{n=1}^{\infty} \frac{1}{n(n+3)}$;
- 2) $\sum_{n=1}^{\infty} \frac{1}{(2n+5)(2n+7)}$;
- 3) $\sum_{n=1}^{\infty} \frac{1}{9n^2 + 21n + 10}$;
- 4) $\sum_{n=1}^{\infty} \frac{1}{4n^2 + 4n - 3}$;
- 5) $\sum_{n=1}^{\infty} \frac{2n+1}{n^2(n+1)^2}$;
- 6) $\sum_{n=1}^{\infty} \frac{4n}{(2n-1)^2(2n+1)^2}$;
- 7) $\sum_{n=1}^{\infty} (-1)^n(3n-1)$;
- 8) $\sum_{n=1}^{\infty} \left(\frac{7}{2} + (-1)^n \frac{3}{2} \right)$;
- 9) $\sum_{n=1}^{\infty} \frac{3^n + 5^n}{15^n}$;
- 10) $\sum_{n=1}^{\infty} \frac{1}{2^{n-3}}$;
- 11) $\sum_{n=1}^{\infty} \ln \left(\frac{4n-1}{3n+2} \right)$;
- 12) $\sum_{n=1}^{\infty} \operatorname{arcctg} \left(\frac{n+3}{n^2+1} \right)$.

4.1.2. Qatorlarni yaqinlashishga taqqoslash alomati bilan tekshiring:

- 1) $\sum_{n=1}^{\infty} \frac{1}{n^2+1}$;
- 2) $\sum_{n=1}^{\infty} \frac{1}{\ln(n+1)}$;
- 3) $\sum_{n=1}^{\infty} \left(1 - \cos \frac{\pi}{2^n} \right)$;
- 4) $\sum_{n=1}^{\infty} \frac{1}{3^{n+1} + 2}$.

4.1.3. Qatorlarni yaqinlashishga taqqoslashning limit alomati bilan tekshiring:

- 1) $\sum_{n=1}^{\infty} \operatorname{tg} \left(\frac{\pi}{4n} \right)$;
- 2) $\sum_{n=1}^{\infty} \sqrt{n} \sin \left(\frac{\pi}{n^2} \right)$;
- 3) $\sum_{n=1}^{\infty} \frac{3n^2 - 5}{n^4 + 4n}$;
- 4) $\sum_{n=1}^{\infty} \ln \left(\frac{n^2 + 1}{n^2} \right)$.

4.1.4. Qatorlarni yaqinlashishga Dalamber alomati bilan tekshiring:

- 1) $\sum_{n=1}^{\infty} \frac{n}{2^n}$;
- 2) $\sum_{n=1}^{\infty} \frac{4 \cdot 5 \cdot 6 \cdot \dots \cdot (n+3)}{5 \cdot 7 \cdot 9 \cdot \dots \cdot (2n+3)}$;
- 3) $\sum_{n=1}^{\infty} \frac{n!}{e^n}$;
- 4) $\sum_{n=1}^{\infty} \frac{n^n}{n!}$.

4.1.5. Qatorlarni yaqinlashishga Koshining ildiz alomati bilan tekshiring:

$$1) \sum_{n=1}^{\infty} \left(\frac{2n+1}{3n-2} \right)^{2n-2};$$

$$2) \sum_{n=1}^{\infty} \left(\operatorname{arctg} \frac{1}{3^n} \right)^{2n};$$

$$3) \sum_{n=1}^{\infty} \left(\frac{4n-1}{4n} \right)^{n^2};$$

$$4) \sum_{n=1}^{\infty} \frac{1}{2^n} \left(\frac{n+1}{n} \right)^{n^2}.$$

4.1.6. Qatorlarni yaqinlashishga Koshining integral alomati bilan tekshiring:

$$1) \sum_{n=1}^{\infty} \frac{1}{(3n-1)^2};$$

$$2) \sum_{n=1}^{\infty} \frac{n+2}{n^3 \sqrt{n}};$$

$$3) \sum_{n=2}^{\infty} \frac{1}{n \sqrt{\ln n}};$$

$$4) \sum_{n=1}^{\infty} \frac{1}{(3n+2) \ln^2(3n+2)}.$$

4.1.7. Qatorlarni yaqinlashishga tekshiring:

$$1) \sum_{n=1}^{\infty} \frac{1}{\sqrt{n}} \ln \left(\frac{n+1}{n-1} \right);$$

$$2) \sum_{n=1}^{\infty} \frac{2^{n-1}}{5^n + 3};$$

$$3) \sum_{n=2}^{\infty} \frac{\sqrt[3]{n^2} + \sqrt{n^2}}{\sqrt{n^4} + \sqrt{n^2}};$$

$$4) \sum_{n=1}^{\infty} \frac{(n+1)!}{2^n n!};$$

$$5) \sum_{n=1}^{\infty} \frac{3^{n-1}}{(n-1)!};$$

$$6) \sum_{n=1}^{\infty} \frac{(n!)^2}{(2n)!};$$

$$7) \sum_{n=2}^{\infty} \frac{n^{100}}{2^n};$$

$$8) \sum_{n=1}^{\infty} \frac{1}{3^n} \left(1 + \frac{1}{n} \right)^{n^2};$$

$$9) \sum_{n=2}^{\infty} \frac{1}{n \ln^2 n};$$

$$10) \sum_{n=3}^{\infty} \frac{1}{n \ln n (\ln \ln n)^2}.$$

4.1.8. Qator yaqinlashishining yetarli alomati asosida isbotlang:

$$1) \lim_{n \rightarrow \infty} \frac{a^n}{n!} = 0;$$

$$2) \lim_{n \rightarrow \infty} \frac{n^n}{(2n)!} = 0.$$

4.1.9. Ishora almashinuvchi qatorlarni yaqinlashishga tekshiring:

$$1) \sum_{n=1}^{\infty} (-1)^{n+1} \frac{1}{\sqrt{n}};$$

$$2) \sum_{n=2}^{\infty} (-1)^n \frac{\ln n}{n};$$

$$3) \sum_{n=1}^{\infty} (-1)^{n+1} \frac{n!}{1 \cdot 3 \cdot 5 \cdot \dots \cdot (2n-1)};$$

$$4) \sum_{n=1}^{\infty} (-1)^n \frac{1}{n^\alpha};$$

$$5) \sum_{n=1}^{\infty} (-1)^n \frac{n}{6n-5};$$

$$6) \sum_{n=1}^{\infty} (-1)^{n-1} \frac{2^n}{n^2}. \quad 9$$

4.1.10. Qatorlarni shartli yoki absolut yaqinlashishga tekshiring:

- | | |
|--|--|
| 1) $\sum_{n=1}^{\infty} \frac{\sin n\alpha}{(\ln 3)^n}$; | 2) $\sum_{n=1}^{\infty} \frac{\cos(n-1)\pi}{n^2 + 5}$; |
| 3) $\sum_{n=1}^{\infty} (-1)^n \frac{1}{\sqrt[4]{n^5}}$; | 4) $\sum_{n=1}^{\infty} (-1)^n \frac{1}{(n+1)\ln(n+1)}$; |
| 5) $\sum_{n=1}^{\infty} (-1)^n \frac{1}{\ln(n+1)}$; | 6) $\sum_{n=1}^{\infty} (-1)^{n+1} \left(1 + \frac{1}{3^n}\right)$; |
| 7) $\sum_{n=1}^{\infty} (-1)^n \frac{n^2 + 3}{4n^2 - 1}$; | 8) $\sum_{n=1}^{\infty} (-1)^n \sin\left(\frac{1}{n^2}\right)$; |
| 9) $\sum_{n=1}^{\infty} (-1)^n \left(\frac{2n-1}{3n+2}\right)^n$; | 10) $\sum_{n=1}^{\infty} (-1)^{n+1} \frac{5 \cdot 7 \cdot 9 \cdot \dots \cdot (2n+3)}{1 \cdot 4 \cdot 7 \cdot \dots \cdot (3n-2)}$. |

4.2. FUNKSIONAL QATORLAR

Funksional qatorlarning yaqinlashishi. Tekis yaqinlashuvchi qatorlar. Darajali qatorlar. Funksiyalarni darajali qatorga yoyish. Qatorlarning taqribiy hisoblashlarga tatbiqi

4.2.1. $X \in R$ to'plamda $u_1(x), u_2(x), \dots, u_n(x), \dots$ funksiyalar aniqlangan bo'lsin. Bu funksiyalardan tuzilgan ketma-ketlik X to'plamda berilgan *funksional ketma-ketlik* deyiladi va $\{u_n(x)\}$ bilan belgilanadi.

☐ $X \in R$ to'plamda berilgan $\{u_n(x)\}$ funksional ketma-ketlik hadlaridan tashkil topgan $\sum_{n=1}^{\infty} u_n(x)$ ifodaga *funksional qator* deyiladi. Bunda $u_1(x), u_2(x), \dots, u_n(x), \dots$ – *funksional qatorning hadlari*, $u_n(x)$ – funksional qatorning *umumiy hadi* deb ataladi.

Agar $\sum_{n=1}^{\infty} u_n(x)$ qatorda x ning o'rniga ixtiyoriy $x_0 \in X$ qiymat qo'yish natijasida hosil qilingan $\sum_{n=1}^{\infty} u_n(x_0)$ sonli qator yaqinlashuvchi (uzoqlashuvchi) bo'lsa $\sum_{n=1}^{\infty} u_n(x)$ funksional qatorga x_0 nuqtada *yaqinlashuvchi (uzoqlashuvchi)* deyiladi. Bunda x_0 nuqta $\sum_{n=1}^{\infty} u_n(x)$ funksional qatorning *yaqinlashish (uzoqlashish) nuqtasi* deb ataladi.

☐ $\sum_{n=1}^{\infty} u_n(x)$ funksional qatorning barcha yaqinlashish nuqtalaridan iborat bo'lgan $X_0 (X_0 \subset X)$ to'plamga funksional qatorning *yaqinlashish sohasi* deyiladi.

☐ Agar $\sum_{n=1}^{\infty} u_n(x)$ qator hadlarining absolut qiymatlaridan tashkil topgan $\sum_{n=1}^{\infty} |u_n(x)|$ qator yaqinlashuvchi bo'lsa, $\sum_{n=1}^{\infty} u_n(x)$ qatorga *absolut yaqinlashuvchi qator* deyiladi.

⇒ Ayrim funksional qatorlarning yaqinlashish sohasi musbat hadli qatorlar yaqinlashishining yetarli alomatlari bilan topiladi.

1-misol. Funksional qatorlarning yaqinlashish sohasini toping:

$$1) \sum_{n=1}^{\infty} \frac{1}{n^{\lg x}}; \quad 2) \sum_{n=1}^{\infty} \frac{n^n}{(1+x^2)^n}.$$

☞ 1) $\sum_{n=1}^{\infty} \frac{1}{n^\alpha}$ umumlashgan garmonik qator $\alpha > 1$ da yaqinlashadi $\alpha \leq 1$ da uzoqlashadi. $\alpha = \lg x$ desak umumlashgan garmonik qatordan berilgan qator kelib chiqadi. Bu qator $\lg x > 1$ da, ya'ni $x > 10$ da yaqinlashadi va $\lg x \leq 1$ da, ya'ni $0 < x \leq 10$ da uzoqlashadi. Demak, berilgan qatorning yaqinlashish sohasi $(10; +\infty)$ dan iborat.

2) Berilgan qatorning hadlari $-\infty < x < +\infty$ da aniqlangan va uzluksiz. Koshining ildiz alomati bilan topamiz:

$$l = \lim_{n \rightarrow \infty} \sqrt[n]{\frac{n^n}{(1+x^2)^n}} = \lim_{n \rightarrow \infty} \frac{n}{1+x^2} = +\infty, \quad \forall x \in (-\infty; +\infty).$$

Demak, qator $-\infty < x < +\infty$ da uzoqlashadi. ☞

☐ **4.2.2.** Ixtiyoriy $\varepsilon > 0$ son uchun shunday $n_0(\varepsilon)$ nomer topilsaki, $n > n_0$ bo'lganda barcha $x \in [a; b]$ da yaqinlashuvchi $\sum_{n=1}^{\infty} u_n(x)$ qator uchun $|R_n(x)| < \varepsilon$ tengsizlik bajarilsa, bu qatorga $[a; b]$ kesmada *tekis yaqinlashuvchi qator* deyiladi.

1-teorema (Veyershtrass alomati). Agar $\sum_{n=1}^{\infty} u_n(x)$ funksional qator uchun shunday musbat hadli yaqinlashuvchi $\sum_{n=1}^{\infty} a_n$ sonli qator topilsaki, barcha $x \in [a; b]$ da $|u_n(x)| \leq a_n, n = 1, 2, \dots$ tengsizlik bajarilsa, u holda $\sum_{n=1}^{\infty} u_n(x)$ qator

$[a; b]$ kesmada absolut va tekis yaqinlashadi.

$\sum_{n=1}^{\infty} a_n$ qatorga $\sum_{n=1}^{\infty} u_n(x)$ qator uchun majorant qator deyiladi.

2-misol. Qatorlarning tekis yaqinlashish sohasini toping:

$$1) \sum_{n=1}^{\infty} (-1)^{n-1} \frac{1}{x^{2n} + n}; \quad 2) \sum_{n=1}^{\infty} \frac{\cos nx}{n^2 + \sqrt{(1-x^2)^n}}.$$

☞ 1) Berilgan qator $x \in (-\infty; +\infty)$ nuqtalarda Leybnits alomatiga ko'ra yaqinlashadi:

$$1) \frac{1}{x^2 + 1} > \frac{1}{x^4 + 2} > \frac{1}{x^6 + 3} > \dots > \frac{1}{x^{2n} + n} > \dots, \quad 2) \lim_{n \rightarrow \infty} \frac{1}{x^{2n} + n} = 0.$$

U holda qatorning qoldig'i $|R_n(x)| < |u_{n+1}(x)|$ tengsizlik bilan baholanadi.

Bundan

$$|R_n(x)| < \left| \frac{1}{x^{2n+2} + n + 1} \right| < \frac{1}{n + 1}.$$

$\frac{1}{n + 1} \leq \varepsilon$ tengsizlikdan $n \geq \frac{1}{\varepsilon} - 1$ kelib chiqadi. U holda $n \geq N$ dan boshlab

$|R_n(x)| \leq \varepsilon$ bo'ladi, bu yerda $N = \frac{1}{\varepsilon} - 1$.

Demak, berilgan qator $x \in (-\infty; +\infty)$ da tekis yaqinlashadi.

2) Qatorning hadlari $[-1; 1]$ kesmada aniqlangan va uzluksiz.

Ixtiyoriy n natural son uchun

$$|u_n(x)| = \left| \frac{\cos nx}{n^2 + \sqrt{(1-x^2)^n}} \right| \leq \frac{1}{n^2 + \sqrt{(1-x^2)^n}} \leq \frac{1}{n^2} = a_n$$

tengsizlik bajariladi.

$\sum_{n=1}^{\infty} \frac{1}{n^2}$ sonli qator yaqinlashuvchi. U holda Veershtress alomatiga ko'ra

berilgan qator $[-1; 1]$ kesmada tekis yaqinlashadi. ☞

📌 **4.2.3.** Ushbu $\sum_{n=0}^{\infty} a_n (x - x_0)^n$ ko'rinishdagi funksional qatorga *darajali qator* deyiladi. Bunda $a_0, a_1, \dots, a_n, \dots$ – o'zgarmas sonlar darajali qatorning *koefitsiyentlari*, x_0 – darajali qatorning *markazi* deb ataladi.

Xususan, $x_0 = 0$ bo'lganda $\sum_{n=0}^{\infty} a_n x^n$ darajali qator hosil bo'ladi. Bu qator da $a_n x^n$ had $(n + 1)$ o'rinda turgan bo'lsa ham qulaylik uchun uni n – had deb qaraladi.

2-teorema (Abel teoremasi). Agar $\sum_{n=0}^{\infty} a_n x^n$ darajali qator $x = x_0 \neq 0$ nuqtada yaqinlashsa, u holda u x ning $|x| < |x_0|$ tengsizlikni qanoatlantiruvchi barcha nuqtalarida absolut yaqinlashadi.

1-natija. Agar $\sum_{n=0}^{\infty} a_n x^n$ darajali qator $x = x_1$ nuqtada uzoqlashsa, u holda u x ning $|x| > |x_0|$ tengsizlikni qanoatlantiruvchi barcha nuqtalarida uzoqlashadi.

☑ Agar $\sum_{n=0}^{\infty} a_n x^n$ darajali qator $\{ |x| < R \}$ da absolut yaqinlashsa va $\{ |x| > R \}$ da uzoqlashsa $R \geq 0$ soniga darajali qatorning *yaqinlashish radiusi*, $(-R; R)$ oraliqqa darajali qatorning *yaqinlashish intervali (sohasi)* deyiladi.

Darajali qator yaqinlashish intervalining chegaraviy $x = \pm R$ nuqtalarida yaqinlashishi ham uzoqlashishi ham mumkin. Shu sababli darajali qator bu nuqtalarda alohida tekshiriladi.

Agar $\sum_{n=0}^{\infty} a_n x^n$ darajali qatorning barcha $a_0, a_1, a_2, \dots, a_n, \dots$ koeffitsiyentlari nolga teng bo'lmasa, uning yaqinlashish radiusi quyidagi formulalardan biri bilan topiladi:

$$R = \lim_{n \rightarrow \infty} \left| \frac{a_n}{a_{n+1}} \right|, \quad R = \lim_{n \rightarrow \infty} \frac{1}{\sqrt[n]{|a_n|}}.$$

$\sum_{n=0}^{\infty} a_n x^{np}$ darajali qatorning yaqinlashish radiusi

$$R = \sqrt[p]{\lim_{n \rightarrow \infty} \left| \frac{a_n}{a_{n+1}} \right|}, \quad R = \sqrt[p]{\lim_{n \rightarrow \infty} \frac{1}{\sqrt[n]{|a_n|}}}$$

formulalardan biri bilan topiladi.

$\sum_{n=0}^{\infty} a_n x^n$ qatorning yaqinlashish oralig'i markazi $x_0 \neq 0$ nuqtada bo'lgan $(x_0 - R; x_0 + R)$ intervaldan iborat bo'ladi.

3-misol. Darajali qatorlarning yaqinlashish sohasini toping:

- | | |
|---|--|
| 1) $\sum_{n=1}^{\infty} \frac{x^n}{n!};$ | 2) $\sum_{n=1}^{\infty} \left(1 + \frac{1}{n}\right)^{n^2} x^n;$ |
| 3) $\sum_{n=1}^{\infty} \frac{(x-2)^n}{n^2};$ | 4) $\sum_{n=1}^{\infty} \frac{(x-1)^{2n}}{n \cdot 9^n}.$ |

☞ 1) Berilgan qatorda $a_n = \frac{1}{n!}, \quad a_{n+1} = \frac{1}{(n+1)!} = \frac{1}{n!(n+1)}.$

U holda

$$R = \lim_{n \rightarrow \infty} \left| \frac{a_n}{a_{n+1}} \right| = \lim_{n \rightarrow \infty} \left| \frac{n!(n+1)}{n!} \right| = \infty.$$

Demak, qator $x \in (-\infty, +\infty)$ da yaqinlashadi.

2) Berilgan qator uchun $a_n = \left(1 + \frac{1}{n}\right)^{n^2}$.

Bundan

$$R = \lim_{n \rightarrow \infty} \frac{1}{\sqrt[n]{\left(1 + \frac{1}{n}\right)^{n^2}}} = \frac{1}{\lim_{n \rightarrow \infty} \left(1 + \frac{1}{n}\right)^n} = \frac{1}{e}.$$

$x = -\frac{1}{e}$ da qator $\sum_{n=1}^{\infty} (-1)^n \frac{1}{e^n} \left(1 + \frac{1}{n}\right)^{n^2}$ ko'rinishni oladi. Bu qator uchun

Leybnits alomatining ikkinchi sharti bajarilmaydi:

$$\lim_{n \rightarrow \infty} \frac{1}{e^n} \left(1 + \frac{1}{n}\right)^{n^2} = 1 \neq 0.$$

Shu sababli $\sum_{n=1}^{\infty} (-1)^n \frac{1}{e^n} \left(1 + \frac{1}{n}\right)^{n^2}$ qator uzoqlashadi va shu kabi $x = \frac{1}{e}$ da qator

uzoqlashadi. Demak, berilgan qator $\left(-\frac{1}{e}; \frac{1}{e}\right)$ oraliqda yaqinlashadi.

3) Berilgan qator uchun $a_n = \frac{1}{n^2}$, $a_{n+1} = \frac{1}{(n+1)^2}$.

Bundan

$$R = \lim_{n \rightarrow \infty} \left| \frac{a_n}{a_{n+1}} \right| = \lim_{n \rightarrow \infty} \frac{(n+1)^2}{n^2} = 1.$$

Demak, qator $(2-1; 2+1)$ ya'ni $(1; 3)$ oraliqda yaqinlashadi.

Intervalning chegaraviy nuqtalarida tekshiramiz.

$x = 1$ da qator $\sum_{n=1}^{\infty} \frac{(-1)^n}{n^2}$ ko'rinishni oladi. Leybnits alomatiga ko'ra

$$1) 1 > \frac{1}{4} > \frac{1}{9} > \dots; \quad 2) \lim_{n \rightarrow \infty} \frac{1}{n^2} = 0.$$

Demak, qator $x = 1$ da yaqinlashadi. $x = 3$ da qator $\sum_{n=1}^{\infty} \frac{1}{n^2}$ ko'rinishini oladi.

Bu qator yaqinlashuvchi.

Shunday qilib, qatorning yaqinlashish sohasi $[1; 3]$ dan iborat.

4) $\sum_{n=1}^{\infty} \frac{(x-1)^{2n}}{n \cdot 9^n}$ qatorning yaqinlashish radiusini topamiz:

$$R = \lim_{n \rightarrow \infty} \sqrt{\left| \frac{a_n}{a_{n+1}} \right|} = \lim_{n \rightarrow \infty} \sqrt{\frac{(n+1) \cdot 9^{n+1}}{n \cdot 9^n}} = 3.$$

Demak, qator $(1-3; 1+3)$ ya'ni $(-2; 4)$ oraliqda yaqinlashadi.

Chetki $x = -2$ va $x = 4$ nuqtalarda berilgan qatordan uzoqlashuvchi garmonik qator kelib chiqadi. Shunday qilib, qatorning yaqinlashish sohasi $(-2; 4)$ dan iborat. \blacktriangleleft

\Rightarrow 1°. Darajali qator yaqinlashish oralig'i ichida yotuvchi har qanday $[-R; R]$ kesmada tekis yaqinlashadi.

2°. Darajali qatorning yig'indisi bu qatorning yaqinlashish oralig'iga tegishli bo'lgan har bir nuqtada uzluksiz bo'ladi.

3°. Darajali qatorni o'zining yaqinlashish oralig'ida hadma-had differensiyallash (integrallash) mumkin. Darajali qatorni hadma-had differensiyallash (integrallash) natijasida hosil qilingan qatorning yaqinlashish oralig'i ham berilgan qatorning yaqinlashish oralig'i bilan bir xil bo'ladi.

4-misol. Qatorlarning yig'indisini toping:

1) $\sum_{n=1}^{\infty} \frac{x^n}{n}$;

2) $\sum_{n=1}^{\infty} nx^n$.

\Rightarrow 1) Berilgan qator uchun $a_n = \frac{1}{n}$, $a_{n+1} = \frac{1}{n+1}$. Bundan

$$R = \lim_{n \rightarrow \infty} \left| \frac{a_n}{a_{n+1}} \right| = \frac{n+1}{n} = 1.$$

Qatorni $|x| < 1$ da hadma-had differensiyalaymiz:

$$1 + x + x^2 + \dots + x^{n-1} + \dots = \frac{1}{1-x}.$$

Bu qatorni va uning yig'indisini $|x| < 1$ da hadma-had integrallaymiz:

$$S(x) = \int dx + \int x dx + \int x^2 dx + \dots + \int x^{n-1} dx + \dots = \int \frac{dx}{1-x} = -\ln|1-x|.$$

Demak, qatorning yig'indisi $S(x) = -\ln|1-x|$ ($|x| < 1$) ga teng.

2) Bu qator uchun $a_n = n$, $a_{n+1} = n+1$ va

$$R = \lim_{n \rightarrow \infty} \left| \frac{a_n}{a_{n+1}} \right| = \frac{n}{n+1} = 1.$$

Qatorni

$$x \sum_{n=1}^{\infty} nx^{n-1} = x(1 + 2x + 3x^2 + \dots + nx^{n-1} + \dots)$$

ko‘rinishda yozib olamiz.

$\sum_{n=1}^{\infty} nx^{n-1} = 1 + 2x + 3x^2 + \dots + nx^{n-1} + \dots$ qatorni $|x| < 1$ da hadma-had integrallaymiz:

$$x + x^2 + x^3 \dots + x^n + \dots = \frac{x}{1-x}.$$

Bu qatorni va uning yig‘indisini $|x| < 1$ da hadma-had differensiallaymiz:

$$S_1(x) = (1 + 2x + 3x^2 + \dots + nx^{n-1} + \dots) = \frac{1}{(1-x)^2}.$$

Demak, $\sum_{n=1}^{\infty} nx^n$ qatorning yig‘indisi

$$S(x) = xS_1(x) = \frac{x}{(1-x)^2} \quad (|x| < 1). \quad \odot$$

4.2.4. x_0 nuqtada cheksiz differensiyallanuvchi $f(x)$ funksiya uchun tuzilgan

$$f(x) = \sum_{n=0}^{\infty} \frac{f^{(k)}(x_0)}{k!} (x - x_0)^k + \frac{f^{(n+1)}(c)}{(n+1)!} (x - x_0)^{n+1}, \quad c \in (x_0; x)$$

qatorga *Taylor qatori* (Lagranj ko‘rinishidagi qoldiq hadli) deyiladi.

5-misol. $f(x) = x^4 - 3x^3 + 2x^2 - 1$ funksiyaning $x_0 = 2$ nuqta atrofida Taylor qatoriga yoying.

\odot Funksiya va funksiya hosilalarining $x_0 = 2$ nuqtadagi qiymatlarini topamiz:

$$f(x) = x^4 - 3x^3 + 2x^2 - 1, \quad f(2) = -1;$$

$$f'(x) = 4x^3 - 9x^2 + 4x, \quad f'(2) = 4;$$

$$f''(x) = 12x^2 - 18x + 4, \quad f''(2) = 16;$$

$$f'''(x) = 24x - 18, \quad f'''(2) = 30;$$

$$f^{IV}(x) = 24, \quad f^{IV}(2) = 24.$$

Topilgan qiymatlarni Taylor formulasiga qo‘yamiz:

$$f(x) = -1 + 4(x-2) + \frac{16}{2!}(x-2)^2 + \frac{30}{3!}(x-2)^3 + \frac{24}{4!}(x-2)^4$$

yoki

$$f(x) = -1 + 4(x-2) + 8(x-2)^2 + 5(x-2)^3 + (x-2)^4. \quad \odot$$

⇒ $x_0 = 0$ da Teylor qatoridan kelib chiqadigan

$$f(x) = \sum_{k=0}^n \frac{f^{(k)}(0)}{k!} x^k + \frac{f^{(n+1)}(c)}{(n+1)!} x^{n+1} \quad c \in (x_0; x)$$

qatorga *Makloren qatori* (Makloren formulasi) deyiladi.

Asosiy elementar funksiyalarning Makloren qatoriga quyidagicha yoyiladi:

$$1. e^x = \sum_{n=0}^{\infty} \frac{x^n}{n!} = 1 + x + \frac{x^2}{2!} + \frac{x^3}{3!} + \dots + \frac{x^n}{n!} + \dots, \quad -\infty < x < +\infty;$$

$$2. \sin x = \sum_{n=0}^{\infty} \frac{(-1)^n x^{2n+1}}{(2n+1)!} = x - \frac{x^3}{3!} + \frac{x^5}{5!} + \dots + \frac{(-1)^n x^{2n+1}}{(2n+1)!} + \dots, \quad -\infty < x < +\infty;$$

$$3. \cos x = \sum_{n=0}^{\infty} \frac{(-1)^n x^{2n}}{(2n)!} = 1 - \frac{x^2}{2!} + \frac{x^4}{4!} + \dots + \frac{(-1)^n x^{2n}}{(2n)!} + \dots, \quad -\infty < x < +\infty;$$

$$4. \ln(1+x) = \sum_{n=0}^{\infty} \frac{(-1)^n x^{n+1}}{n+1} = x - \frac{x^2}{2} + \frac{x^3}{3} + \dots + \frac{(-1)^{n-1} x^n}{n} + \dots, \quad -1 < x < 1;$$

$$5. (1+x)^\alpha = 1 + \sum_{n=1}^{\infty} \frac{\alpha(\alpha-1)\dots(\alpha-n+1)}{n!} x^n =$$

$$= 1 + \alpha x + \frac{\alpha(\alpha-1)}{2!} x^2 + \dots + \frac{\alpha(\alpha-1)\dots(\alpha-n+1)}{n!} x^n + \dots, \quad -1 < x < 1;$$

$$6. \arctg x = \sum_{n=0}^{\infty} \frac{(-1)^n x^{2n+1}}{2n+1} = x - \frac{x^3}{3} + \frac{x^5}{5} + \dots + \frac{(-1)^n x^{2n+1}}{2n+1} + \dots, \quad -1 < x < 1.$$

6-misol. Funksiyalarni x ning darajalari bo'yicha qatorga yoying:

$$1) f(x) = \frac{2}{(x-3)^2};$$

$$2) f(x) = \sin^2 x.$$

⇒ 1) $\frac{2}{(x-3)^2} = -\left(\frac{2}{x-3}\right)'$ bo'lishini hisobga olib, avval

$$\frac{2}{x-3} = -\frac{2}{3} \cdot \frac{1}{1-\frac{x}{3}}$$

funksiyani x ning darajalari bo'yicha qatorga yoyish masalasini qaraymiz.

$(1+x)^\alpha$ funksiyaning Makloren qatoriga yoyilmasidan $\alpha = -1$ da topamiz:

$$\frac{1}{1+x} = 1 - x + x^2 + \dots + (-1)^n x^n + \dots, \quad |x| < 1.$$

Bu formula bilan topamiz:

$$\frac{2}{x-3} = -\frac{2}{3} \cdot \frac{1}{1-\frac{x}{3}} = -\frac{2}{3} \cdot \left(1 + \frac{x}{3} + \frac{x^2}{3^2} + \dots + \frac{x^n}{3^n} + \dots\right), \quad \left|\frac{x}{3}\right| < 1$$

Bu qatorni yaqinlashish sohasida hadma-had differensiallaymiz.

$$\left(\frac{2}{x-3}\right)' = -\frac{2}{3} \cdot \left(\frac{1}{3} + \frac{2x}{3^2} + \dots + \frac{nx^{n-1}}{3^n} + \dots\right), \quad \left|\frac{x}{3}\right| < 1.$$

Bundan

$$\frac{2}{(x-3)^2} = \frac{2}{3} \cdot \left(\frac{1}{3} + \frac{2x}{3^2} + \dots + \frac{nx^{n-1}}{3^n} + \dots\right) = \frac{2}{3} \sum_{n=0}^{\infty} \frac{(n+1)x^n}{3^{n+1}}, \quad \left|\frac{x}{3}\right| < 1.$$

2) Berilgan funksiyaning x ning darajalari bo'yicha yoyilmasini

$$\sin^2 x = \frac{1}{2}(1 - \cos 2x)$$

almashtirishga $\cos 2x$ funksiyaning Makloren qatoriga yoyilmasini qo'yish orqali topamiz. $\cos 2x$ funksiyaning x ning darajalari bo'yicha yoyilmasini $\cos x$ funksiyaning Makloren qatoriga yoyilmasida x ni $2x$ bilan almashtirib, topamiz:

$$\cos 2x = 1 - \frac{2^2 x^2}{2!} + \frac{2^4 x^4}{4!} - \dots + (-1)^n \frac{2^{2n} x^{2n}}{(2n)!} + \dots, \quad -\infty < x < +\infty.$$

Bundan

$$\sin^2 x = \frac{1}{2} - \frac{1}{2} \left(1 - \frac{2^2 x^2}{2!} + \frac{2^4 x^4}{4!} - \dots + (-1)^n \frac{2^{2n} x^{2n}}{(2n)!} + \dots\right)$$

yoki

$$\sin^2 x = \frac{2x^2}{2!} - \frac{2^3 x^4}{4!} - \dots + (-1)^{n+1} \frac{2^{2n-1} x^{2n}}{(2n)!} + \dots, \quad -\infty < x < +\infty. \quad \odot$$

4.2.5. *Funksiyalar qiymatini taqribiy hisoblash*

$f(x)$ funksiyaning $x = x_0$ qiymatini berilgan aniqlikda hisoblash talab qilingan bo'lsin. Bu funksiya $(-R; R)$ oraliqda darajali qatorga yoyilsin va $x_0 \in (-R; R)$ bo'lsin.

U holda $f(x)$ funksiyaning x_0 nuqtadagi aniq qiymati Teylor qatori bilan taqribiy qiymati esa shu qatorning n -qismaniy yig'indisi bilan hisoblanishi mumkin, ya'ni $f(x_0) \approx S_n(x_0)$. Bu tenglikning aniqligi n ning ortishi bilan ortib boradi. Bu tenglikning absolut xatosi $|R_n(x_0)| = |f(x_0) - S_n(x_0)|$ ga teng bo'ladi.

Agar $f(x_0)$ qiymatni $\varepsilon > 0$ aniqlikda hisoblash talab qilinsa, shunday dastlabki hadlar yig'indisini olish kerak bo'ladiki, bunda $|R_n(x_0)| < \varepsilon$ bo'lishi lozim.

Musbat hadli qatorning qoldig'i $R_n < \int_n^{\infty} f(x)dx$ tengsizlik bilan, ishora almashinuvchi qatorning qoldig'i $|R_n| < |a_{n+1}|$ tengsizlik bilan baholanadi. Bundan tashqari qator qoldig'i $|R_n(x_0)| = \left| \frac{f^{(n+1)}(c)}{(n+1)!} (x_0 - c)^{n+1} \right| < \varepsilon$ tengsizlik bilan ham baholanishi mumkin.

7-misol. e sonini $\varepsilon = 0,001$ aniqlikda hisoblang.

☉ e^x funksiyaning Makloren qatoriga yoyilmasidan foydalanamiz:

$$x = 1 \text{ da } e = 1 + 1 + \frac{1}{2!} + \frac{1}{3!} + \dots + \frac{1}{n!} + \dots$$

Bunda $R_n(1) = \frac{e^c}{(n+1)!}$, $c \in (0;1)$ yoki $e^c < e^1 < 3$ bo'lishi hisobga olinsa,

$$R_n(1) < \frac{3}{(n+1)!} \text{ kelib chiqadi.}$$

$$n = 6 \text{ da } R_6(1) = \frac{3}{7!} = 0,00069 < 0,001.$$

Demak,

$$e \approx 1 + 1 + \frac{1}{2!} + \frac{1}{3!} + \frac{1}{4!} + \frac{1}{5!} + \frac{1}{6!} \approx 2,718. \quad \text{☉}$$

8-misol. $\cos 18^\circ$ ni 0,0001 aniqlikda hisoblang.

☉ Argumentni radian o'lchamiga o'tkazamiz va topilgan sonni $\cos x$ funksiyaning Makloren qatoriga qo'yamiz:

$$\cos 18^\circ = \cos \frac{\pi}{10} = 1 - \frac{1}{2!} \left(\frac{\pi}{10} \right)^2 + \frac{1}{4!} \left(\frac{\pi}{10} \right)^4 + \dots, \text{ bunda } \frac{\pi}{10} = 0,31416,$$

$$\left(\frac{\pi}{10} \right)^2 = 0,09870, \quad \left(\frac{\pi}{10} \right)^4 = 0,00974.$$

Qator ishora almashinuvchi.

Shu sababli

$$a_{n+1} = a_4 = \frac{1}{6!} \left(\frac{\pi}{10} \right)^6 < 0,0001 \text{ va } R_n < |a_3|.$$

Demak,

$$\cos 18^\circ \approx 1 - \frac{0,09870}{2} + \frac{0,00974}{24} \approx 0,9511. \quad \text{☉}$$

Aniq integrallarni taqribiy hisoblash

$\int_a^b f(x)dx$ integralni $\varepsilon > 0$ aniqlikda hisoblash talab qilingan bo'lsin.

Integral ostidagi funksiyani $[a; b]$ kesmani o'z ichiga olgan $(-R; R)$ oraliqda darajali qatorga yoyish mumkin bo'lsin. U holda berilgan integral qatorni hadma-had integrallash bilan integrallanadi. Integrallashning aniqligi funksiya qiymatini taqribiy hisoblashdagi kabi baholanadi.

9-misol. $\int_0^x \frac{\arctg x}{x} dx$ integralni toping.

☞ $\arctg x$ funksiyaning qatorga yoyilmasidan integral ostiga qo'yamiz va 0 dan x gacha integrallaymiz:

$$\begin{aligned} \int_0^x \frac{\arctg x}{x} dx &= \int_0^x \left(1 - \frac{x^2}{3} + \frac{x^4}{5} - \dots + (-1)^{n-1} \frac{x^{2n-2}}{2n-1} + \dots \right) dx = \\ &= x - \frac{x^3}{3^2} + \frac{x^5}{5^2} - \dots + (-1)^{n-1} \frac{x^{2n-1}}{(2n-1)^2} + \dots \end{aligned}$$

Dalamber alomatiga ko'ra $R = \lim_{n \rightarrow \infty} \left| \frac{(2n-1)^2}{(2n+1)^2} \right| = 1$.

Intervalning chegaraviy nuqtalarida tekshiramiz.

$x = 1$ da qator $\sum_{n=1}^{\infty} \frac{(-1)^{n-1}}{(2n-1)^2}$ va $x = -1$ da qator $\sum_{n=1}^{\infty} \frac{(-1)^n}{(2n-1)^2}$ bo'ladi.

Bu qatorlar Leybnits alomatiga ko'ra yaqinlashuvchi.

Demak, qatorning yaqinlashish sohasi $[-1; 1]$ dan iborat. ☞

10-misol. $\int_0^{0,1} \frac{\ln(1+x)}{x} dx$ integralni 0,0001 aniqlikda hisoblang.

$$\begin{aligned} \text{☞ } \int_0^{0,1} \frac{\ln(1+x)}{x} dx &= \int_0^{0,1} \frac{1}{x} \left[\sum_{n=0}^{\infty} (-1)^n \frac{x^{n+1}}{n+1} \right] dx = \\ &= \sum_{n=0}^{\infty} (-1)^n \int_0^{0,1} \frac{x^n}{n+1} dx = \sum_{n=0}^{\infty} (-1)^n \frac{x^{n+1}}{(n+1)^2} \Big|_0^{0,1} = \frac{1}{10} - \frac{1}{2^2 \cdot 100} + \frac{1}{3^2 \cdot 1000} \approx 0,0076 \quad \text{☞} \end{aligned}$$

Differensiyal tenglamalarni taqribiy yechish

Aytaylik, $y' = f(x, y)$ differensial tenglamaning $y(x_0) = y_0$ boshlang'ich shartini qanoatlantiruvchi yechimini topish talab qilingan bo'lsin.

Bu tenglamaning yechimini $y = \sum_{n=0}^{\infty} \frac{y^{(n)}(x_0)}{n!} (x - x_0)^n$ ko'rinishida izlanadi.

Bu yerda $y(x_0) = y_0$, $y'(x_0) = f(x_0, y_0)$ bo'ladi. $y''(x_0)$ va boshqa hosilalar berilgan tenglamani ketma-ket differensiallashtirish hamda x, y', y'', \dots qiymatlar o'rniga x_0, y'_0, y''_0, \dots qiymatlarni qo'yish orqali topiladi.

Yuqori tartibli differensial tenglamalarni Teylor qatori yordamida yechish shu kabi bajariladi. Differensial tenglamalarni taqribiy yechishning bu usuliga *ketma-ket differensiallashtirish* usuli deyiladi.

11-misol. $y'' = x + y^2$, $y(0) = 0$, $y'(0) = 1$ tenglama yechimi yoyilmasining dastlabki to'rtta noldan farqli hadini toping.

$$\odot \quad y''(0) = 0 + 0 = 0, \quad y'''(0) = (1 + 2yy')|_{x=0} = 1 + 2 \cdot 0 \cdot 1 = 1,$$

$$y^{IV}(0) = (2y'^2 + 2yy'')|_{x=0} = 2 \cdot 1 + 2 \cdot 0 \cdot 0 = 2,$$

$$y^V(0) = (6y'y'' + 2yy''')|_{x=0} = 6 \cdot 1 \cdot 0 + 2 \cdot 0 \cdot 1 = 0,$$

$$y^{VI}(0) = (8y'y''' + 6y''^2 + 2yy^{IV})|_{x=0} = 8 \cdot 1 \cdot 1 + 6 \cdot 0^2 + 2 \cdot 0 \cdot 2 = 8.$$

Demak, izlanayotgan yechim

$$y = \frac{x}{1!} + \frac{x^3}{3!} + \frac{2x^4}{4!} + \frac{8x^6}{6!} \quad \text{yoki} \quad y = x + \frac{1}{6}x^3 + \frac{1}{12}x^4 + \frac{1}{90}x^6. \quad \odot$$

Differensial tenglamalarni taqribiy yechishning yana bir usuli *noma'lum ko'effitsiyentlar* usuli deb ataladi.

Aytaylik,

$$y'' + p(x)y' + q(x)y = f(x)$$

differensial tenglamaning $y(x_0) = y_0$, $y'(x_0) = y'_0$ boshlang'ich shartlarni qanoatlantiruvchi yechimini topish talab qilingan bo'lsin.

$p(x), q(x)$ va $f(x)$ funksiyalar biror $(x_0 - R; x_0 + R)$ oraliqda $x - x_0$ ning darajalari bo'yicha qatorga yoyiladi deb faraz qilib, tenglamaning yechimi

$y = \sum_{n=0}^{\infty} c_n (x - x_0)^n$ ko'rinishida izlanadi. Bu yerda c_0, c_1, c_2, \dots — noma'lum ko'effitsiyentlar.

c_0 va c_1 ko'effitsiyentlar boshlang'ich shartlardan topiladi: $c_0 = y_0, c_1 = y'_0$.

Keyingi ko'effitsiyentlarni topish uchun $y = \sum_{n=0}^{\infty} c_n (x - x_0)^n$ tenglama ikki marta differensiallashtiriladi, y va uning differentsiallari $y'' + p(x)y' + q(x)y = f(x)$ tenglamaga qo'yiladi, $p(x), q(x)$ va $f(x)$ funksiyalar yoyilmalari bilan almashtiriladi. Natijada ayniyat kelib chiqadi. Bu ayniyatdan qolgan

koeffitsiyentlar topiladi. Hosil qilingan $y = \sum_{n=0}^{\infty} c_n (x - x_0)^n$ qator ($x_0 - R; x_0 + R$) oraliqda yaqinlashadi va $y'' + p(x)y' + q(x)y = f(x)$ tenglamaning yechimi bo'ladi.

12-misol. $y'' + xy' + y = x \cos x$, $y(0) = 0$, $y'(0) = 1$ tenglamani noma'lum koeffitsiyentlar usuli bilan yeching.

☞ Tenglama koeffitsiyentlarini darajali qatorga yoyamiz:

$$p(x) = x, \quad q(x) = 1, \quad f(x) = x \cos x = x \left(1 - \frac{x^2}{2!} + \frac{x^4}{4!} - \dots \right).$$

Tenglamaning yechimini

$$y = c_0 + c_1 x + c_2 x^2 + c_3 x^3 + \dots$$

ko'rinishda izlaymiz.

U holda

$$y' = c_1 + 2c_2 x + 3c_3 x^2 + 4c_4 x^3 + \dots,$$

$$y'' = 2c_2 + 2 \cdot 3c_3 x + 3 \cdot 4c_4 x^2 + \dots$$

Boshlang'ich shartlardan topamiz: $c_0 = 0$, $c_1 = 1$.

Topilgan qatorlarni differensial tenglamaga qo'yamiz:

$$(2c_2 + 2 \cdot 3c_3 x + 3 \cdot 4c_4 x^2 + \dots) + x(1 + 2c_2 x + 3c_3 x^2 + 4c_4 x^3 + \dots) + (x + c_2 x^2 + c_3 x^3 + \dots) = x \left(1 - \frac{x^2}{2!} + \frac{x^4}{4!} - \frac{x^6}{6!} + \dots \right).$$

x ning bir xil darajalari oldidagi koeffitsiyentlarni tenglashtiramiz:

$$x^0 : 2c_2 = 0,$$

$$x^1 : 2 \cdot 3c_3 + 2 = 1,$$

$$x^2 : 3 \cdot 4c_4 + 3c_2 = 0,$$

$$x^3 : 4 \cdot 5c_5 + 4c_3 = -\frac{1}{2},$$

$$x^4 : 5 \cdot 6c_6 + 5c_4 = 0,$$

.....

Bundan $c_2 = c_4 = c_6 = \dots = 0$, $c_3 = -\frac{1}{3!}$, $c_5 = \frac{1}{5!}$, $c_7 = -\frac{1}{7!}$.

Demak, izlanayotgan yechim

$$y = x - \frac{x^3}{3!} + \frac{x^5}{5!} - \frac{x^7}{7!} + \dots$$

ya'ni

$$y = \sin x. \quad \text{☞}$$

Mashqlar

4.2.1. Funksional qatorlarning yaqinlashish sohasini toping:

- 1) $\sum_{n=1}^{\infty} \frac{1}{1+x^{2n}}$;
- 2) $\sum_{n=1}^{\infty} (-1)^{n-1} n e^{nx}$;
- 3) $\sum_{n=1}^{\infty} \frac{(8x^2+1)^n}{3^n}$;
- 4) $\sum_{n=1}^{\infty} \lg^n(x-2)$;
- 5) $\sum_{n=1}^{\infty} 2^n \sin\left(\frac{x}{3^n}\right)$;
- 6) $\sum_{n=1}^{\infty} \frac{1}{n^{\ln x}}$.

4.2.2. Qatorlarning tekis yaqinlashish sohasini toping:

- 1) $\sum_{n=1}^{\infty} (-1)^n \frac{n}{x^4+n^2}$;
- 2) $\sum_{n=1}^{\infty} (-1)^n \frac{1}{\sqrt{4-x^2+n^2}}$;
- 3) $\sum_{n=1}^{\infty} \frac{\cos nx}{n^2}$;
- 4) $\sum_{n=1}^{\infty} \frac{\sin nx}{\sqrt{9-x^2+n^2}}$;
- 5) $\sum_{n=1}^{\infty} \frac{\sin nx}{2^{n-1}}$;
- 6) $\sum_{n=1}^{\infty} \operatorname{arctg}\left(\frac{x}{n\sqrt{n}}\right)$.

4.2.3. Darajali qatorning yaqinlashish sohasini toping:

- 1) $\sum_{n=0}^{\infty} \frac{x^n}{3^n(n+1)}$;
- 2) $\sum_{n=1}^{\infty} \frac{2^n x^n}{\sqrt{n}}$;
- 3) $\sum_{n=1}^{\infty} \frac{x^n}{n \cdot 2^n}$;
- 4) $\sum_{n=1}^{\infty} \frac{2^n x^n}{\sqrt{3^n}}$;
- 5) $\sum_{n=1}^{\infty} \frac{n! x^n}{(n+1)^n}$;
- 6) $\sum_{n=1}^{\infty} \frac{(-1)^n}{n!} \left(\frac{n}{e}\right)^n x^n$;
- 7) $\sum_{n=0}^{\infty} \frac{(-1)^{n-1} (x+2)^n}{n^3+3}$;
- 8) $\sum_{n=0}^{\infty} \frac{(-1)^n (x+4)^n}{(3n+2) \cdot 2^n}$;
- 9) $\sum_{n=1}^{\infty} \frac{x^{2n}}{n \cdot 10^n}$;
- 10) $\sum_{n=1}^{\infty} \frac{x^{3n}}{8^n(n^2+1)}$;
- 11) $\sum_{n=1}^{\infty} \frac{(x+2)^{2n}}{n^2 \cdot 3^n}$;
- 12) $\sum_{n=1}^{\infty} \frac{(3x)^{5n}}{2n-1}$;
- 13) $\sum_{n=1}^{\infty} \frac{x^n}{\sin^n n}$;
- 14) $\sum_{n=1}^{\infty} (2-x)^n \sin \frac{\pi}{2^n}$.

4.2.4. Qatorlarning yig'indisini toping:

- 1) $\sum_{n=1}^{\infty} \frac{(-1)^{n+1} x^{2n-1}}{2n-1}$;
- 2) $\sum_{n=1}^{\infty} \frac{x^{2n}}{2n}$;
- 3) $\sum_{n=1}^{\infty} n 2^n x^n$;
- 4) $\sum_{n=1}^{\infty} n^2 x^{n-1}$.

4.2.5. $f(x) = x^4 - 4x^3 - 2x + 1$ funksiyani $x_0 = -1$ nuqta atrofida Teylor qatoriga yoying.

4.2.6. $f(x) = x^5 - x^3 + x - 1$ funksiyani $x_0 = 1$ nuqta atrofida Teylor qatoriga yoying.

4.2.7. Funktsiyalarni x ning darajalari bo'yicha qatorga yoying:

- | | |
|---------------------------------|-----------------------------------|
| 1) $f(x) = \frac{3}{4-x}$; | 2) $f(x) = \frac{x}{3+2x}$; |
| 3) $f(x) = \frac{3}{2-x-x^2}$; | 4) $f(x) = \ln(12x^2 + 7x + 1)$; |
| 5) $f(x) = xe^{2x+1}$; | 6) $f(x) = \sin^2 x \cos^2 x$. |

4.2.8. Darajali qatorlar yordamida 0,0001 aniqlikda hisoblang:

- | | |
|-----------------|----------------------|
| 1) $\ln 1,1$; | 2) $\sin 12^\circ$; |
| 3) \sqrt{e} ; | 4) $\sqrt[3]{520}$. |

4.2.9. Darajali qatorlar yordamida integrallarni toping:

- | | |
|---------------------------------------|------------------------------|
| 1) $\int \frac{\sin x dx}{x}$; | 2) $\int \frac{e^x dx}{x}$; |
| 3) $\int_0^x \frac{\ln(1+x)}{x} dx$; | 4) $\int_0^x \cos x^2 dx$. |

4.2.10. Integrallarni 0,0001 aniqlikda hisoblang:

- | | |
|---|---|
| 1) $\int_0^1 \frac{1-\cos x}{x} dx$; | 2) $\int_0^{\frac{1}{4}} e^{-x^2} dx$; |
| 3) $\int_0^{0,2} \frac{\arctg x dx}{x}$; | 4) $\int_0^1 \cos \sqrt{x} dx$. |

4.2.11. Differensial tenglamalar yechimi yoyilmasining dastlabki to'rtta noldan farqli hadini toping:

- | | |
|---|--|
| 1) $y' = x^2 + y^2, y(0) = 1$; | 2) $y' = 2\cos x - xy^2, y(0) = 1$; |
| 3) $y'' = xy' - y + e^x, y(0) = 1, y'(0) = 0$; | 4) $y'' = y \cos x + x, y(0) = 1, y'(0) = 0$. |

4.2.12. Differensial tenglamalarni noma'lum koeffitsiyentlar usuli bilan yeching:

- | | |
|---|---|
| 1) $y'' + xy' + y = 1, y(0) = 0, y'(0) = 0$; | 2) $y'' - xy' + y = x, y(0) = 0, y'(0) = 0$. |
|---|---|

4.3. FURE QATORLARI

Fure qatorining yaqinlashishi. Juft va toq funksiyalarning Fure qatorlari. Davri $2l$ bo'lgan funksiyalarning Fure qatorlari. Nodavriy funksiyalarni Fure qatoriga yoyish

4.3.1. Koeffitsiyentlari

$$a_n = \frac{1}{\pi} \int_{-\pi}^{\pi} f(x) \cos nx dx, \quad (n = 0, 1, 2, \dots), \quad b_n = \frac{1}{\pi} \int_{-\pi}^{\pi} f(x) \sin nx dx, \quad (n = 1, 2, \dots)$$

formulalar bilan aniqlanadigan

$$f(x) = \frac{a_0}{2} + \sum_{n=1}^{\infty} a_n (\cos nx + b_n \sin nx)$$

qatorga davri 2π bo'lgan $f(x)$ funksiyaning $[-\pi; \pi]$ intervaldagi *Fure qatori* deyiladi.

 Agar $f(x)$ funksiya $[a; b]$ kesmada monoton bo'lsa yoki $[a; b]$ kesmani chekli sondagi qisman kesmalarga bo'lish mumkin bo'lsa va bu kesmalarning har birida $f(x)$ funksiya monoton (faqat o'ssa yoki faqat kamaysa) yoki o'zgarmas bo'lsa, $f(x)$ funksiyaga $[a; b]$ kesmada *bo'lakli-monoton* funksiya deyiladi.

 Agar $f(x)$ funksiya $[a; b]$ kesmada chekli sondagi birinchi tur uzilish nuqtalariga ega bo'lsa, $f(x)$ funksiyaga $[a; b]$ kesmada *bo'lakli-uzluksiz* funksiya deyiladi.

Agar $f(x)$ funksiya $[a; b]$ kesmada uzluksiz yoki bo'lakli-uzluksiz bo'lib, bo'lakli-monoton bo'lsa $f(x)$ funksiya $[a; b]$ kesmada *Dirixle shartlarini* qanoatlantiradi deyiladi.

2-teorema (*Dirixle teoremasi*). Davri 2π bo'lgan $f(x)$ funksiya $[-\pi; \pi]$ kesmada Dirixle shartlarini qanoatlantirsa, u holda bu funksiyaning Fure qatori $[-\pi; \pi]$ kesmada yaqinlashadi. Bunda:

1) $f(x)$ funksiya uzluksiz bo'lgan har bir nuqtada qatorning $S(x)$ yig'indisi $f(x)$ funksiyaning shu nuqtadagi qiymati bilan ustma-ust tushadi: $S(x) = f(x)$;

2) Har bir uzilish nuqtasi x_0 da $S(x_0) = \frac{f(x_0 - 0) + f(x_0 + 0)}{2}$ bo'ladi;

3) $x = -\pi$ va $x = \pi$ nuqtalarda $S(-\pi) = S(\pi) = \frac{f(-\pi + 0) + f(\pi - 0)}{2}$ bo'ladi.

1-misol. $(-\pi; \pi]$ intervalda $f(x) = x$ formula bilan berilgan davri 2π bo'lgan funktsiyani Fure qatoriga yoying (1-shakl).

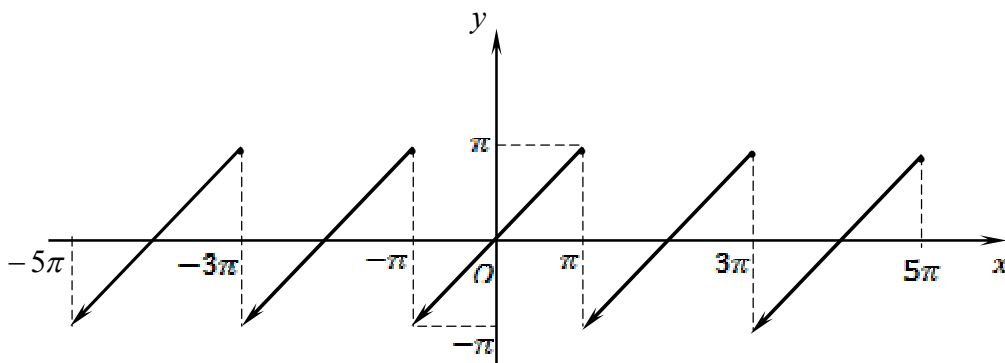

1-shakl.

☞ Bu funktsiya Dirixle shartlarini qanoatlantiradi. Demak, uni Fure qatoriga yoyish mumkin.

Fure koeffitsiyentlarini topamiz:

$$a_0 = \frac{1}{\pi} \int_{-\pi}^{\pi} x dx = \frac{1}{\pi} \left. \frac{x^2}{2} \right|_{-\pi}^{\pi} = 0;$$

$$\begin{aligned} a_n &= \frac{1}{\pi} \int_{-\pi}^{\pi} x \cos nx dx = \frac{1}{\pi} \left(\left. \frac{x \sin nx}{n} \right|_{-\pi}^{\pi} - \frac{1}{n} \int_{-\pi}^{\pi} \sin nx dx \right) = \frac{1}{n^2 \pi} \cos nx \Big|_{-\pi}^{\pi} = \\ &= \frac{1}{n^2 \pi} (\cos n\pi - \cos n(-\pi)) = 0; \end{aligned}$$

$$\begin{aligned} b_n &= \frac{1}{\pi} \int_{-\pi}^{\pi} x \sin nx dx = \frac{1}{\pi} \left(- \left. \frac{x \cos nx}{n} \right|_{-\pi}^{\pi} + \frac{1}{n} \int_{-\pi}^{\pi} \cos nx dx \right) = \\ &= \frac{1}{n\pi} \left(-\pi \cos n\pi - \pi \cos n(-\pi) + \frac{1}{n} \sin nx \Big|_{-\pi}^{\pi} \right) = -\frac{2}{n} \cos n\pi = -\frac{2}{n} (-1)^n = (-1)^{n+1} \frac{2}{n}. \end{aligned}$$

Shunday qilib, $f(x)$ funktsiyaning Fure qatori quyidagi ko'rinishda bo'ladi:

$$x = \sum_{n=1}^{\infty} (-1)^{n+1} \frac{2}{n} \sin nx = 2 \left(\frac{\sin x}{1} - \frac{\sin 2x}{2} + \frac{\sin 3x}{3} - \dots + (-1)^{n+1} \frac{\sin nx}{n} + \dots \right). \quad \text{☞}$$

4.3.2. Juft funktsiyaning Fure qatori faqat kosinuslarni o'z ichiga oladi:

$$f(x) = \frac{a_0}{2} + \sum_{n=1}^{\infty} a_n \cos nx,$$

bu yerda

$$a_0 = \frac{2}{\pi} \int_0^{\pi} f(x) dx, \quad a_n = \frac{2}{\pi} \int_0^{\pi} f(x) \cos nx dx.$$

Toq funksiyaning Fure qatori faqat sinuslarni o'z ichiga oladi:

$$f(x) = \sum_{n=1}^{\infty} b_n \sin nx,$$

bu yerda

$$b_n = \frac{2}{\pi} \int_0^{\pi} f(x) \sin nxdx.$$

2-misol. $[-\pi; \pi]$ intervalda $f(x) = |x|$ formula bilan berilgan 2π davrli $f(x)$ funksiyaning Fure qatoriga yoying (2-shakl) va yoyilmadan foydalanib

$\sum_{n=1}^{\infty} \frac{1}{(2n-1)^2}$ qatorning yig'indisini toping.

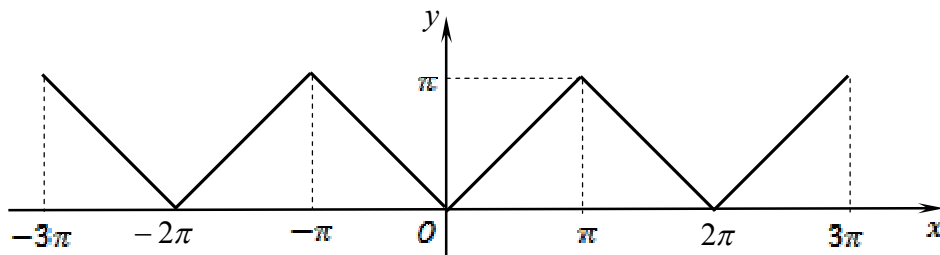

2-shakl

☞ Funksiya juft. Fure koeffitsiyentlarini topamiz:

$$a_0 = \frac{2}{\pi} \int_0^{\pi} x dx = \frac{2}{\pi} \frac{x^2}{2} \Big|_0^{\pi} = \pi;$$

$$a_n = \frac{2}{\pi} \int_0^{\pi} x \cos nxdx = \frac{2}{\pi} \left(\frac{x \sin nx}{n} \Big|_0^{\pi} - \frac{1}{n} \int_0^{\pi} \sin nxdx \right) = \frac{2}{n\pi^2} \cos nx \Big|_0^{\pi} = \frac{2}{n\pi^2} ((-1)^n - 1).$$

Shunday qilib,

$$|x| = \frac{\pi}{2} + \sum_{n=1}^{\infty} \frac{2}{n^2\pi} ((-1)^n - 1) \cos nx = \frac{\pi}{2} - \frac{4}{\pi} \left(\frac{\cos x}{1^2} + \frac{\cos 3x}{3^2} + \dots + \frac{\cos(2n-1)x}{(2n-1)^2} + \dots \right)$$

yoki

$$|x| = \frac{\pi}{2} - \frac{4}{\pi} \sum_{n=1}^{\infty} \frac{\cos(2n-1)x}{(2n-1)^2}.$$

$x = 0$ deb, topamiz:

$$0 = \frac{\pi}{2} - \frac{4}{\pi} \sum_{n=1}^{\infty} \frac{1}{(2n-1)^2}.$$

Bundan

$$\sum_{n=1}^{\infty} \frac{1}{(2n-1)^2} = \frac{\pi^2}{8}. \quad \text{☞}$$

4.3.3. Davri $2l$ bo'lgan $f(x)$ funksiyaning Fure qatori

$$f(x) = \frac{a_0}{2} + \sum_{n=1}^{\infty} \left(a_n \cos \frac{n\pi}{l} x + b_n \sin \frac{n\pi}{l} x \right),$$

bo'ladi, bu yerda

$$a_0 = \frac{1}{l} \int_{-l}^l f(x) dx, \quad a_n = \frac{1}{l} \int_{-l}^l f(x) \cos \frac{n\pi}{l} x dx, \quad b_n = \frac{1}{l} \int_{-l}^l f(x) \sin \frac{n\pi}{l} x dx .$$

Davri $2l$ bo'lgan juft va toq funksiyalarning Fure qatorlari quyidagicha topiladi:

Juft funksiya uchun

$$f(x) = \frac{a_0}{2} + \sum_{n=1}^{\infty} a_n \cos \frac{n\pi}{l} x,$$

bu yerda

$$a_0 = \frac{2}{l} \int_0^l f(x) dx, \quad a_n = \frac{2}{l} \int_0^l f(x) \cos \frac{n\pi}{l} x dx .$$

Toq funksiya uchun

$$f(x) = \sum_{n=1}^{\infty} b_n \sin \frac{n\pi}{l} x,$$

bu yerda

$$b_n = \frac{2}{l} \int_0^l f(x) \sin \frac{n\pi}{l} x dx .$$

3-misol. $(-1;1]$ intervalda $f(x) = x + 1$ formula bilan berilgan $2l = 2$ davrli funksiyani Fure qatoriga yoying.

☉ $l = 1$ uchun Fure koeffitsiyentlarini topamiz:

$$a_0 = \int_{-1}^1 (x+1) dx = \frac{(x+1)^2}{2} \Big|_{-1}^1 = 2;$$

$$a_n = \int_{-1}^1 (x+1) \cos n\pi x dx = \left| \begin{array}{l} u = x+1, \quad du = dx \\ dv = \cos n\pi x, \quad v = \frac{\sin n\pi x}{n\pi} \end{array} \right| =$$

$$= \frac{1}{n\pi} \left((x+1) \sin n\pi x \Big|_{-1}^1 - \int_{-1}^1 \sin n\pi x dx \right) =$$

$$= \frac{1}{n\pi} \frac{\cos n\pi x}{n\pi} \Big|_{-1}^1 = \frac{1}{n^2 \pi^2} [\cos n\pi - \cos(-n\pi)] = 0;$$

$$b_n = \int_{-1}^1 (x+1) \sin n\pi x dx = \frac{1}{n\pi} \left(-(x+1) \cos n\pi x \Big|_{-1}^1 - \int_{-1}^1 \cos n\pi x dx \right) =$$

$$= \frac{1}{n\pi} \left(-2 \cos n\pi + \frac{\sin n\pi}{n\pi} \Big|_{-1}^1 \right) = -\frac{2(-1)^n}{n\pi} = (-1)^{n+1} \frac{2}{n\pi} .$$

Demak,

$$x+1 = 1 + \frac{2}{\pi} \sum_{n=1}^{\infty} \frac{(-1)^{n+1} \sin n\pi x}{n} = 1 + \frac{2}{\pi} \left(\frac{\sin \pi x}{1} - \frac{\sin 2x}{2} + \dots + (-1)^{n+1} \frac{\sin n\pi x}{n} \right). \quad \odot$$

4.3.4. $f(x)$ funksiya $[-l;0]$ kesmada juft tarzda, ya'ni $x \in [-l;0]$ da $f(x) = f(-x)$ bo'ladigan qilib davom ettirilsa, uning Fure qatori faqat kosinuslar va ozod haddan iborat bo'ladi.

$f(x)$ funksiya $[-l;0]$ kesmada toq tarzda, ya'ni $x \in [-l;0]$ da $f(x) = -f(-x)$ bo'ladigan qilib davom ettirilsa, uning Fure qatori faqat sinuslardan iborat bo'ladi.

4-misol. $(0; \pi]$ intervalda berilgan $f(x) = x$ funksiyaning sinuslar va kosinuslar bo'yicha qatorga yoying.

☞ 1) Funksiyani sinuslar bo'yicha qatorga yoyamiz.

$$\begin{aligned} b_n &= \frac{2}{\pi} \int_0^{\pi} x^2 \sin nx dx = \frac{2}{\pi} \left(-\frac{x^2 \cos nx}{n} \Big|_0^{\pi} + \frac{2}{n} \int_0^{\pi} x \cos nx dx \right) = \\ &= \frac{2}{\pi} \left(-\frac{\pi^2 \cos n\pi}{n} + \frac{2}{n} \frac{x \sin nx}{n} \Big|_0^{\pi} - \frac{2}{n^2} \int_0^{\pi} \sin nx dx \right) = \\ &= \frac{2}{\pi} \left(-\frac{\pi^2 \cos n\pi}{n} + \frac{2}{n^3} \cos n\pi \Big|_0^{\pi} \right) = \frac{1}{\pi} \left(\frac{2}{n^3} ((-1)^n - 1) - \frac{\pi^2}{n} (-1)^n \right). \end{aligned}$$

Demak,

$$\begin{aligned} x^2 &= \sum_{n=1}^{\infty} \frac{2}{\pi} \left(\frac{2}{n^3} ((-1)^n - 1) - \frac{\pi^2}{n} (-1)^n \right) \sin nx = \\ &= 2\pi \left(\frac{\sin x}{1} - \frac{\sin 2x}{2} + \frac{\sin 3x}{3} - \dots \right) - \frac{8}{\pi} \left(\frac{\sin x}{1^3} + \frac{\sin 3x}{3^3} + \frac{\sin 5x}{5^3} + \dots \right). \end{aligned}$$

2) Funksiyani kosinuslar bo'yicha qatorga yoyamiz.

$$\begin{aligned} a_0 &= \frac{2}{\pi} \int_0^{\pi} x^2 dx = \frac{2}{\pi} \frac{x^3}{3} \Big|_0^{\pi} = \frac{2\pi^2}{3}; \\ a_n &= \frac{2}{\pi} \int_0^{\pi} x^2 \cos nx dx = \frac{2}{\pi} \left(\frac{x^2 \sin nx}{n} \Big|_0^{\pi} - \frac{2}{n} \int_0^{\pi} x \sin nx dx \right) = \\ &= \frac{4}{n\pi} \left(\frac{x \cos nx}{n} \Big|_0^{\pi} - \frac{1}{n} \int_0^{\pi} \cos nx dx \right) = \frac{4 \cos n\pi}{n^2} - \frac{4 \sin nx}{n^3 \pi} \Big|_0^{\pi} = \frac{4(-1)^n}{n^2}. \end{aligned}$$

Demak,

$$x^2 = \frac{\pi^2}{3} - 4 \left(\frac{\cos x}{1^2} - \frac{\cos 2x}{2^2} + \frac{\cos 3x}{3^2} - \dots \right). \quad \odot$$

Mashqlar

4.3.1. T davrli $f(x)$ funksiyani berilgan kesmada Fure qatoriga yoying:

1) $f(x) = x^2$, $T = 2\pi$, $(-\pi; \pi]$;

2) $f(x) = x^3$, $T = 2\pi$, $(-\pi; \pi]$;

3) $f(x) = x + |x|$, $T = 2\pi$, $(-\pi; \pi]$;

4) $f(x) = \pi - x$, $T = 2\pi$, $(-\pi; \pi]$;

5) $f(x) = \begin{cases} -4, & -\pi < x < 0, \\ 4, & 0 \leq x < \pi, \end{cases} T = 2\pi$;

6) $f(x) = \begin{cases} 0, & -\pi < x < 0, \\ x, & 0 \leq x < \pi, \end{cases} T = 2\pi$;

7) $f(x) = 1 - |x|$, $T = 6$, $[-3; 3]$;

8) $f(x) = 2x$, $T = 1$, $(0; 1)$;

9) $f(x) = \begin{cases} 3, & 0 < x \leq 2, \\ 0, & 2 < x < 4, \end{cases} T = 4$;

10) $f(x) = \begin{cases} 0, & -3 < x \leq 0, \\ x, & 0 < x < 3, \end{cases} T = 6$;

11) $f(x) = \pi - 2x$, $T = 2\pi$, $[-\pi; \pi]$, $f(x)$ funksiyani $[0; \pi]$ kesmada juft davom ettirib;

12) $f(x) = \begin{cases} x, & 0 \leq x \leq 1, \\ 2, & 1 < x \leq 2, \end{cases} [0; 4]$; $f(x)$ funksiyani $[0; 2]$ kesmada juft davom ettirib;

13) $f(x) = x$, $T = 2$, $[-1; 1]$, $f(x)$ funksiyani $[0; 1]$ kesmada toq davom ettirib;

14) $f(x) = x^2$, $T = 2\pi$, $[-\pi; \pi]$, $f(x)$ funksiyani $[0; \pi]$ kesmada toq davom ettirib.

4.3.2. Qatorning yig'indisini $f(x)$ funksiyaning berilgan kesmadagi Fure qatoriga yoyilmasidan foydalanib, toping:

1) $f(x) = x^2$, $(-\pi; \pi]$, $\sum_{n=1}^{\infty} (-1)^{n+1} \frac{1}{n^2}$;

2) $f(x) = \begin{cases} -1, & -\pi < x < 0, \\ 1, & 0 \leq x \leq \pi, \end{cases} \sum_{n=1}^{\infty} \frac{(-1)^{n-1}}{2n-1}$.

NAZORAT ISHI

1. Ishora almashinuvchi qatorni yaqinlashishga tekshiring.
2. Integralni 0,001 aniqlikda hisoblang.

1-variant

1. $\sum_{n=1}^{\infty} \frac{(-1)^{n-1} n}{\sqrt{2n^2 + 1}}$.

2. $\int_0^{0,2} \frac{1 - e^{-x}}{x} dx$.

2-variant

1. $\sum_{n=1}^{\infty} (-1)^{n-1} \ln\left(\frac{n+1}{n}\right)$.

2. $\int_0^{0,5} \frac{dx}{\sqrt[3]{1+x^3}}$.

3-variant

1. $\sum_{n=1}^{\infty} (-1)^n \cos \frac{\pi}{6n}$.

2. $\int_0^{0,5} \cos(4x^2) dx$.

4-variant

1. $\sum_{n=1}^{\infty} (-1)^{n+1} \operatorname{tg} \frac{1}{n}$.

2. $\int_0^1 \sin x^2 dx$.

5-variant

1. $\sum_{n=1}^{\infty} \frac{(-1)^{n-1}}{n^3 \sqrt{n}}$.

2. $\int_0^1 \frac{dx}{\sqrt[4]{16+x^4}}$.

6-variant

1. $\sum_{n=1}^{\infty} \frac{(-1)^{n-1}}{n \cdot 2^n}$.

2. $\int_0^{0,5} \sin(4x^2) dx$.

7-variant

1. $\sum_{n=1}^{\infty} \frac{(-1)^{n-1}}{6n}$.

2. $\int_0^2 \frac{dx}{\sqrt[4]{256+x^4}}$.

8-variant

1. $\sum_{n=1}^{\infty} \frac{(-1)^{n+1}}{n^2 + 1}$.

2. $\int_0^{0,1} \frac{1 - e^{-2x}}{x} dx$.

9-variant

1. $\sum_{n=1}^{\infty} \frac{(-1)^{n+1}}{\sqrt{n+1}}$.

2. $\int_0^{0,2} \cos(25x^2) dx$.

10-variant

1. $\sum_{n=1}^{\infty} \frac{(-1)^{n-1}}{n(2n+1)}$.

2. $\int_0^{0,4} e^{-\frac{3x^2}{4}} dx$.

11-variant

1. $\sum_{n=1}^{\infty} \frac{(-1)^{n+1} n^2}{n+8}$.

2. $\int_0^{2,5} \frac{dx}{\sqrt[3]{125+x^3}}$.

12-variant

1. $\sum_{n=1}^{\infty} \frac{(-1)^{n-1}}{\sqrt{n^2+1}}$.

2. $\int_0^{0,1} \sin(100x^2) dx$.

13-variant

1. $\sum_{n=1}^{\infty} \frac{(-1)^{n-1}}{2n+1}$.

2. $\int_0^1 \frac{\ln\left(1 + \frac{x}{5}\right)}{x} dx$.

14-variant

1. $\sum_{n=1}^{\infty} (-1)^n \frac{n+5}{3^n}$.

2. $\int_0^{0.5} \frac{dx}{\sqrt[4]{1+x^4}}$.

15-variant

1. $\sum_{n=1}^{\infty} \frac{(-1)^{n-1}}{n^2}$.

2. $\int_0^{0.3} e^{-2x^2} dx$.

16-variant

1. $\sum_{n=1}^{\infty} \frac{(-1)^{n+1} n^3}{n^2+1}$.

2. $\int_0^{0.4} \cos\left(\frac{5x}{2}\right)^2 dx$.

17-variant

1. $\sum_{n=1}^{\infty} \frac{(-1)^n (n+1)}{n!}$.

2. $\int_0^{0.4} \frac{1 - e^{-\frac{x}{2}}}{x} dx$.

18-variant

1. $\sum_{n=1}^{\infty} \frac{(-1)^{n-1} 3^4}{(2n+1)^n}$.

2. $\int_0^{0.1} e^{-6x^2} dx$.

19-variant

1. $\sum_{n=1}^{\infty} (-1)^n \left(\frac{n+1}{n}\right)^n$.

2. $\int_0^{1.5} \frac{dx}{\sqrt[4]{81+x^4}}$.

20-variant

1. $\sum_{n=1}^{\infty} (-1)^{n-1} \frac{2n+1}{n}$.

2. $\int_0^{0.2} \sin(25x^2) dx$.

21-variant

1. $\sum_{n=1}^{\infty} (-1)^n \frac{2n-7}{3n}$.

2. $\int_0^{0.4} \frac{\ln\left(1 + \frac{x}{2}\right)}{x} dx$.

22-variant

1. $\sum_{n=1}^{\infty} \frac{(-1)^n n!}{3^n}$.

2. $\int_0^{1.5} \frac{dx}{\sqrt[3]{27+x^3}}$.

23-variant

1. $\sum_{n=1}^{\infty} \frac{(-1)^{n-1}}{\ln n}$.

2. $\int_0^{0.1} \frac{\ln(1+2x)}{x} dx$.

24-variant

1. $\sum_{n=1}^{\infty} \frac{(-1)^n n}{6n+7}$.

2. $\int_0^{0.1} \cos(100x^2) dx$.

25-variant

1. $\sum_{n=1}^{\infty} (-1)^{n+1} \sin \frac{\pi}{2^n}$.

2. $\int_0^{0.2} e^{-3x^2} dx$.

26-variant

1. $\sum_{n=1}^{\infty} \frac{(-1)^n 2^n}{n!}$.

2. $\int_0^3 \frac{dx}{\sqrt[3]{64+x^3}}$.

27-variant

1. $\sum_{n=1}^{\infty} \frac{(-1)^n (2n+1)}{\sqrt{n^3}}$.

2. $\int_0^1 \cos x^2 dx$.

28-variant

1. $\sum_{n=1}^{\infty} (-1)^n \left(\frac{n}{2n+1} \right)^n$.

2. $\int_0^{2.5} \frac{dx}{\sqrt[4]{625+x^4}}$.

29-variant

1. $\sum_{n=1}^{\infty} (-1)^n \ln \left(1 + \frac{1}{n} \right)$.

2. $\int_0^{0.5} e^{-\frac{3x^2}{25}} dx$.

30-variant

1. $\sum_{n=1}^{\infty} \frac{(-1)^n (n^2-3)}{3n^2+2}$.

2. $\int_0^1 \frac{dx}{\sqrt[3]{8+x^3}}$.

MUSTAQIL UY ISHI

1. Qatorning yig'indisini toping.
- 2 - 6. Qatorni yaqinlashishga tekshiring.
7. Qator yig'indisini α aniqlikda hisoblang.
8. Qatorning yaqinlashish sohasini toping.
9. Qatorning yig'indisini toping.
10. Funktsiyani x ning darajalari bo'yicha Teylor qatoriga yoying.

1-variant

1. $\sum_{n=1}^{\infty} \frac{1}{n^2 + 15n + 56}$.
2. $\sum_{n=1}^{\infty} \frac{1}{(2n-1)2^{2n-1}}$.
3. $\sum_{n=1}^{\infty} \frac{1}{n3^{2n}}$.
4. $\sum_{n=1}^{\infty} \frac{1}{\ln^n(n+1)}$.
5. $\sum_{n=1}^{\infty} \frac{1}{n \ln^2 3n}$.
6. $\sum_{n=1}^{\infty} (-1)^n \frac{n}{3^n}$.
7. $\sum_{n=1}^{\infty} \frac{(-1)^{n+1}}{n!}$, $\alpha = 0,01$.
8. $\sum_{n=1}^{\infty} \frac{x^n}{n \cdot 3^n}$.
9. $\sum_{n=2}^{\infty} (n+1)x^{n-2}$.
10. $\frac{3}{2-x-x^2}$.

2-variant

1. $\sum_{n=1}^{\infty} \frac{1}{n^2 + 19n + 90}$.
2. $\sum_{n=1}^{\infty} \sin \frac{\pi}{2^n}$.
3. $\sum_{n=1}^{\infty} \frac{1}{(2n+1)!}$.
4. $\sum_{n=1}^{\infty} \left(\frac{n}{2n+1} \right)^n$.
5. $\sum_{n=2}^{\infty} \frac{1}{(n+2) \ln^2 n}$.
6. $\sum_{n=1}^{\infty} (-1)^n \frac{(n+1)}{\sqrt{n^3}}$.
7. $\sum_{n=1}^{\infty} \frac{(-1)^n}{(3n)!}$, $\alpha = 0,001$.
8. $\sum_{n=1}^{\infty} \frac{3^n x^n}{\sqrt[3]{n}}$.
9. $\sum_{n=3}^{\infty} (n+4)x^{n-3}$.
10. $\ln(1-x-6x^2)$.

3-variant

1. $\sum_{n=1}^{\infty} \frac{3}{9n^2 - 3n - 2}$.

3. $\sum_{n=1}^{\infty} \frac{2^n (n+2)!}{n^5}$.

5. $\sum_{n=1}^{\infty} \frac{1}{(n-1) \ln n}$.

7. $\sum_{n=1}^{\infty} \frac{(-1)^{n+1}}{3n^2}$, $\alpha = 0,01$.

9. $\sum_{n=0}^{\infty} n(2n+1)x^{n+2}$.

2. $\sum_{n=1}^{\infty} \frac{n+1}{n^2+1}$.

4. $\sum_{n=1}^{\infty} \left(\arcsin \frac{1}{n} \right)^n$.

6. $\sum_{n=1}^{\infty} (-1)^{n-1} \frac{1}{n \cdot 4^n}$.

8. $\sum_{n=1}^{\infty} \frac{(x-3)^n}{n!}$.

10. $x^2 \sqrt{4-3x}$.

4-variant

1. $\sum_{n=1}^{\infty} \frac{6}{4n^2 - 9}$.

3. $\sum_{n=1}^{\infty} \frac{n^n}{(n+1)!}$.

5. $\sum_{n=1}^{\infty} \frac{1}{\sqrt[4]{(4n+3)^3}}$.

7. $\sum_{n=1}^{\infty} \frac{(-1)^n}{n^3}$, $\alpha = 0,01$.

9. $\sum_{n=0}^{\infty} (2n^2 - n - 2)x^{n+1}$.

2. $\sum_{n=1}^{\infty} \frac{1}{n^2 - 4n + 5}$.

4. $\sum_{n=1}^{\infty} \left(\frac{n+2}{2n} \right)^{3n}$.

6. $\sum_{n=1}^{\infty} (-1)^n \frac{1}{n \ln n}$.

8. $\sum_{n=1}^{\infty} (3+x)^n$.

10. $\frac{\operatorname{sh} 2x - 2x}{x}$.

5-variant

1. $\sum_{n=1}^{\infty} \frac{5^n - 2^n}{10^n}$.

3. $\sum_{n=1}^{\infty} \frac{n+4}{n!}$.

5. $\sum_{n=1}^{\infty} \left(\frac{3+n}{9+n^2} \right)^2$.

7. $\sum_{n=1}^{\infty} \frac{(-1)^n}{(2n)!}$, $\alpha = 0,01$.

9. $\sum_{n=3}^{\infty} (n+3)x^{n-2}$.

2. $\sum_{n=1}^{\infty} \frac{1}{\sqrt{n^2 + 2n}}$.

4. $\sum_{n=1}^{\infty} \left(\frac{n}{4n+1} \right)^{2n}$.

6. $\sum_{n=1}^{\infty} (-1)^n \left(\frac{2n}{2n+1} \right)^n$.

8. $\sum_{n=1}^{\infty} \frac{(x+6)^n}{n^2}$.

10. $(x-1) \sin 5x$.

6-variant

1. $\sum_{n=1}^{\infty} \frac{3^n + 4^n}{12^n}$.

3. $\sum_{n=1}^{\infty} \frac{2^n}{n!}$.

5. $\sum_{n=2}^{\infty} \frac{1}{(n+2)\ln^2 n}$.

7. $\sum_{n=1}^{\infty} \left(-\frac{2}{5}\right)^n, \alpha = 0,01$.

9. $\sum_{n=0}^{\infty} (n+5)x^{n-1}$.

2. $\sum_{n=1}^{\infty} \left(\frac{1+n}{1+n^3}\right)^2$.

4. $\sum_{n=1}^{\infty} \left(\arcsin \frac{1}{3^n}\right)^n$.

6. $\sum_{n=1}^{\infty} (-1)^{n+1} \frac{1}{(n+1)!}$.

8. $\sum_{n=1}^{\infty} \frac{(x-3)^n}{n!}$.

10. $\frac{sh3x-1}{x^2}$.

7-variant

1. $\sum_{n=1}^{\infty} \frac{1}{n^2 + 6n + 5}$.

3. $\sum_{n=1}^{\infty} \frac{3^n}{2^n(2n+1)}$.

5. $\sum_{n=1}^{\infty} \frac{1}{(n+1)\ln^2(n+1)}$.

7. $\sum_{n=1}^{\infty} \frac{(-1)^n}{3^n n!}, \alpha = 0,001$.

9. $\sum_{n=0}^{\infty} (2n^2 + 5n + 3)x^{n+1}$.

2. $\sum_{n=1}^{\infty} (n+1)tg \frac{\pi}{3^n}$.

4. $\sum_{n=1}^{\infty} \left(\sin \frac{\pi}{n^2}\right)^{2n}$.

6. $\sum_{n=1}^{\infty} (-1)^n \ln\left(1 + \frac{1}{n}\right)$.

8. $\sum_{n=1}^{\infty} \frac{(x-1)^n}{n \cdot 9^n}$.

10. $\frac{9}{20-x-x^2}$.

8-variant

1. $\sum_{n=1}^{\infty} \frac{1}{n^2 + n - 12}$.

3. $\sum_{n=1}^{\infty} \frac{(2n+1)!}{2^n(n!)}$.

5. $\sum_{n=1}^{\infty} \frac{1}{\sqrt[3]{(3n-2)^4}}$.

7. $\sum_{n=1}^{\infty} \frac{(-1)^n}{(2n+1)!n!}, \alpha = 0,0001$.

9. $\sum_{n=0}^{\infty} (2n^2 - n - 1)x^n$.

2. $\sum_{n=1}^{\infty} \frac{2n-1}{2n^2+1}$.

4. $\sum_{n=1}^{\infty} \left(\frac{3n-1}{3n}\right)^{n^2}$.

6. $\sum_{n=1}^{\infty} (-1)^{n+1} \frac{1}{(n+1)^{\frac{3}{2}}}$.

8. $\sum_{n=1}^{\infty} \frac{(x-2)^n}{(3n+1)2^n}$.

10. $\frac{\sin 2x}{x} - \cos 2x$.

9-variant

1. $\sum_{n=1}^{\infty} \frac{1}{9n^2 + 3n - 2}$.

3. $\sum_{n=1}^{\infty} \frac{2n+1}{\sqrt{n} \cdot 3^n}$.

5. $\sum_{n=2}^{\infty} \frac{1}{(2n-1) \ln 2n}$.

7. $\sum_{n=1}^{\infty} \frac{(-1)^n}{(2n)!n!}$, $\alpha = 0,00001$.

9. $\sum_{n=1}^{\infty} (n+3)x^{n-1}$.

2. $\sum_{n=1}^{\infty} \left(1 - \cos \frac{\pi}{n}\right)$.

4. $\sum_{n=1}^{\infty} \left(\frac{n+3}{3n-1}\right)^{n^2}$.

6. $\sum_{n=1}^{\infty} (-1)^n \frac{\sin \sqrt{n}}{n\sqrt{n}}$.

8. $\sum_{n=1}^{\infty} (x+5)^n \operatorname{tg} \frac{1}{3^n}$.

10. $(3 + e^{-x})^2$.

10-variant

1. $\sum_{n=1}^{\infty} \frac{7^n - 3^n}{21^n}$.

3. $\sum_{n=1}^{\infty} \frac{n+4}{n!}$.

5. $\sum_{n=1}^{\infty} \frac{1}{(3n+1) \ln^2 n}$.

7. $\sum_{n=1}^{\infty} \frac{(-1)^n}{(2n+1)!}$, $\alpha = 0,0001$.

9. $\sum_{n=2}^{\infty} (n+4)x^{n-2}$.

2. $\sum_{n=1}^{\infty} \frac{1}{n^2 - \cos^2 n}$.

4. $\sum_{n=1}^{\infty} \left(\frac{2n+1}{3n+1}\right)^{\frac{n}{2}}$.

6. $\sum_{n=1}^{\infty} (-1)^{n-1} \frac{1}{2^n(n+1)}$.

8. $\sum_{n=1}^{\infty} (2-x)^n \sin \frac{\pi}{2^n}$.

10. $\sqrt[4]{16-5x}$.

11-variant

1. $\sum_{n=1}^{\infty} \frac{1}{n^2 + 9n + 20}$.

3. $\sum_{n=1}^{\infty} \frac{n}{2^n}$.

5. $\sum_{n=1}^{\infty} \frac{1}{(2n+1) \ln^2 2n}$.

7. $\sum_{n=1}^{\infty} \frac{(-1)^n}{n^n n!}$, $\alpha = 0,0001$.

9. $\sum_{n=0}^{\infty} (n^2 + 5n + 3)x^n$.

2. $\sum_{n=1}^{\infty} \frac{n}{n^2 \sqrt[3]{n} + 5}$.

4. $\sum_{n=1}^{\infty} \left(\operatorname{tg} \frac{\pi}{2n+1}\right)^n$.

6. $\sum_{n=1}^{\infty} (-1)^n \frac{1}{\sqrt{5n-1}}$.

8. $\sum_{n=1}^{\infty} \frac{n!}{n^n} x^n$.

10. $\frac{7}{12+x-x^2}$.

12-variant

- $$\sum_{n=1}^{\infty} \frac{12}{36n^2 + 12n - 35}.$$
- $$\sum_{n=1}^{\infty} \frac{n!}{n^n}.$$
- $$\sum_{n=1}^{\infty} \frac{1}{n \ln 5n}.$$
- $$\sum_{n=1}^{\infty} \frac{(-1)^{n+1}}{(2n)^3}, \alpha = 0,001.$$
- $$\sum_{n=0}^{\infty} (n^2 - 2n - 1)x^{n+2}.$$
- $$\sum_{n=1}^{\infty} \frac{1}{\sqrt[3]{n+1}} \sin \frac{1}{\sqrt{n}}.$$
- $$\sum_{n=1}^{\infty} 3^n \left(\frac{n}{n+1} \right)^{n^2}.$$
- $$\sum_{n=1}^{\infty} (-1)^n \frac{1}{n \sqrt[3]{n}}.$$
- $$\sum_{n=1}^{\infty} \frac{(x-1)^{2n}}{(2n-1)}.$$
- $$(x-1)shx.$$

13-variant

- $$\sum_{n=1}^{\infty} \frac{9^n - 2^n}{18^n}.$$
- $$\sum_{n=1}^{\infty} \frac{(n!)^2}{(2n)!}.$$
- $$\sum_{n=1}^{\infty} \frac{4+n}{16+n^2}.$$
- $$\sum_{n=1}^{\infty} \frac{(-1)^n}{2+n^3}, \alpha = 0,01.$$
- $$\sum_{n=3}^{\infty} (n+1)x^{n-3}.$$
- $$\sum_{n=1}^{\infty} n \left(e^{\frac{1}{n}} - 1 \right)^2.$$
- $$\sum_{n=1}^{\infty} \left(\operatorname{arctg} \frac{1}{3n+1} \right)^n.$$
- $$\sum_{n=1}^{\infty} (-1)^n \frac{5n+1}{7n-2}.$$
- $$\sum_{n=1}^{\infty} \frac{3^n x^n}{n!}.$$
- $$\frac{x^2}{\sqrt{4-5x}}.$$

14-variant

- $$\sum_{n=2}^{\infty} \frac{1}{n^2 + n - 2}.$$
- $$\sum_{n=1}^{\infty} \frac{n^2 + 3}{(n+1)!}.$$
- $$\sum_{n=2}^{\infty} \frac{1}{(2n-1) \ln(2n-1)}.$$
- $$\sum_{n=1}^{\infty} \frac{(-1)^n n}{2^n}, \alpha = 0,01.$$
- $$\sum_{n=0}^{\infty} (n^2 + n + 1)x^{n+3}.$$
- $$\sum_{n=1}^{\infty} n \sin \frac{1}{\sqrt{n^3}};$$
- $$\sum_{n=1}^{\infty} \left(\frac{n+1}{n} \right)^{n^2} \cdot \frac{1}{3^n}.$$
- $$\sum_{n=1}^{\infty} (-1)^n \frac{n+4}{3^n}.$$
- $$\sum_{n=1}^{\infty} \frac{n!}{(n+1)^n} x^n.$$
- $$\frac{\operatorname{arctg} x}{x}.$$

15-variant

- $$\sum_{n=1}^{\infty} \frac{6}{9n^2 + 12n - 5}.$$
- $$\sum_{n=1}^{\infty} \ln \frac{n^2 + 4}{n^2 + 3}.$$
- $$\sum_{n=1}^{\infty} \frac{1 \cdot 4 \cdot 7 \cdot \dots \cdot (3n - 2)}{7 \cdot 9 \cdot 11 \cdot \dots \cdot (2n + 5)}.$$
- $$\sum_{n=1}^{\infty} \left(\frac{n+1}{n} \right)^n \frac{1}{5^n}.$$
- $$\sum_{n=1}^{\infty} \frac{1}{(n+5) \ln^2(n+4)}.$$
- $$\sum_{n=1}^{\infty} (-1)^n \frac{1}{\ln(n+2)}.$$
- $$\sum_{n=1}^{\infty} \frac{(-1)^n (2n+1)}{n^3 (n+1)}, \quad \alpha = 0,01.$$
- $$\sum_{n=1}^{\infty} \frac{3^n n!}{n^n} x^n.$$
- $$\sum_{n=3}^{\infty} (n+2)x^{n-3}.$$
- $$\frac{x}{\sqrt[3]{27-2x}}.$$

16-variant

- $$\sum_{n=1}^{\infty} \frac{8^n - 3^n}{24^n}.$$
- $$\sum_{n=1}^{\infty} \left(e^{\frac{\sqrt{n}}{n^2-1}} - 1 \right)^2.$$
- $$\sum_{n=1}^{\infty} \frac{3^n (n^2 - 1)}{n!}.$$
- $$\sum_{n=1}^{\infty} 2^n \left(\frac{n}{n+1} \right)^n.$$
- $$\sum_{n=1}^{\infty} \frac{1}{\sqrt[6]{(3n+2)^7}}.$$
- $$\sum_{n=1}^{\infty} (-1)^n \frac{1}{(2n-1)^3}.$$
- $$\sum_{n=1}^{\infty} \frac{(-1)^n}{(2n-1)^3 (2n+1)^2}, \quad \alpha = 0,001.$$
- $$\sum_{n=1}^{\infty} \frac{(x-1)^n}{2^n (n+4)}.$$
- $$\sum_{n=0}^{\infty} (n^2 + 2n + 2)x^{n+2}.$$
- $$\frac{6}{8 + 2x - x^2}.$$

17-variant

- $$\sum_{n=1}^{\infty} \frac{1}{n^2 + 4n + 3}.$$
- $$\sum_{n=1}^{\infty} \arcsin \frac{n+1}{n^3 - 2}.$$
- $$\sum_{n=1}^{\infty} \frac{3n+1}{\sqrt{n} 3^n}.$$
- $$\sum_{n=1}^{\infty} \left(\frac{n+1}{n} \right)^{n^2} \frac{1}{2^n}.$$
- $$\sum_{n=2}^{\infty} \frac{1}{(3n-1) \ln n}.$$
- $$\sum_{n=1}^{\infty} (-1)^{n+1} \frac{1}{n \ln^2 n}.$$
- $$\sum_{n=1}^{\infty} \frac{(-1)^{n+1}}{n(n^2 + 1)}, \quad \alpha = 0,001.$$
- $$\sum_{n=1}^{\infty} \frac{(x+2)^n}{\sqrt[3]{n^2 + 1} \sqrt{n+1}}.$$
- $$\sum_{n=2}^{\infty} (n+5)x^{n-2}.$$
- $$(x-1)chx.$$

18-variant

- $\sum_{n=1}^{\infty} \frac{1}{16n^2 - 8n - 15}$.
- $\sum_{n=1}^{\infty} \frac{1}{n^2 - \ln n}$.
- $\sum_{n=1}^{\infty} \frac{(3n+2)!}{10^n n^2}$.
- $\sum_{n=1}^{\infty} \left(\frac{2n^2+1}{n^2+1} \right)^{n^2}$.
- $\sum_{n=2}^{\infty} \frac{1}{(n+2)\ln^2 n}$.
- $\sum_{n=1}^{\infty} (-1)^n \frac{n-3}{n^2-1}$.
- $\sum_{n=1}^{\infty} \frac{(-1)^{n+1}}{(n^3+1)^2}, \alpha = 0,001$.
- $\sum_{n=1}^{\infty} \frac{(x-3)^n}{(2n-1)3^n}$.
- $\sum_{n=0}^{\infty} (2n^2 + 7n + 5)x^{n+1}$.
- $\ln(1-x-12x^2)$.

19-variant

- $\sum_{n=1}^{\infty} \frac{1}{4n^2 + 8n + 3}$.
- $\sum_{n=1}^{\infty} \frac{1}{\sqrt[3]{n}} \operatorname{arctg} \frac{\pi}{4\sqrt{n}}$.
- $\sum_{n=1}^{\infty} \frac{3 \cdot 5 \cdot 7 \cdot \dots \cdot (2n+1)}{2 \cdot 5 \cdot 8 \cdot \dots \cdot (3n-1)}$.
- $\sum_{n=1}^{\infty} \left(\frac{n^2+2}{2n^2+1} \right)^{n^2}$.
- $\sum_{n=2}^{\infty} \frac{1}{(n+3)\ln^2 2n}$.
- $\sum_{n=1}^{\infty} (-1)^n \left(\frac{4n}{5n+1} \right)^n$.
- $\sum_{n=1}^{\infty} \left(-\frac{2}{3} \right)^n, \alpha = 0,01$.
- $\sum_{n=1}^{\infty} \frac{(x+1)^n}{5^n}$.
- $\sum_{n=1}^{\infty} (n+4)x^{n-1}$.
- $2x \sin^2 \left(\frac{x}{2} \right) - x$.

20-variant

- $\sum_{n=1}^{\infty} \frac{7^n - 2^n}{14^n}$.
- $\sum_{n=1}^{\infty} \frac{\sin \frac{2\pi}{3n-1}}{\sqrt[3]{n}}$.
- $\sum_{n=1}^{\infty} \frac{n^n}{(n+2)!}$.
- $\sum_{n=1}^{\infty} \left(\frac{3n-2}{4n+3} \right)^{n^2}$.
- $\sum_{n=2}^{\infty} \frac{1}{n \ln^3 2n}$.
- $\sum_{n=1}^{\infty} (-1)^n \frac{3^n}{2n+2}$.
- $\sum_{n=1}^{\infty} \frac{(-1)^n n}{7^n}, \alpha = 0,0001$.
- $\sum_{n=1}^{\infty} \left(\frac{nx}{3} \right)^n$.
- $\sum_{n=0}^{\infty} (n^2 - 2n - 2)x^{n+1}$.
- $\ln(1-x-20x^2)$.

21-variant

1. $\sum_{n=1}^{\infty} \frac{1}{4n^2 + 4n - 3}$.

3. $\sum_{n=1}^{\infty} \left(\frac{9}{10}\right)^n n^6$.

5. $\sum_{n=1}^{\infty} \left(\frac{2+n}{4+n^2}\right)^2$.

7. $\sum_{n=1}^{\infty} \frac{(-1)^n}{(2n)!2n}$, $\alpha = 0,001$.

9. $\sum_{n=0}^{\infty} (n^2 + 7n + 4)x^n$.

2. $\sum_{n=1}^{\infty} \frac{1}{\sqrt[3]{n}} \sin \frac{1}{n}$.

4. $\sum_{n=1}^{\infty} 2^n \left(\frac{n}{n+1}\right)^{n^2}$.

6. $\sum_{n=1}^{\infty} (-1)^n \frac{1}{(3n+1)^n}$.

8. $\sum_{n=1}^{\infty} \frac{n^2(x-2)^n}{n+1}$.

10. $\frac{5}{6+x-x^2}$.

22-variant

1. $\sum_{n=1}^{\infty} \frac{1}{n^2 + 13n + 42}$.

3. $\sum_{n=1}^{\infty} \left(\frac{4}{5}\right)^n \cdot \left(\frac{1}{n}\right)^5$.

5. $\sum_{n=1}^{\infty} \frac{1}{\sqrt{(5n-4)^3}}$.

7. $\sum_{n=1}^{\infty} \frac{(-1)^n}{2^n n!}$, $\alpha = 0,001$.

9. $\sum_{n=0}^{\infty} (n+2)x^{n-1}$.

2. $\sum_{n=1}^{\infty} \frac{1}{n-1} \operatorname{arctg} \frac{\pi}{\sqrt[3]{n-1}}$.

4. $\sum_{n=1}^{\infty} 4^n \left(\frac{n-1}{n}\right)^{n^2}$.

6. $\sum_{n=1}^{\infty} (-1)^{n-1} \frac{1}{(2n-1)!}$.

8. $\sum_{n=1}^{\infty} \frac{2^n(x+1)^n}{n(n+2)}$.

10. $\ln(1+x-12x^2)$.

23-variant

1. $\sum_{n=1}^{\infty} \frac{1}{9n^2 + 21n - 8}$.

3. $\sum_{n=1}^{\infty} \frac{1 \cdot 5 \cdot 9 \cdot \dots \cdot (4n-3)}{1 \cdot 4 \cdot 7 \cdot \dots \cdot (3n-2)}$.

5. $\sum_{n=3}^{\infty} \frac{1}{n \ln(n-1)}$.

7. $\sum_{n=0}^{\infty} \frac{(-1)^n n}{4^n(2n+1)}$, $\alpha = 0,001$.

9. $\sum_{n=0}^{\infty} (n^2 + 6n + 5)x^{n+1}$.

2. $\sum_{n=1}^{\infty} \frac{1}{2^{n-1} + n - 1}$.

4. $\sum_{n=1}^{\infty} 2^{n-1} e^{-n}$.

6. $\sum_{n=1}^{\infty} (-1)^n \left(\frac{2n+1}{2n}\right)^n$.

8. $\sum_{n=1}^{\infty} \left(\frac{x+4}{n+5}\right)^n x^n$.

10. $(2 - e^x)^2$.

24-variant

- $\sum_{n=1}^{\infty} \frac{4^n - 3^n}{12^n}$.
- $\sum_{n=1}^{\infty} n^3 \operatorname{tg} \frac{5\pi}{n}$.
- $(2n+1) \sin \frac{\pi}{3^n}$.
- $\sum_{n=1}^{\infty} \left(\frac{3n^2 - 1}{4n^2 + 2n + 1} \right)^n$.
- $\sum_{n=1}^{\infty} \frac{1}{n \ln^2(2n+1)}$.
- $\sum_{n=1}^{\infty} (-1)^{n+1} \frac{n+1}{n}$.
- $\sum_{n=0}^{\infty} \frac{(-1)^n 2^n}{(n+1)^n}$, $\alpha = 0,001$.
- $\sum_{n=1}^{\infty} \frac{(2x-3)^{3n}}{8^n}$.
- $\sum_{n=0}^{\infty} (n^2 - n + 1)x^n$.
- $\ln(1+x-6x^2)$.

25-variant

- $\sum_{n=1}^{\infty} \frac{1}{4n^2 + 8n + 3}$.
- $\sum_{n=1}^{\infty} \frac{1}{\sqrt{n+3}} \left(e^{\frac{1}{\sqrt{n}}} - 1 \right)$.
- $\sum_{n=1}^{\infty} \frac{(n+1)^{\frac{n}{2}}}{n!}$.
- $\sum_{n=1}^{\infty} \frac{2^{n+1}}{n^n}$.
- $\sum_{n=2}^{\infty} \frac{1}{2 \ln(n^2 - 1)}$.
- $\sum_{n=1}^{\infty} (-1)^n \frac{n^3}{2^n}$.
- $\sum_{n=0}^{\infty} \frac{(-1)^n n}{(n^3 + 1)^2}$, $\alpha = 0,001$.
- $\sum_{n=1}^{\infty} \frac{5^n}{n \sqrt{n}} x^n$.
- $\sum_{n=1}^{\infty} (n+6)x^{n-1}$.
- $\frac{1}{\sqrt[4]{16-3x}}$.

26-variant

- $\sum_{n=1}^{\infty} \frac{1}{9n^2 - 12n - 5}$.
- $\sum_{n=1}^{\infty} \frac{1}{\sqrt{n+1}} \sin \frac{1}{\sqrt{n+1}}$.
- $\sum_{n=1}^{\infty} \frac{(n+1)^n}{n!}$.
- $\sum_{n=1}^{\infty} \left(\frac{2n^2 + n + 1}{3n^2 + n + 1} \right)^n$.
- $\sum_{n=5}^{\infty} \frac{1}{(n-2)\sqrt{\ln(n-3)}}$.
- $\sum_{n=1}^{\infty} (-1)^{n+1} \frac{2n+1}{n(n+1)}$.
- $\sum_{n=1}^{\infty} \frac{(-1)^n n^2}{3^n}$, $\alpha = 0,01$.
- $\sum_{n=1}^{\infty} \left(1 + \frac{1}{n} \right)^n x^n$.
- $\sum_{n=0}^{\infty} (2n^2 - 2n + 1)x^n$.
- $\frac{7}{12-x-x^2}$.

27-variant

1. $\sum_{n=1}^{\infty} \frac{1}{4n^2 + 16n + 15}$.

3. $\sum_{n=1}^{\infty} \frac{n!}{5^n (n+1)!}$.

5. $\sum_{n=1}^{\infty} \left(\frac{1+n}{1+n^2} \right)^2$.

7. $\sum_{n=1}^{\infty} \frac{(-1)^n (2n+1)}{(2n)!n!}$, $\alpha = 0,001$.

9. $\sum_{n=0}^{\infty} (n^2 + 2n - 1)x^{n+1}$.

2. $\sum_{n=1}^{\infty} \frac{n+1}{n^3 \sqrt{n}}$.

4. $\sum_{n=1}^{\infty} \left(\operatorname{tg} \frac{\pi}{5^n} \right)^{3n}$.

6. $\sum_{n=1}^{\infty} (-1)^{n-1} \frac{2^{n-1}}{(n-1)!}$.

8. $\sum_{n=1}^{\infty} \frac{x^{3n}}{n^3}$.

10. $\ln(1 + 2x - 8x^2)$.

28-variant

1. $\sum_{n=1}^{\infty} \frac{4^n + 5^n}{20^n}$.

3. $\sum_{n=1}^{\infty} \frac{n^{\frac{n}{2}}}{4^n}$.

5. $\sum_{n=1}^{\infty} \frac{1}{(n+1) \ln^3(n+1)}$.

7. $\sum_{n=0}^{\infty} \frac{(-1)^n}{(n+1)^n}$, $\alpha = 0,01$.

9. $\sum_{n=2}^{\infty} nx^{n-2}$.

2. $\sum_{n=1}^{\infty} \frac{1}{\sqrt{n}} \arcsin \frac{n}{\sqrt{n^2 + 1}}$.

4. $\sum_{n=1}^{\infty} \frac{n^n}{(2n^2 + 1)^{\frac{n}{2}}}$.

6. $\sum_{n=1}^{\infty} (-1)^n \frac{n}{3n^2 + 1}$.

8. $\sum_{n=1}^{\infty} \frac{(x-1)^n}{2^n (n+4)}$.

10. $\frac{x}{\sqrt[3]{8-x}}$.

29-variant

1. $\sum_{n=1}^{\infty} \frac{1}{n^2 + 7n + 12}$.

3. $\sum_{n=1}^{\infty} \frac{1 \cdot 7 \cdot 13 \cdot \dots \cdot (6n-5)}{2 \cdot 3 \cdot 4 \cdot \dots \cdot (n+1)}$.

5. $\sum_{n=1}^{\infty} \frac{1}{2n \sqrt{\ln(3n-1)}}$.

7. $\sum_{n=1}^{\infty} \frac{(-1)^n 2}{n^2 (n+3)}$, $\alpha = 0,01$.

9. $\sum_{n=2}^{\infty} (n+2)x^{n-2}$.

2. $\sum_{n=1}^{\infty} \frac{n^2 + 2}{n^3 + 2}$.

4. $\sum_{n=1}^{\infty} \left(\arcsin \frac{1}{3n} \right)^{2n}$.

6. $\sum_{n=1}^{\infty} (-1)^{n+1} \frac{1}{\sqrt[3]{(n+1)^4}}$.

8. $\sum_{n=1}^{\infty} \frac{\sqrt{n}(x-3)^n}{n!}$.

10. $\frac{5}{6-x-x^2}$.

30-variant

1. $\sum_{n=1}^{\infty} \frac{1}{4n^2 + 8n - 5}$.

2. $\sum_{n=1}^{\infty} \frac{1}{n} \sin \frac{2\pi}{\sqrt{4n+3}}$.

3. $\sum_{n=1}^{\infty} \frac{(n+3)!}{n^n}$.

4. $\sum_{n=1}^{\infty} \frac{1}{3^n} \left(\frac{5n+1}{5n} \right)^{n^2}$.

5. $\sum_{n=1}^{\infty} \frac{1}{\sqrt[4]{(3n+13)^5}}$.

6. $\sum_{n=1}^{\infty} (-1)^{n-1} \frac{n+5}{3^n}$.

7. $\sum_{n=1}^{\infty} \frac{(-1)^{n+1}}{3^n(n+1)}, \alpha = 0,001$.

8. $\sum_{n=1}^{\infty} \frac{3^n(x-1)^n}{\sqrt[3]{n}}$.

9. $\sum_{n=0}^{\infty} (2n^2 + n + 1)x^{n+1}$.

10. $\frac{\arcsin x - x}{x}$.

NAMUNAVIY VARIANT YECHIMI

1. Qatorning yig'indisini toping:

1.30. $\sum_{n=1}^{\infty} \frac{1}{4n^2 + 8n - 5}$.

☞ Qatorning umumiy hadini sodda kasrlar yig'indisiga keltiramiz:

$$a_n = \frac{1}{4n^2 + 8n - 5} = \frac{1}{(2n-1)(2n+5)} = \frac{1}{6} \left(\frac{1}{2n-1} - \frac{1}{2n+5} \right)$$

Bundan

$$a_1 = \frac{1}{6} \left(1 - \frac{1}{7} \right), \quad a_2 = \frac{1}{6} \left(\frac{1}{3} - \frac{1}{9} \right), \quad a_3 = \frac{1}{6} \left(\frac{1}{5} - \frac{1}{11} \right), \quad a_4 = \frac{1}{6} \left(\frac{1}{7} - \frac{1}{13} \right), \dots$$

U holda

$$\begin{aligned} S_n &= \frac{1}{6} \left(1 - \frac{1}{7} \right) + \frac{1}{6} \left(\frac{1}{3} - \frac{1}{9} \right) + \frac{1}{6} \left(\frac{1}{5} - \frac{1}{11} \right) + \frac{1}{6} \left(\frac{1}{7} - \frac{1}{13} \right) + \dots + \frac{1}{6} \left(\frac{1}{2n-1} - \frac{1}{2n+5} \right) = \\ &= \frac{1}{6} \left(1 - \frac{1}{7} + \frac{1}{3} - \frac{1}{9} + \frac{1}{5} - \frac{1}{11} + \frac{1}{7} - \frac{1}{13} + \dots + \frac{1}{2n-1} + \frac{1}{2n+5} \right) = \\ &= \frac{1}{6} \left(1 + \frac{1}{3} + \frac{1}{5} - \frac{1}{2n+1} - \frac{1}{2n+3} - \frac{1}{2n+5} \right). \end{aligned}$$

Bundan

$$\lim_{n \rightarrow \infty} S_n = \lim_{n \rightarrow \infty} \frac{1}{6} \left(1 + \frac{1}{3} + \frac{1}{5} - \frac{1}{2n+1} - \frac{1}{2n+3} - \frac{1}{2n+5} \right) = \frac{23}{90}$$

Demak, qator yaqinlashadi va uning yig'indisi $\frac{23}{90}$ ga teng. ☞

2. Qatorni yaqinlashishga tekshiring:

$$2.30. \sum_{n=1}^{\infty} \frac{1}{n} \sin \frac{2\pi}{\sqrt{4n+3}}.$$

☞ Qatorni yaqinlashishga taqqoslashning limit alomati bilan tekshiramiz. Etalon qator sifatida umumiy hadi $b_n = \frac{\pi}{n\sqrt{n}}$ bo'lgan yaqinlashuvchi qatorni olamiz.

Berilgan va etalon qatorlar hadlari nisbatlarining limitini topamiz:

$$\begin{aligned} \lim_{n \rightarrow \infty} \frac{a_n}{b_n} &= \lim_{n \rightarrow \infty} \frac{\frac{1}{n} \sin \frac{2\pi}{\sqrt{4n+3}}}{\frac{\pi}{n\sqrt{n}}} = \lim_{n \rightarrow \infty} \frac{\sqrt{n}}{\pi} \cdot \sin \frac{2\pi}{\sqrt{4n+3}} = \\ &= \lim_{n \rightarrow \infty} \frac{\sqrt{n}}{\pi} \cdot \frac{2\pi}{\sqrt{4n+3}} \cdot \frac{\sin \frac{2\pi}{\sqrt{4n+3}}}{\frac{2\pi}{\sqrt{4n+3}}} = \lim_{n \rightarrow \infty} \frac{2\sqrt{n}}{\sqrt{4n+3}} = 1. \end{aligned}$$

Demak, taqqoslashning limit alomatiga ko'ra berilgan qator yaqinlashadi. ☞

3. Qatorni yaqinlashishga tekshiring:

$$3.30. \sum_{n=1}^{\infty} \frac{(n+3)!}{n^n}.$$

☞ Berilgan qatorda $a_n = \frac{(n+3)!}{n^n}$, $a_{n+1} = \frac{(n+4)!}{(n+1)^{n+1}}$. U holda

$$\lim_{n \rightarrow \infty} \frac{a_{n+1}}{a_n} = \lim_{n \rightarrow \infty} \frac{(n+4)! \cdot n^n}{(n+1)^{n+1} \cdot (n+3)!} = \lim_{n \rightarrow \infty} \left(\frac{n+4}{n+1} \right) \cdot \left(\frac{n}{n+1} \right)^n = \lim_{n \rightarrow \infty} \frac{1}{\left(1 + \frac{1}{n}\right)^n} = \frac{1}{e} < 1.$$

Demak, Dalamber alomatiga ko'ra qator yaqinlashadi. ☞

4. Qatorni yaqinlashishga tekshiring:

$$4.30. \sum_{n=1}^{\infty} \frac{1}{3^n} \left(\frac{5n+1}{5n} \right)^{n^2}.$$

☞ Qatorni yaqinlashishga Koshining ildiz alomati bilan tekshiramiz:

$$\lim_{n \rightarrow \infty} \sqrt[n]{a_n} = \lim_{n \rightarrow \infty} \sqrt[n]{\frac{1}{3^n} \left(\frac{5n+1}{5n} \right)^{n^2}} = \lim_{n \rightarrow \infty} \frac{1}{3} \left(\frac{5n+1}{5n} \right) = \frac{1}{3} \lim_{n \rightarrow \infty} \left[\left(1 + \frac{1}{5n} \right)^{5n} \right]^{\frac{1}{5}} = \frac{\sqrt[5]{e}}{3} < 1.$$

Demak, qator yaqinlashadi. ☞

5. Qatorni yaqinlashishga tekshiring:

$$5.30. \sum_{n=1}^{\infty} \frac{1}{\sqrt[4]{(3n+13)^5}}.$$

☞ Qatorni yaqinlashishga Koshining integral alomati bilan tekshiramiz:

$$\begin{aligned} \int_1^{+\infty} \frac{dx}{\sqrt[4]{(3x+13)^5}} &= \lim_{n \rightarrow +\infty} \int_1^b \frac{dx}{\sqrt[4]{(3x+13)^5}} = -\frac{4}{3} \lim_{n \rightarrow +\infty} \frac{1}{\sqrt[4]{3x+13}} \Big|_1^b = \\ &= -\frac{4}{3} \left(\lim_{n \rightarrow \infty} \frac{1}{\sqrt[4]{4b+13}} - \frac{1}{\sqrt[4]{16}} \right) = \frac{2}{3}. \end{aligned}$$

Xosmas integral yaqinlashadi.

Demak, Koshining integral alomatiga ko'ra berilgan qator yaqinlashadi. ☞

6. Qatorni yaqinlashishga tekshiring:

$$6.30. \sum_{n=1}^{\infty} (-1)^{n-1} \frac{n+5}{3^n}.$$

☞ Qatorning yoyilmasini yozamiz:

$$\sum_{n=1}^{\infty} (-1)^{n-1} \frac{n+5}{3^n} = \frac{6}{3} - \frac{7}{9} + \frac{8}{27} - \frac{9}{81} + \dots + (-1)^{n-1} \frac{n+5}{3^n} + \dots$$

Demak, qator ishora almashinuvchi. Bu qator hadlarining absolut qiymatlaridan tashkil topgan $\sum_{n=1}^{\infty} \frac{n+5}{3^n}$ qatorni Dalamber alomati bilan yaqinlashishga tekshiramiz:

$$\lim_{n \rightarrow \infty} \frac{a_{n+1}}{a_n} = \lim_{n \rightarrow \infty} \frac{n+6}{3^{n+1}} \cdot \frac{3^n}{n+5} = \frac{1}{3} \lim_{n \rightarrow \infty} \frac{n+6}{n+5} = \frac{1}{3} < 1.$$

$\sum_{n=1}^{\infty} \frac{n+5}{3^n}$ qator yaqinlashadi.

Demak, berilgan qator absolut yaqinlashadi. ☞

7. Qator yig'indisini α aniqlikda hisoblang:

$$7.30. \sum_{n=1}^{\infty} \frac{(-1)^{n+1}}{3^n (n+1)}, \alpha = 0,001.$$

☞ Qatorning yig'indisi $S = S_n + R_n$ ga teng bo'ladi, bu yerda R_n – qatorning n – qoldig'i. Misolning shartiga ko'ra $|R_n| \leq 0,001$. Ishora almashinuvchi qatorlar uchun qatorning qoldig'i moduli bo'yicha birinchi tashlab yuboriladigan haddan kichik bo'lishi kerak, ya'ni $|R_n| < a_{n+1}$.

Berilgan qator uchun $|R_n| < \frac{1}{3^{n+1}(n+2)} \leq 0,001$ tengsizlik bajarilishi kerak.

Bu tengsizlik $n=4$ da bajariladi. Demak, qatorning yig'indisini topish uchun birinchi to'rtta hadni olish yetarli bo'ladi:

$$\sum_{n=1}^{\infty} \frac{(-1)^{n+1}}{3^n(n+1)} \approx \frac{1}{3 \cdot 2} - \frac{1}{9 \cdot 3} + \frac{1}{27 \cdot 4} - \frac{1}{81 \cdot 5} = 0,137. \quad \odot$$

8. Qatorning yaqinlashish sohasini toping:

8.30. $\sum_{n=1}^{\infty} \frac{3^n(x-1)^n}{\sqrt[3]{n}}$.

☉ Qatorning yaqinlashish radiusini topamiz. Berilgan qator uchun

$$a_n = \frac{3^n}{\sqrt[3]{n}}, \quad a_{n+1} = \frac{3^{n+1}}{\sqrt[3]{n+1}}.$$

Bundan

$$R = \lim_{n \rightarrow \infty} \left| \frac{a_n}{a_{n+1}} \right| = \lim_{n \rightarrow \infty} \frac{3^n \cdot \sqrt[3]{n+1}}{\sqrt[3]{n} \cdot 3^{n+1}} = \frac{1}{3}.$$

Demak, qator $\left(1 - \frac{1}{3}; 1 + \frac{1}{3}\right)$, ya'ni $\left(\frac{2}{3}; \frac{4}{3}\right)$ oraliqda yaqinlashadi.

Intervalning chegaraviy nuqtalarida tekshiramiz.

$x = \frac{2}{3}$ da qator $\sum_{n=1}^{\infty} \frac{(-1)^n}{\sqrt[3]{n}}$ ko'rinishni oladi. Leybnits alomatiga ko'ra

$$1) \quad 1 > \frac{1}{\sqrt[3]{2}} > \frac{1}{\sqrt[3]{3}} > \dots; \quad 2) \quad \lim_{n \rightarrow \infty} \frac{1}{\sqrt[3]{n}} = 0.$$

Demak, qator $x = \frac{2}{3}$ da yaqinlashadi.

$x = \frac{4}{3}$ da qator $\sum_{n=1}^{\infty} \frac{1}{\sqrt[3]{n}}$ ko'rinishini oladi. Bu qator uzoqlashuvchi.

Shunday qilib, qatorning yaqinlashish sohasi $\left[\frac{2}{3}; \frac{4}{3}\right)$ dan iborat. ☉

9. Qatorning yig'indisini toping:

9.30. $\sum_{n=0}^{\infty} (n^2 + 6n + 5)x^{n+1}$.

☉ Qatorni uchta qator yig'indisiga keltiramiz:

$$\sum_{n=0}^{\infty} (2n^2 + n + 1)x^{n+1} = 2x \sum_{n=0}^{\infty} n^2 x^n + x \sum_{n=0}^{\infty} n x^n + x \sum_{n=0}^{\infty} x^n.$$

Har bir qatorning yig'indisini alohida hisoblaymiz:

$$\sum_{n=0}^{\infty} x^n = \frac{1}{1-x}, \quad |x| < 1;$$

$$\begin{aligned} \sum_{n=0}^{\infty} nx^n &= x \sum_{n=0}^{\infty} nx^{n-1} = x \sum_{n=0}^{\infty} \frac{d}{dx}(x^n) = x \frac{d}{dx} \left(\sum_{n=0}^{\infty} x^n \right) = x \frac{d}{dx} \left(\frac{1}{1-x} \right) = \frac{x}{(1-x)^2}; \\ \sum_{n=0}^{\infty} n^2 x^n &= x \sum_{n=0}^{\infty} n^2 x^{n-1} = x \sum_{n=0}^{\infty} \frac{d}{dx}(nx^n) = x \frac{d}{dx} \left(x \frac{d}{dx} \left(\sum_{n=0}^{\infty} x^n \right) \right) = \\ &= x \frac{d}{dx} \left(x \frac{d}{dx} \left(\frac{1}{1-x} \right) \right) = x \frac{d}{dx} \left(\frac{x}{(1-x)^2} \right) = \frac{x(x+1)}{(1-x)^3}. \end{aligned}$$

Bundan

$$\sum_{n=0}^{\infty} (2n^2 + n + 1)x^{n+1} = 2x \cdot \frac{x(x+1)}{(1-x)^3} + x \cdot \frac{x}{(1-x)^2} + x \cdot \frac{1}{1-x}$$

yoki

$$\sum_{n=0}^{\infty} (2n^2 + n + 1)x^{n+1} = \frac{2x^3 + x^2 + x}{(1-x)^3}, \quad |x| < 1. \quad \odot$$

10. Funksiyani x ning darajalari bo'yicha Teylor qatoriga yoying:

10.30. $\frac{\arcsin x - x}{x}$.

Avval $f(x) = \arcsin x$ funksiyaning qatorga yoyilmasini topamiz. Buning uchun

$$f'(x) = \frac{1}{\sqrt{1-x^2}} = (1-x^2)^{-\frac{1}{2}}$$

funksiyani qatorga yoyamiz. Bunda

$$\begin{aligned} (1+x)^\alpha &= 1 + \sum_{n=1}^{\infty} \frac{\alpha(\alpha-1)\cdots(\alpha-n+1)}{n!} x^n = \\ &= 1 + \alpha x + \frac{\alpha(\alpha-1)}{2!} x^2 + \dots + \frac{\alpha(\alpha-1)\cdots(\alpha-n+1)}{n!} x^n + \dots, \quad -1 < x < 1; \end{aligned}$$

yoyilmadan foydalanamiz. U holda

$$f'(x) = (1-x^2)^{-\frac{1}{2}} = 1 + \frac{1}{2}x^2 + \frac{3}{4} \cdot \frac{1}{2!}x^4 + \frac{15}{8} \cdot \frac{1}{3!}x^6 + \dots$$

bo'ladi. Bundan

$$\begin{aligned} f(x) = \arcsin x &= \int (1-x^2)^{-\frac{1}{2}} dx = \\ &= x + \frac{1}{2 \cdot 3} x^3 + \frac{1 \cdot 3}{2 \cdot 4 \cdot 5} x^5 + \frac{1 \cdot 3 \cdot 5}{2 \cdot 4 \cdot 6 \cdot 7} x^7 + \dots + \frac{1 \cdot 3 \cdot 5 \cdot \dots \cdot (2n-1)}{2 \cdot 4 \cdot 6 \cdot \dots \cdot (2n) \cdot (2n+1)} x^{2n+1} + \dots \end{aligned}$$

kelib chiqadi. Demak, berilgan qatorning Teylor qatoriga yoyilmasi

$$\frac{\arcsin x - x}{x} = \sum_{n=1}^{\infty} \frac{1 \cdot 3 \cdot 5 \cdot \dots \cdot (2n-1)}{2 \cdot 4 \cdot 6 \cdot \dots \cdot (2n) \cdot (2n+1)} x^{2n+1}, \quad |x| < 1 \quad \odot$$

FOYDALANILGAN ADABIYOTLAR

1. A.Sa'dullayev, G.Xudoyberganov, X. Mansurov, A.Vorisov, R G'ulomov. Matematik analizdan misol va masalalar to'plami. -T., «O'zbekiston», 1992.
2. Yo.U. Soatov. Oliy matematika. II tom. - T., «O'qituvchi», 1992.
3. Yo.U. Soatov. Oliy matematika. III tom.- T., «O'zbekiston», 1992.
4. Sh.I.Tojiev. Oliy matematikadan masalalar yechish. -T., «O'zbekiston»б 2002.
5. B.A.Shoimqulov, T.T.To'ychiyev, D.H.Djumabayev. Matematik analizdan mustaqil ishlar. T., 2008.
6. Y.P.Oppog'ov, N. Turg'unov, I.A.Safarov. Oddiy differensial tenglamalardan misol va masalalar to'plami. -T., «Voris-nashriyot», 2009.
7. Н.С.Пискунов. Дифференциальное и интегральное исчисление. Ч.1 и -М: 2001.
8. А.П.Рябушко и др. Сборник задач индивидуальных заданий по высшей математике. Ч. 2- Минск, Высшая школа, 1991.
9. О.В Зими́на, А.И.Кириллов, Т.А. Сальникова, Высшая математика. М.: Физматлит, 2001.
10. П.С. Данко, А.Г. Попов, Т.Я.Кожевникова. Высшая математика в упражнениях и задачах. Ч.1. -М.: 2003.
11. К.Н.Лунгу, Е.В.Макаров. Высшая математика. Руководство к решению задач. Ч.2 - М.: «Физматлит», 2007.
12. Черненко В.Д. Высшая математика в примерах и задачах. 2 том. СПб. «Политехника», 2003.
13. Пушкар Е.А. Дифференциальные уравнения в примерах и задачах. М.: МГИУ, 2007.

JAVOBLAR

1.1. Bir necha o'zgaruvchining funksiyasi

1.1.1. $S = \frac{xy}{2}$. 1.1.2. $V = \frac{1}{6}xy(2R + \sqrt{4R^2 - x^2 - y^2})$.

1.1.3. $S = \frac{1}{4}\sqrt{(a-2x)(a-2y)(a-2z)(2x+2y+2z-a)}$. 1.1.4. $r = \frac{xy}{x+z}$. 1.1.5. 1) $f(A) = \frac{7}{4}$,

$f(B) = \frac{y^3 - x^3}{xy^2}$, $f(C) = \frac{x^6 - y^6}{x^4y^2}$. 1.1.6. 1) $f(A) = -\frac{9}{2}$, $f(B) = \frac{(x-y)^2}{xy}$, $f(C) = \frac{(x^2 - y^2)^2}{x^2y^2}$.

1.1.7. $f(x,y) = \frac{ax-by}{ax+by}$. 1.1.8. $f(x,y) = 3x - 4y$. 1.1.9. 1) $\begin{cases} x < 0, \\ 1+x \leq y \leq 1-x, \end{cases} \begin{cases} x > 0, \\ 1-x \leq y \leq 1+x. \end{cases}$;

2) $\frac{x^2}{9} - \frac{y^2}{16} \leq 1$; 3) $x^2 + y^2 \neq 9$; 4) $(x+1)^2 + (y-2)^2 > 9$; 5) $x^2 - y^2 > 25$; 6) $0 \leq x^2 + y^2 \leq \pi$;

7) $\begin{cases} y^2 \leq x, \\ x^2 + y^2 < 1, \\ x \neq 0, y \neq 0 \end{cases}$; 8) $\begin{cases} y \geq 0, \\ x > \sqrt{y} \end{cases}$; 9) $y = -2x$; 10) $9 < x^2 + y^2 \leq 16$; 11) 1-oktant; 12) $\frac{x^2}{16} + \frac{y^2}{25} \leq z$;

13) $0 \leq x^2 + y^2 \leq z^2$, $z \neq 0$; 14) $\begin{cases} x^2 + y^2 + z^2 < 1, \\ x \neq 0, y \neq 0, z \neq 0 \end{cases}$; 15) $\frac{x^2}{a^2} + \frac{y^2}{b^2} - \frac{z^2}{c^2} \leq 1$; 16) $0 \leq x + y + z \leq 2a$.

1.1.10. 1) 12; 2) mavjud emas; 3) mavjud emas; 4) 0; 5) 0; 6) mavjud emas; 7) $\frac{1}{8}$; 8) 1;

9) e ; 10) $\frac{1}{e}$; 11) $\frac{e^2}{3}$; 12) $\frac{1}{2}$; 13) -6; 14) $+\infty$. 1.1.11. 1) mavjud emas; 2) (0,0); 3) (0,0);

4) (4,-1). 1.1.12.) $x = \pm y$ to'g'ri chiziqlarda uzilishga ega; 2) $y^2 = 2x$ parabolada uzilishga ega; 3) $x + 2y + z - 6 = 0$ tekislikda uzilishga ega; 4) $x^2 + y^2 + z^2 = 1$ sharda uzilishga ega.

1.2. Bir necha o'zgaruvchining funksiyasini differensiallash

1.2.1. $\Delta_x z = 0,31$; $\Delta_y z = 0,04$; $\Delta z = 0,33$. 1.2.2. $\Delta_x z = -0,96$; $\Delta_y z = 0,82$; $\Delta z = -0,258$.

1.2.3. 1) $z'_x = 4x^3 - 8xy^3$, $z'_y = 4y^3 - 12x^3y^2$; 2) $z'_x = y - \frac{y}{x^2}$, $z'_y = x + \frac{1}{x}$; 3) $z'_x = \frac{y}{2\sqrt{x}} + \frac{1}{\sqrt[3]{y}}$,

$z'_y = \sqrt{x} - \frac{x}{3y^3\sqrt{y}}$; 4) $z'_x = -\left(\frac{y}{x-y}\right)^2$, $z'_y = \left(\frac{x}{x-y}\right)^2$; 5) $z'_x = -\frac{y}{x^2 + y^2}$, $z'_y = \frac{x}{x^2 + y^2}$;

6) $z'_x = -\frac{2xy}{x^4 + y^2}$, $z'_y = \frac{x^2}{x^4 + y^2}$; 7) $z'_x = \left(1 + \frac{y}{x}\right)e^{-\frac{y}{x}}$, $z'_y = -e^{-\frac{y}{x}}$; 8) $z'_x = (5 + xy)^{x-1}(\ln(5 + xy) + xy)$,

$z'_y = x^2(5 + xy)^{x-1}$; 9) $z'_x = \text{ctg}(x - 2y)$, $z'_y = -2\text{ctg}(x - 2y)$; 10) $z'_x = \frac{2x}{x^2 + e^{-y}}$, $z'_y = -\frac{e^{-y}}{x^2 + e^{-y}}$;

11) $z'_x = -\frac{y}{x^2}e^{\frac{y}{x}}\ln y$, $z'_y = e^{\frac{y}{x}}\left(\frac{\ln y}{x} + \frac{1}{y}\right)$; 12) $z'_x = y^{xy+1}\ln y$, $z'_y = xy^{xy}(1 + \ln y)$; 13) $u'_x = 4x^3 + 3z - y$,

$u'_y = z^2 - x$, $u'_z = 2yz + 3x$; 14) $u'_x = yze^{xyx}$, $u'_y = xze^{xyx} + 3y^2$, $u'_z = xye^{xyx} - 20z^3$;

15) $u'_x = -yz \sin x(\cos)^{yz-1}$, $u'_y = z(\cos x)^{yz} \ln \cos x$, $u'_z = y(\cos x)^{yz} \ln \cos x$; 16) $u'_x = -\frac{y}{x^2}z^x \ln z$,

$$u'_y = \frac{1}{x} z^{\frac{y}{x}} \ln z, u'_z = \frac{y}{x} z^{\frac{y}{x}-1}. \quad \mathbf{1.2.4.} \quad 1) d_x z = y^2 x^{y^2-1} dx, \quad d_y z = 2yx^{y^2} \ln x dy, \quad dz = yx^{y^2} \left(\frac{y}{x} dx + 2 \ln x dy \right).$$

$$2) d_x z = \left(\cos x + \frac{3x^2}{x^3 + y^3} \right) dx, \quad d_y z = \frac{3y^2}{x^3 + y^3} dy, \quad dz = \left(\cos x + \frac{3x^2}{x^3 + y^3} \right) dx + \frac{3y^2}{x^2 + y^3} dy.$$

$$\mathbf{1.2.5.} \quad 1) du = \frac{1}{x^2 + y^2} \left(-\frac{2xz}{x^2 + y^2} dx - \frac{2yz}{x^2 + y^2} dy + dz \right); \quad 2) du = y^{xz} \left(z \ln y dx + \frac{xz}{y} dy + x \ln y dz \right).$$

$$\mathbf{1.2.6.} \quad 1) 1,98; \quad 2) 0,04. \quad \mathbf{1.2.7.} \quad 1) 2,87; \quad 2) 1,054. \quad \mathbf{1.2.8.} \quad \frac{dz}{dt} = \frac{2e^{2t}}{1 + e^{4t}}.$$

$$\mathbf{1.2.9.} \quad \frac{dz}{dt} = \sin 2t + e^t (\sin t + \cos t + 2e^t). \quad \mathbf{1.2.10.} \quad \frac{du}{dt} = \frac{2}{t}. \quad \mathbf{1.2.11.} \quad \frac{du}{dt} = e^{3t} (3t^2 + 5t + 1).$$

$$\mathbf{1.2.12.} \quad \frac{dz}{dx} = \frac{1}{1 + x^2}. \quad \mathbf{1.2.13.} \quad \frac{dz}{dx} = \frac{2(1 + xtgx)}{x}. \quad \mathbf{1.2.14.} \quad \frac{\partial z}{\partial u} = 2u^3 \sin 2v, \quad \frac{\partial z}{\partial v} = u^4 \cos 2v.$$

$$\mathbf{1.2.15.} \quad \frac{\partial z}{\partial u} = \frac{5e^{u+v}}{(2e^u + e^v)^2}, \quad \frac{\partial z}{\partial v} = -\frac{5e^{u+v}}{(2e^u + e^v)^2}. \quad \mathbf{1.2.16.} \quad \frac{\partial z}{\partial x} = \frac{2}{x + y}, \quad \frac{\partial z}{\partial y} = \frac{2}{x + y}.$$

$$\mathbf{1.2.17.} \quad \frac{\partial z}{\partial x} = 0, \quad \frac{\partial z}{\partial y} = -1. \quad \mathbf{1.2.18.} \quad 1) \frac{dy}{dx} = \frac{y^2}{1 - xy}; \quad 2) \frac{dy}{dx} = \frac{y^2 + xy + x^2}{xy}; \quad 3) \frac{dy}{dx} = \frac{1}{2}; \quad 4) \frac{dy}{dx} = \frac{y(x+2)}{x(y-1)}.$$

$$\mathbf{1.2.19.} \quad 1) \frac{d^2 y}{dx^2} = \frac{2y}{x^2}; \quad 2) \frac{d^2 y}{dx^2} = \frac{4(x+y)}{(x+y+1)^3}. \quad \mathbf{1.2.20.} \quad 1) \frac{\partial z}{\partial x} = \frac{x-3yz}{3xy-z}, \quad \frac{\partial z}{\partial y} = \frac{y-3yz}{3xy-z};$$

$$2) \frac{\partial z}{\partial x} = \frac{10xy + 2z^3}{y^2 - 6xz^2}, \quad \frac{\partial z}{\partial y} = \frac{15x^2 y^2 - 2yz}{y^2 - 6xz^2}; \quad 3) \frac{\partial z}{\partial x} = \frac{z(y-z \sin(x+z))}{xy + z^2 \sin(x+z)}, \quad \frac{\partial z}{\partial y} = \frac{xz}{xy + z^2 \sin(x+z)};$$

$$4) \frac{\partial z}{\partial x} = \frac{1 - z(x+z)e^{xyz}}{x(x+z)e^{xyz} - 1}, \quad \frac{\partial z}{\partial y} = \frac{(x+z)(\ln(x+z) - xze^{xyz})}{y(x(x+z)e^{xyz} - 1)}. \quad \mathbf{1.2.21.} \quad 1) 4x - 4y - z - 2 = 0,$$

$$\frac{x-2}{4} = \frac{y-1}{-4} = \frac{z-2}{-1}; \quad 2) 4x - z = 0, \quad \frac{x-1}{4} = \frac{y-3}{0} = \frac{z-4}{-1}; \quad 3) x - y - 2z = 0, \quad \frac{x-1}{1} = \frac{y-1}{-1} = \frac{z}{-2};$$

$$4) 2x - z - 2 = 0, \quad \frac{x-1}{2} = \frac{y}{0} = \frac{z}{-1}; \quad 5) x - 3y + 2z + 14 = 0, \quad \frac{x+1}{1} = \frac{y-3}{-3} = \frac{z+2}{2};$$

$$6) x + 11y + 5z - 18 = 0, \quad \frac{x-1}{1} = \frac{y-2}{11} = \frac{z+1}{5}. \quad \mathbf{1.2.22.} \quad 1) z''_{xx} = -\frac{4y}{(x+y)^3}, \quad z''_{xy} = z''_{yx} = \frac{2(x-y)}{(x+y)^3},$$

$$z''_{yy} = \frac{4x}{(x+y)^3}; \quad 2) z''_{xx} = -\frac{2xy}{(x^2 + y^2)^2}, \quad z''_{xy} = z''_{yx} = \frac{x^2 - y^2}{(x^2 + y^2)^2}, \quad z''_{yy} = \frac{2xy}{(x^2 + y^2)^2}.$$

$$\mathbf{1.2.25.} \quad z'''_{y^2x} = \frac{4x(3y^2 - x^2)}{(x^2 + y^2)^3}. \quad \mathbf{1.2.26.} \quad z'''_{xyz} = (x^2 y^2 z^2 + 3xyz + 1)e^{xyz}.$$

$$\mathbf{1.2.27.} \quad d^2 z = -\frac{y}{x^2} dx^2 + \frac{2}{x} dx dy, \quad d^3 z = \frac{2y}{x^3} dx^3 - \frac{3}{x^2} dx^2 dy.$$

1.3. Bir necha o'zgaruvchi funksiyasini ekstremumga tekshirish

- 1.3.1.** 1) $z_{\min} = z(1, -1) = -3$; 2) $z_{\min} = z(1, 1) = -1$; 3) $z_{\min} = z(1, 1) = z(1, -1) = -2$;
 4) $z_{\min} = z(\sqrt{2}, -\sqrt{2}) = z(-\sqrt{2}, \sqrt{2}) = -8$; 5) $z_{\min} = z(1, -3) = 17$; 6) $z_{\min} = z(5, 2) = 30$;
 7) $z_{\max} = z(4, 4) = 12$; 8) ekstremum nuqtasi yo'q; 9) $z_{\max} = z\left(\frac{1}{4}, \frac{1}{2}\right) = \frac{1}{64}$;

$$10) z_{\max} = z\left(\frac{2}{3}, \frac{2}{3}\right) = -\frac{8}{27}; 11) z_{\max} = z(-4, -2) = 8e^{-2}; 12) z_{\min} = z(-2, 0) = -\frac{2}{e}.$$

$$1.3.2.1) z_{\text{eng.kat.}} = z(0, 0) = 0, z_{\text{eng.kich.}} = z(-2, 0) = z(0, -2) = -4; 2) z_{\text{eng.kat.}} = z(0, 6) = z(4, 0) = 12, z_{\text{eng.kich.}} = z(2, 3) = -7; 3) z_{\text{eng.kat.}} = z(2, -1) = 13, z_{\text{eng.kich.}} = z(1, 1) = z(0, -1) = -1;$$

$$4) z_{\text{eng.kat.}} = z(4, 2) = 64, z_{\text{eng.kich.}} = z(0, 0) = z(0, 6) = z(6, 0) = z(0, 2) = 0; 5) z_{\text{eng.kat.}} = z\left(2, \frac{1}{2}\right) = \frac{7}{2}, z_{\text{eng.kich.}} = z\left(2, -\frac{3}{2}\right) = -\frac{9}{2}; 6) z_{\text{eng.kat.}} = z\left(\frac{2}{\sqrt{5}}, \frac{4}{\sqrt{5}}\right) = 2\sqrt{5} - 3, z_{\text{eng.kich.}} = z\left(-\frac{2}{\sqrt{5}}, -\frac{4}{\sqrt{5}}\right) = -2\sqrt{5} - 3.$$

$$1.3.3. 1) z_{\max} = z(1, 3) = 10, z_{\min} = z(-1, -3) = -10; 2) z_{\min} = z(2, 2) = 4, z_{\max} = z(-2, -2) = -4;$$

$$3) z_{\max} = z(-1, -1) = z(1, 1) = 1, z_{\min} = z(-1, 1) = z(1, -1) = -1; 4) z_{\max} = z\left(\frac{1}{2}, \frac{1}{2}\right) = \frac{1}{4};$$

$$5) z_{\max} = z\left(\frac{1}{3}, \frac{1}{3}\right) = \frac{1}{27}, z_{\min} = z(1, 0) = 0; 6) z_{\max} = z(0, -1) = 0, z_{\min} = z(0, 1) = 0,$$

$$z_{\max} = z\left(-\sqrt{\frac{2}{3}}, \sqrt{\frac{1}{3}}\right) = \frac{2\sqrt{3}}{9}, z_{\min} = z\left(\sqrt{\frac{2}{3}}, \sqrt{\frac{1}{3}}\right) = \frac{2\sqrt{3}}{9}, z_{\max} = z\left(-\sqrt{\frac{2}{3}}, -\sqrt{\frac{1}{3}}\right) = -\frac{2\sqrt{3}}{9},$$

$$z_{\max} = z\left(\sqrt{\frac{2}{3}}, -\sqrt{\frac{1}{3}}\right) = -\frac{2\sqrt{3}}{9}; 7) z_{\min} = z\left(\frac{1}{2}, \frac{1}{2}\right) = \frac{1}{2}; 8) z_{\max} = z(-1, 0) = z(1, 0) = 3,$$

$$z_{\min} = z(0, 1) = z(0, -1) = -2; 9) z_{\min} = z(1, 1) = 2; 10) z_{\max} = z(4, 2) = \frac{1}{32}; 11) z_{\max} = z\left(\frac{1}{2}, \frac{1}{2}\right) = \frac{\sqrt{2}}{2};$$

$$12) z_{\max} = z(1, 1) = e. 1.3.4. a = b = \sqrt[3]{2V}, h = \frac{\sqrt[3]{2V}}{2}. 1.3.5. x = y = z = \frac{2R\sqrt{3}}{3}.$$

$$1.3.6. 1) y = 0,74x + 1,55; 2) y = 2,11x + 0,43.$$

2.1. Ikki karrali integrallar

$$2.1.1. 1) (8\pi; 56\pi); 2) (0; 1); 3) \left(-8; \frac{2}{3}\right); 4) (4; 64). 2.1.2. 1) \int_0^1 dx \int_x^{3\sqrt{x}} f(x, y) dy; 2) \int_0^4 dy \int_{\frac{3\sqrt{y}}{2}}^{\sqrt{25-y^2}} f(x, y) dx;$$

$$3) \int_{-1}^0 dx \int_{-2\sqrt{x+1}}^{2\sqrt{x+1}} f(x, y) dy + \int_0^8 dx \int_{-2\sqrt{x+1}}^{2-x} f(x, y) dy; 4) \int_0^3 dy \int_{\sqrt{9-y^2}}^3 f(x, y) dx + \int_3^4 dy \int_0^3 f(x, y) dx + \int_4^5 dy \int_0^{\sqrt{25-y^2}} f(x, y) dx.$$

$$2.1.3. 1) 2; 2) \frac{1}{40}; 3) \frac{e^2 + 1}{4}; 4) \frac{1}{6} \ln^3 2. 2.1.4. 1) \frac{26}{105}; 2) \frac{51}{20}; 3) (e-1)(e^\pi - 1); 4) \pi - 2;$$

$$5) \frac{\pi - 2\sqrt{2} + 1}{4}; 6) \frac{9}{4}; 7) \frac{\pi}{6}; 8) \frac{1}{6}(e^6 - 3e^2 + 2); 9) \frac{8a^3}{105}; 10) \frac{a^3 b^2}{15}; 11) \frac{20}{3}; 12) 2 \ln 2; 13) 18\pi;$$

$$14) \frac{49\pi}{3}; 15) \frac{\pi}{2} \ln 3; 16) 18\pi; 17) \frac{8\pi}{3}; 18) 3\pi; 19) 18; 20) \frac{7}{2}. 2.1.5. 1) \frac{9}{2}; 2) \frac{ab}{6}; 3) 2\pi - \frac{4}{3};$$

$$4) \frac{5}{2} - 6 \ln \frac{3}{2}; 5) 3(\pi + 2); 6) 4; 7) 3 \ln 3; 8) 24\pi. 2.1.6. 1) \frac{13\pi}{3}; 2) \frac{2\pi}{3}(5\sqrt{5} - 1); 3) 4\sqrt{2}\pi; 4)$$

$$6\sqrt{3}. 2.1.7. 1) \frac{a^3}{6}; 2) 8\pi \ln 2; 3) 8; 4) \frac{88}{105}; 5) \frac{3}{35}; 6) 8\pi; 7) \frac{256}{21}; 8) \frac{128}{15}; 9) \frac{3}{4} \ln 3; 10) 72.$$

2.1.8.1) $\frac{27}{4}$; 2) 104. 2.1.9. $x_c = \frac{a}{3}$, $y_c = \frac{b}{3}$. 2.1.10. $x_c = \frac{3}{2}$, $y_c = \frac{6}{5}$. 2.1.11. $I_y = \frac{128}{15}$. 2.1.12. $I_y = 4$.

2.2. Uch karrali integrallar

2.2.1. 1) -26 ; 2) $e-1$; 3) $\frac{81}{4}$; 4) $\frac{1}{6}$. 2.2.2. 1) 4; 2) $\frac{1}{720}$; 3) $\frac{1}{6}$; 4) 8; 5) $\frac{16\pi}{3}$; 6) 8; 7) $\frac{64}{3}$; 8) $\frac{32\sqrt{2}}{135}$; 9) $\frac{128\pi}{5}$; 10) $\frac{1}{105}$. 2.2.3. 1) $\frac{7}{12}$; 2) 18; 3) 16π ; 4) $\frac{\pi^2}{128}$. 2.2.4. $m = \frac{k\pi}{4}$. 2.2.5. $c\left(0; 0; \frac{2}{3}\right)$. 2.2.6. $c\left(0; 0; \frac{3R}{8}\right)$. 2.2.7. $I_0 = \frac{3PR^2}{5g}$, $I_R = \frac{2PR^2}{5g}$. 2.2.8. $I_z = \frac{32\sqrt{2}a^5}{135}$.

2.3. Egri chiziqli integrallar

2.3.1. 1) $\frac{35}{2}$; 2) $\frac{\pi}{2}$; 3) $5\sqrt{5}-1$; 4) 16; 5) 10; 6) $\frac{2R^4}{3}$; 7) $\frac{256}{15}a^3$; 8) $2\pi a\sqrt{2a}$; 9) $4\pi(1+4\pi^2)$; 10) $\frac{\sqrt{2}}{2}$. 2.3.2. 1) $-\frac{5}{2}$; 2) $-\frac{8}{5}$; 3) $\frac{2e-1}{2}$; 4) e^2+1 ; 5) $\frac{2}{3}ab(b-a)$; 6) a) $2\pi R^2$; b) $\frac{2}{3}$; c) 12π ; d) 24π ; 7) 7; 8) $\frac{64\pi^3}{3}$. 2.3.3. 1) -1 ; 2) πR^4 . 2.3.4. 1) $u = \frac{1}{2}x^2 + x \sin y - \cos y + C$; 2) $u = xy + e^x \sin y + C$. 2.3.5. $\frac{15}{2}$. 2.3.6. $\frac{13}{3}$. 2.3.7. 24π . 2.3.8. $4a\gamma$. 2.3.9. $\frac{\pi}{8}$. 2.3.10. $\frac{11}{6}$. 2.3.11. πab . 2.3.12. $6\pi a^2$. 2.3.13. $2\pi(a^2 + \pi b^2)$. 2.3.14. $\frac{R^3}{3}$.

2.4. Sirt integrallari

2.4.1. 1) $54\sqrt{14}$; 2) $\frac{\sqrt{3}}{360}$; 3) $\frac{2\sqrt{2}\pi}{3}$; 4) 3π ; 5) 8π ; 6) $\frac{3\pi R^3}{4}$. 2.4.2. 1) 3; 2) $\frac{1}{2}$; 3) $\frac{81}{5}$; 4) $4\pi a$; 5) $\frac{4\pi}{3}$; 6) $\frac{4HR^3}{15}$. 2.4.3. 1) $4\pi abc$; 2) $6\pi R^2 h$; 3) $\frac{ba^2}{12}(16a+3b\pi)$; 4) $\frac{12}{5}\pi R^5$. 2.4.4. 1) $-\frac{R^4\pi}{4}$; 2) -4π . 2.4.5. 1) 14; 2) $\sqrt{141}$. 2.4.6. $\frac{28}{9}\pi$. 2.4.7. πR^2 . 2.4.8. $\frac{\pi^2 R^3}{2}$. 2.4.9. $\frac{\sqrt{2}\pi h^4}{2}$.

2.5. Maydonlar nazariyasi elementlari

2.5.1. 1) $\sqrt{2}$; 2) $\frac{3\sqrt{10}}{95}$; 3) $\frac{2\sqrt{3}}{3}$; 4) $\frac{68}{13}$; 5) $2+\sqrt{2}$; 6) $\frac{2-e}{3}$; 7) 0. 2.5.2. 1) 6; 2) $\frac{3}{4}$; 3) $\sqrt{33}$; 4) $4\sqrt{10}$. 2.5.3. 1) $\frac{\pi}{2}$; 2) $\frac{\pi}{2}$. 2.5.4. 1) $x = C_1 y$, $y = C_2 z$; 2) $x = C_1 e^y$, $y = C_2 z^{\frac{2}{3}}$; 3) $3x^2 + 2z^2 = C_1$, $y = C_2$. 2.5.5. 1) $x = 4\pi R^3$; 2) $\frac{\pi}{6}$. 2.5.6. 1) 108π ; 2) $\frac{4\pi}{5}R^5$; 3) $6\pi R^2 H$; 4) π ; 5) $\frac{1}{6}$; 7) 4π . 2.5.7. 1) $\frac{2}{3}$; 2) 2. 2.5.8. 1) $ab\pi$; 2) 2π ; 3) -8π ; 4) 18. 2.5.9. 1) 6; 2) 5.

3.1. Birinchi tartibli differensial tenglamalar

3.1.1. $mv' + kv^2 = 0$. 3.1.2. $mv' + kv = 0$. 3.1.3. $mv' = mg - kv^2$. 3.1.4. $mv' - k\frac{t}{v} = 0$.

3.1.5. $y' + \frac{y}{2x} = 0$. **3.1.6.** $x' - \frac{x}{y} = \pm \frac{2S}{y^2}$. **3.1.8.** 1) $x^2 + y^2 = C^2$; 2) $x^2 - y^3 - y = C$;
 3) $y = C(x+1)e^{-x}$; 4) $y = \arccos e^{Cx}$; 5) $y = \frac{1}{\sin x}$; 6) $\operatorname{tg} x \cdot \operatorname{tgy} = \pm 1$; 7) $e^x + e^{-y} = C$;
 8) $x^3 + y^3 - 3y = C$; 9) $\sin y \cos x = C$; 10) $\operatorname{tg} \left| \frac{y}{4} \right| = C - \sin \frac{x}{2}$; 11) $\sqrt{1-y^2} = \arcsin x + C$;
 12) $\frac{1+x^2}{1+y^2} = C$; 13) $y = e^{\operatorname{tg} \frac{x}{2}}$; 14) $y = 2 \sin^2 x - \frac{1}{2}$; 15) $y - x = \ln xy$; 16) $y = \sqrt{1+e^{2x}}$;
 17) $y = x + Ce^{-x}$; 18) $y = C + \ln |x+2y+2|$; 19) $\sqrt{4x-2y-1} + 2 \ln |2 - \sqrt{4x-2y-1}| = -x + C$;
 20) $\operatorname{tg} \left(\frac{y-x}{2} \right) = \frac{2}{x+C} + 1$. **3.1.9.** 1) $y = Cx^2 - x$; 2) $y^2 - 2xy - x^2 = C$; 3) $y = x \ln \left| \frac{Cx}{y^2} \right|$;
 4) $y + \sqrt{x^2 + y^2} = C$; 5) $\frac{x^2}{2y^2} + \ln |yC| = 0$; 6) $\operatorname{arctg} \frac{y}{x} = \ln |Cx|$; 7) $e^{-\frac{y}{x}} = \ln |Cx|$;
 8) $y = \arcsin(Cx)$; 9) $2\sqrt{\frac{x}{y}} + \ln |y| = 2$; 10) $y^3 = y^2 - x^2$; 11) $x^2 + y^2 + xy + x - y = C$;
 12) $(y+2)^2 = C(x+y-1)$, $y = -2$; 13) $x + 2y + 5 \ln |x+y-3| = C$; 14) $2y - x - \ln |2x+y-1| = C$.
3.1.10. 1) $z' = \frac{2xz}{x^2 - z^2}$; 2) $z' = \frac{4z-x}{4z}$. **3.1.11.** $y^2 = 2C \left(x + \frac{C}{2} \right)$. **3.1.12.** $y = (x+y)^2$.
3.1.13. 1) $y = (2x+1) \ln |2x+1| + C(2x+1) + 1$; 2) $y = 1 + \frac{\ln \left| C \operatorname{tg} \frac{x}{2} \right|}{\cos x}$; 3) $x = y^2 + Cy$;
 4) $x = Cy^2 - \frac{1}{y}$. **3.1.14.** 1) $y = x^4 + Cx^2$; 2) $y = x \ln |x| + \frac{C}{x}$; 3) $y = \frac{e^x - e^2 + 6}{x}$; 4) $y = \sin x$.
3.1.15. $y = e^x - x - 1$. **3.1.16.** $v = \frac{mg}{k} \left(1 - e^{-\frac{k}{m}t} \right)$. **3.1.17.** 1) $y = \frac{1}{(x+1)(C + \ln |x+1|)}$;
 2) $y = \frac{1}{x^3 \sqrt{3 \ln \left| \frac{C}{x} \right|}}$; 3) $y^2 = x \ln \left| \frac{C}{x} \right|$; 4) $y = \frac{1}{1 + \ln |x| + Cx}$; 5) $y = \frac{1}{(x+C) \cos x}$; 6) $y = \frac{1}{(1+x^3) \cos x}$.
3.1.18. 1) $x^2 + 2xy - 2y^2 + C$; 2) $4y \ln x + y^4 = C$; 3) $x^3 + 2xy - 3y = C$; 4) $xe^{-y} - y^2 = C$; 5)
 $x^2 + x \ln |y| - \cos y = C$; 6) $x^4 - x^2 y^2 + y^4 = C$. **3.1.19.** 1) $x - \frac{y}{x} = C$; 2) $x^2 y + 2x = Cy$;
 3) $x - e^{-y} \cos x = C$; 4) $x^2 + \sin^2 y = Cx$. **3.1.20.** 1) $x = (1+p)e^p + C$, $y = p^2 e^p$;
 2) $x = \frac{1}{\sqrt{p-1}} + C$, $y = \frac{2-p}{\sqrt{p-1}}$; 3) $y = p\sqrt{1+p^2}$, $x = 2\sqrt{1+p^2} - \ln |\sqrt{1+p^2} - 1| + \ln |p| + C$, $y = 0$;
 4) $x = e^p + C$, $y = (p-1)e^p$; 5) $x = p^3 - p + 2$, $y = \frac{3}{4}p^4 - \frac{1}{2}p^2 + C$;
 6) $x = 2p - \ln |p|$, $y = p^2 - p + C$; 7) $x = 2 \ln |p| - p$, $y = 2p - \frac{1}{2}p^2 + C$;
 8) $x = p^2 - p - 1$, $y = \frac{2}{3}p^3 - \frac{1}{2}p^2 + C$; 9) $y = \frac{1}{2}x^2 + C$, $y = -2x - \frac{x^2}{2} + C$; 10) $y = (\sqrt{x+1} + C)^2$.

3.1.21. 1) $x = Ce^p - 2(p+1)$, $y = Ce^p(p-1) - p^2 + 2$; 2) $x = -p - \frac{1}{2} + \frac{C}{(1-p)^2}$, $y = -\frac{1}{2}p^2 + \frac{Cp^2}{(1-p)^2}$;
 3) $x = \frac{C}{(p-1)^2} - 1$, $y = \frac{Cp^2}{(p-1)^2}$; 4) $x = \frac{C + \ln|p| - p}{(p-1)^2}$, $y = \frac{(C + \ln|p| - p)p^2}{(p-1)^2} + p$. 5) $y = Cx - C^4$,
 $y = \frac{3}{4\sqrt[4]{4}}x^{\frac{4}{3}}$; 6) $y = Cx + C - \sqrt{C}$; $y = -\frac{1}{4(x+1)}$; 7) $y = Cx + \frac{1}{C^2}$, $y = \frac{3x^{\frac{3}{2}}}{\sqrt[3]{4}}$; 8) $y = Cx + \frac{1}{C}$, $y = 2\sqrt{x}$.

3.2. Yuqori tartibli differensial tenglamalar

3.2.3. $y' > 0$. **3.2.4.** $y' < x^2$. **3.2.5.** 1) $y = x \arctg x - \ln|1+x^2| + C_1x + C_2$;
 2) $y = \frac{1}{6}x^3 \ln|x| - \frac{5}{36}x^3 + C_1x + C_2$; 3) $y = -\frac{1}{8}\sin 2x + \frac{1}{2}C_1x^2 + C_2x + C_3$;
 4) $y = \frac{1}{81}e^{3x} + \frac{1}{6}C_1x^3 + \frac{1}{2}C_2x^2 + C_3x + C_4$; 5) $y = \pm \frac{2}{3C_1}\sqrt{(C_1x-1)^3 + C_2}$; 6) $y = C_1x(\ln|x|-1) + C_2$;
 7) $y = -\frac{x^2}{4} + C_1 \ln|x| + C_2$; 8) $y^2 = 2e^x(x^2 - 4x + 6) + C_1x + C_2$; 9) $\ln\left|\frac{y}{y+C_1}\right| = C_1x + C_2$, $y = C$;
 10) $x = \frac{1}{3}y^3 + C_1y + C_2$, $y = C$; 11) $(x+C_2)^2 - y^2 = C_1$; 12) $x+C_2 = y + C_1 \ln|y|$;
 13) $y = \frac{x}{2} + C_1 \arctg x + C_2$; 14) $y = (C_1 \ln|x| + C_2)x$; 15) $y^2 = \frac{1}{3}x^3 + C_1x + C_2$;
 16) $y = \frac{1}{6}x^3 - \frac{1}{2}x^2 + C_1x \ln|x| + C_2x + C_3$; 17) $y = C_2e^{C_1x^2}$; 18) $y = \frac{C_2}{\cos^2\left(\frac{x}{2} + C_1\right)}$, $y = 0$.

3.2.6. 1) $y = -\ln|\cos x|$; 2) $y = -x \sin x - 2 \cos x + x$; 3) $y = \frac{1}{6}(x^3 - 3x^2 + 6x + 4)$;
 4) $y = \frac{2}{5}x^2\sqrt{2x} - \frac{16}{5}$; 5) $\operatorname{ctg} y = \pi - 2x$; 6) $y = -\ln|x-1|$; 7) $y = 3x$; 8) $y = e^{\frac{x^2}{2}}$.

3.3. Chizikli bir jinsli differensial tenglamalar

3.3.1. 1) chizikli erkin; 2) chizikli bog'liq; 3) chizikli bog'liq; 4) chizikli erkin.
3.3.2. 1) $y = C_1x + C_2(x^2 - 1)$; 2) $y = C_1x^3 + C_2x^4$; 3) $y = C_1e^{2x} + C_2xe^{2x}$; 4) $y = C_1 \sin x + C_2 \cos x$.
3.3.3. 1) $y = C_1 \frac{\cos x}{x} + C_2 \frac{\sin x}{x}$; 2) $y = (C_1 - C_2x) \operatorname{ctg} x + C_2$; 3) $y = C_1e^{-x} + C_2e^{3x}$;
 4) $y = C_1 \sin 2x + C_2 \cos 2x$. **3.3.4.** 1) $y'' - \frac{3}{x}y' + \frac{3}{x^2}y = 0$; 2) $y'' + \operatorname{tg} xy' = 0$; 3) $y'' - 6y' + 9y = 0$;
 4) $4y'' + 9y = 0$. **3.3.5.** 1) $y = C_1e^{3x} + C_2e^{-2x}$; 2) $y = C_1e^{(1-\sqrt{3})x} + C_2e^{(1+\sqrt{3})x}$; 3) $y = (C_1 + Cx)e^{2x}$;
 4) $y = (C_1 + C_2x)e^{-\frac{1}{3}x}$; 5) $y = e^{-2x}(C_1 \cos 5x + C_2 \sin 5x)$; 6) $y = e^x\left(C_1 \cos \frac{x}{2} + C_2 \sin \frac{x}{2}\right)$;
 7) $y = C_1 + C_2e^x + C_3e^{-2x}$; 8) $y = C_1e^x + e^{2x}(C_2 \cos 3x + C_3 \sin 3x)$;
 9) $y = (C_1 + C_2x) \cos 2x + (C_3 + C_4x) \sin 2x$; 10) $y = C_1 + C_2x + C_3x^2 + e^{3x}(C_4 + C_5x)$.
3.3.6. 1) $y = 4e^{-3x} - 3e^{-2x}$; 2) $y = xe^{4x}$; 3) $y = 2 + e^{-x}$; 4) $y = 2e^x + (x-1)e^{2x}$.

3.4. Chiziqli bir jinsli bo'lmagan differensial tenglamalar

3.4.1. $Y = C_1x^2 + C_2x + xe^x$. **3.4.2.** $Y = C_1x^3 + C_2x^4 + \frac{1}{2}x$. **3.4.3.** $Y = (C_1 + C_2x)e^x + \frac{1}{2}x^2e^x + \frac{1}{4}e^{-x}$.

3.4.4. $Y = C_1 + C_2e^{-x} + \frac{1}{2}e^x + \frac{1}{3}x^3 - x^2 + 2x$. **3.4.5.** 1) $Y = (C_1 + C_2x)e^x + x(\ln x - 1)e^x$;

2) $Y = C_1 + C_2e^x - \sin e^x$; 3) $Y = C_1 \cos x + C_2 \sin x + \sin x \ln |\sin x| - x \cos x$;

4) $Y = C_1 \cos x + C_2 \sin x + \frac{1}{2 \cos x}$. **3.4.6.** $Y = C_1e^x + C_2e^{2x} + \bar{y}_i$, 1) $\bar{y}_1 = e^{-x}$; 2) $\bar{y}_2 = 3xe^{2x}$;

3) $\bar{y}_3 = e^x(2x^2 + x)$; 4) $\bar{y}_4 = e^x(\cos x - \sin x)$.

3.4.7. 1) $\bar{y} = A + (A_1x + B_1)e^{2x} + x \cdot ((A_2x^2 + B_2x + D_1) \cos x + (A_3x^2 + B_3x + D_3) \sin x)$;

2) $\bar{y} = A + x(A_1x + B_1)e^x + e^x(A_2 \cos x + B_2 \sin x)$;

3) $\bar{y} = x(Ax + B) + (A_1x^2 + B_1x + D_1)e^x + x \cdot ((A_2x + B_2) \cos x + (A_3x + B_3) \sin x)$;

4) $\bar{y} = Ax^2 + x(A_1x + B_1)e^x + (A_2x + B_2) \cos x + (A_3x + B_3) \sin x$. **3.4.8.** 1) $Y = C_1 + C_2e^{-x} + x^2 + x$;

2) $Y = (C_1 + C_2x)e^x + x + 6$; 3) $Y = e^x(C_1 \cos x + C_2 \sin x) + \frac{1}{2}(x+1)^2$; 4) $Y = C_1 + C_2e^{3x} - x^3 - x^2 - \frac{2}{3}x$;

5) $Y = C_1 + C_2e^{-x} + e^x$; 6) $Y = C_1e^x + C_2e^{-x} - \frac{1}{2}xe^{-x}$; 7) $Y = (C_1 + C_2x)e^x + \frac{1}{6}x^3e^x$;

8) $Y = C_1 + C_2e^{4x} + \frac{1}{16}(2x^2 - x)e^{4x}$; 9) $Y = (C_1 + C_2x)e^{-x} + \frac{1}{2} \sin x$;

10) $Y = C_1e^{2x} + C_2e^{3x} + \frac{1}{3}(5 \cos 3x - \sin 3x)$; 11) $Y = C_1 \cos x + C_2 \sin x - \frac{1}{4}x^2 \cos x + \frac{1}{4}x \sin x$;

12) $Y = C_1 + C_2e^{2x} - \frac{1}{5}\left(x + \frac{14}{3}\right) \cos x - \frac{2}{5}\left(x + \frac{5}{3}\right) \sin x$; 13) $Y = C_1e^x + C_2e^{6x} + \frac{1}{26}e^x(5 \cos x - \sin x)$;

14) $Y = C_1e^{3x} + C_2e^{-3x} + \frac{1}{37}e^{3x}(6 \sin x - \cos x)$; 15) $Y = C_1e^{2x} + C_2e^{3x} + \frac{1}{2}e^x + \frac{1}{6}\left(x^2 + \frac{5}{3}x + \frac{19}{18}\right)$;

16) $Y = C_1 \cos x + C_2 \sin x + \frac{1}{2}(x-1)e^x + e^{-x}$; 17) $Y = C_1 + C_2x + C_3e^{-x} + xe^{-x}$;

18) $Y = C_1 + (C_2 + C_3x)e^x + \frac{1}{6}x^2(x-3)e^x$; 19) $Y = C_1e^x + C_2e^{-x} + C_3 \cos x + C_4 \sin x + \frac{1}{4}xe^x$;

20) $Y = C_1 + C_2x + C_3e^x + C_4e^{-x} - \frac{1}{2}x^3$. **3.4.9.** 1) $Y = C_1e^{2x} + C_2e^x + e^{2x}(x - \ln(e^x + 1))$;

2) $Y = (C_1 + C_2x)e^x + \frac{1}{2}e^x\left(\sqrt{4-x^2} + x \arcsin \frac{x}{2}\right)$.

3.5. Differensial tenglamalar sistemalari

3.5.1. 1) $y' = y_1$, $y_1' = 2y_1 - 3y_2$; 2) $y' = y_1$, $y_1' = y_2$, $y_2' = y_2^2 + y_2 - xy_1$; 3) $y_1' = \cos x + \sin x - y_2$, $y_2' = 4 \cos x + 3 \sin x + 3y_1 - 4y_2$; 4) $y_1' = y_3$, $y_2' = y_4$, $y_3' = y_5$, $y_4' = 2y_1 - y_2$, $y_5' = y_1 - y_2 + x$.

3.5.2. 1) $y_1 = C_1x$, $y_2 = \pm\sqrt{C_2 - (1 + C_1^2)x^2}$; 2) $y_1 = C_1e^x + C_2e^{-x} - 1$, $y_2 = \pm\sqrt{C_1e^x - C_2e^{-x} - x}$;

3) $y_1 = C_1C_2e^{C_1x}$, $y_2 = C_2e^{C_1x}$; 4) $y_1 = C_1x - \frac{C_2}{x}$, $y_2 = -C_1x - \frac{C_2}{x}$; 5) $y_1 = C_1e^{-x} + C_2e^{-3x}$,

$y_2 = C_1 e^{-x} + 3C_2 e^{-3x} + \cos x$; 6) $y_1 = C_1 + C_2 e^{-2x} + e^x$, $y_2 = C_1 - C_2 e^{-2x} + e^x$. **3.5.3.** 1) $y_1 = 2 \sin x$, $y_2 = e^x + \sin x - \cos x$, $y_3 = e^x + \sin x + \cos x$; 2) $y_1 = e^x - 1$, $y_2 = (1+x)e^x - x$, $y_3 = x(e^x - 1)$.

3.5.4. 1) $y_1 = C_1 e^x + C_2 e^{-x}$, $y_2 = C_1 e^x - C_2 e^{-x}$; 2) $y_1 = \frac{C_1}{C_2} e^{\frac{x^2}{2}} + C_2 e^{-\frac{x^2}{2}}$, $y_2 = \frac{C_1}{C_2} e^{\frac{x^2}{2}} - C_2 e^{-\frac{x^2}{2}}$;

3) $y_1 - C_1 y_2 = 0$, $x + y_1 - 2y_2 = C_2$; 4) $y_1 = \frac{C_1 + C_2 - x}{\sqrt{2(C_2 - x)}}$, $y_2 = \frac{C_1 - C_2 + x}{\sqrt{2(C_2 - x)}}$, 5) $x + y_1 + y_2 = C_1$,

$x^2 + y_1^2 + y_2^2 = C_2$; 6) $y_1 - C_1 y_2 = 0$, $x^2 = C_2 y_1 (x^2 + y_1^2)$. **3.5.5.** 1) $y_1 = C_1 e^{4x} + C_2 e^x$, $y_2 = C_1 e^{4x} - 2C_2 e^x$; 2) $y_1 = 3C_1 e^{2x} + C_2 e^{4x}$, $y_2 = C_1 e^{2x} + C_2 e^{4x}$; 3) $y_1 = e^{4x} (C_1 + C_2 x)$, $y_2 = e^{4x} (-2C_1 x - C_1 - 2C_2)$; 4) $y_1 = e^{-x} (2C_1 + C_2 + 2C_2 x)$, $y_2 = e^{-x} (C_1 + C_2 x)$;

5) $y_1 = e^x (C_1 \cos x + C_2 \sin x)$, $y_2 = e^x (C_1 \sin x - C_2 \cos x)$; 6) $y_1 = e^{2x} (C_1 \cos x + C_2 \sin x)$,

$y_2 = e^{2x} (C_1 \sin x - C_2 \cos x)$; 7) $y_1 = C_1 + 3C_2 e^{2x}$, $y_2 = -2C_2 e^{2x} + C_3 e^{-x}$, $y_3 = C_1 + C_2 e^{2x} - 2C_3 e^{-x}$;

8) $y_1 = C_1 e^{-x} + C_2 e^{2x} + C_3 e^{-2x}$, $y_2 = C_1 e^{-x} + C_2 e^{2x} - C_3 e^{-2x}$, $y_3 = -C_1 e^{-x} + 2C_2 e^{2x}$;

9) $y_1 = C_1 e^x + C_2 e^{-x} + x - 1$, $y_2 = C_1 e^x - C_2 e^{-x} - x + 1$; 10) $y_1 = C_1 + C_2 e^{-x} + \frac{3}{2} e^x - x + 1$,

$y_2 = -C_2 e^{-x} + \frac{1}{2} e^x + x - 1$; 11) $y_1 = 2C_1 e^{2x} + C_2 e^{-3x} - \frac{2}{3} x - \frac{5}{18}$, $y_2 = C_1 e^{2x} + 3C_2 e^{-3x} - \frac{1}{2} x - \frac{1}{12}$;

12) $y_1 = C_1 \cos x + C_2 \sin x + 1 - \frac{1}{2} e^x$, $y_2 = C_1 \sin x - C_2 \cos x + x + \frac{1}{2} e^x$.

4.1. Sonli qatorlar

4.1.1. 1) $\frac{11}{18}$; 2) $\frac{1}{14}$; 3) $\frac{1}{15}$; 4) $\frac{1}{3}$; 5) 1; 6) $\frac{1}{2}$; 7) uzoqlashadi; 8) uzoqlashadi; 9) $\frac{3}{4}$; 10) 8;

11) uzoqlashadi; 12) uzoqlashadi. **4.1.2.** 1) yaqinlashadi; 2) uzoqlashadi; 3) yaqinlashadi; 4) yaqinlashadi; **4.1.3.1)** uzoqlashadi; 2) yaqinlashadi; 3) yaqinlashadi; 4) yaqinlashadi.

4.1.4.1) yaqinlashadi; 2) yaqinlashadi; 3) uzoqlashadi; 4) uzoqlashadi. **4.1.5.1)** yaqinlashadi;

2) yaqinlashadi; 3) yaqinlashadi; 4) uzoqlashadi. **4.1.6.1)** yaqinlashadi; 2) uzoqlashadi;

3) uzoqlashadi; 4) yaqinlashadi. **4.1.7.1)** yaqinlashadi; 2) yaqinlashadi; 3) uzoqlashadi;

4) yaqinlashadi; 5) yaqinlashadi; 6) yaqinlashadi; 7) yaqinlashadi; 8) yaqinlashadi;

9) yaqinlashadi; 10) yaqinlashadi. **4.1.9.1)** yaqinlashadi; 2) yaqinlashadi; 3) yaqinlashadi;

4) $\alpha > 0$ da yaqinlashadi, $\alpha \leq 0$ da uzoqlashadi; 5) uzoqlashadi; 6) uzoqlashadi.

4.1.10. 1) absolut yaqinlashadi; 2) absolut yaqinlashadi; 3) absolut yaqinlashadi;

4) shartli yaqinlashadi; 5) shartli yaqinlashadi; 6) uzoqlashadi; 7) uzoqlashadi;

8) absolut yaqinlashadi; 9) absolut yaqinlashadi; 10) absolut yaqinlashadi.

4.2. Funktsional qatorlar

4.2.1. 1) $(-\infty; -1) \cup (1; +\infty)$; 2) $(-\infty; 0)$; 3) $\left(-\frac{1}{2}; \frac{1}{2}\right)$; 4) $\left(\frac{21}{10}; 12\right)$; 5) $(-\infty; +\infty)$; 6) $(e; +\infty)$.

4.2.2. 1) $(-\infty; +\infty)$; 2) $[-2; 2]$; 3) $(-\infty; +\infty)$; 4) $[-3; 3]$; 5) $(-\infty; +\infty)$; 6) $(-\infty; +\infty)$. **4.2.3.** 1) $[-3; 3]$;

2) $\left[-\frac{1}{2}; \frac{1}{2}\right)$; 3) $[-2; 2)$; 4) $\left(-\frac{\sqrt{3}}{2}; \frac{\sqrt{3}}{2}\right)$; 5) $(-e; e)$; 6) $(-1; 1]$; 7) $[-3; -1]$; 8) $(-6; -2]$;

9) $(-\sqrt{10}; \sqrt{10})$; 10) $[-2; 2]$; 11) $[-2 - \sqrt{3}; -2 + \sqrt{3}]$; 12) $\left[-\frac{1}{3}; \frac{1}{3}\right]$; 13) $\{0\}$; 14) $(0; 4)$.

4.2.4. 1) $\arctg x$, $|x| \leq 1$; 2) $-\frac{1}{2} \ln|1-x^2|$, $|x| < 1$; 3) $\frac{2x}{(1-2x)^2}$, $|x| < \frac{1}{2}$; 4) $\frac{1+x}{(1-x)^3}$, $|x| < 1$.

4.2.5. $f(x) = 8 - 18(x+1) + 18(x+1)^2 - 8(x+1)^3 + (x+1)^4$.

4.2.6. $f(x) = 3(x-1) + 7(x-1)^2 + 9(x-1)^3 + 5(x-1)^4 + (x-1)^5$. **4.2.7.** 1) $\sum_{n=0}^{\infty} \frac{3x^n}{4^{n+1}}$, $(-4; 4)$;

2) $\sum_{n=0}^{\infty} \frac{(-1)^n 2^n x^{n+1}}{3^{n+1}}$, $\left(-\frac{3}{2}; \frac{3}{2}\right)$; 3) $\sum_{n=0}^{\infty} \left(1 + \frac{(-1)^n}{2^{n+1}}\right) x^n$, $(-1; 1)$; 4) $\sum_{n=1}^{\infty} \frac{(-1)^{n-1} (4^n + 3^n) x^n}{n}$, $\left(-\frac{1}{4}; \frac{1}{4}\right)$;

5) $e \sum_{n=1}^{\infty} \frac{2^n x^{2n+1}}{n!}$, $(-\infty; \infty)$; 6) $\sum_{n=1}^{\infty} (-1)^{n-1} \frac{2^{4n-3} x^{2n}}{(2n)!}$, $(-\infty; \infty)$. **4.2.8.** 1) 0,0953; 2) 0,2094; 3) 1,6487;

4) 8,0411. **4.2.9.** 1) $C + \sum_{n=0}^{\infty} (-1)^n \frac{x^{2n+1}}{(2n+1)(2n+1)!}$, $(-\infty; +\infty)$; 2) $C + \ln|x| + \sum_{n=1}^{\infty} \frac{x^n}{n \cdot n!}$, $(-\infty; 0) \cup (0; +\infty)$;

3) $\sum_{n=1}^{\infty} (-1)^{n-1} \frac{x^n}{n^2}$, $[-1; 1]$; 4) $\sum_{n=0}^{\infty} (-1)^n \frac{x^{4n+1}}{(2n)!(4n+1)}$, $(-\infty; +\infty)$. **4.2.10.** 1) 0,2398; 2) 0,2449; 3) 0,1991;

4) 0,7635. **4.2.11.** 1) $y(x) = 1 + x + x^2 + \frac{4}{3}x^3$; 2) $y(x) = 1 + 2x - \frac{x^2}{2} - \frac{5}{3}x^3$;

3) $y(x) = 1 + \frac{x^3}{6} + \frac{x^4}{24} + \frac{x^5}{40}$; 4) $y(x) = 1 + \frac{x^2}{2} + \frac{x^3}{6} + \frac{x^5}{120}$. **4.2.12.** 1) $\sum_{n=0}^{\infty} (-1)^{n+1} \frac{x^{2n}}{2^n n!}$, $(-\infty; +\infty)$;

2) $\sum_{n=1}^{\infty} \frac{2^{n-1} (2n-1)! x^{2n+1}}{(2n+1)!}$, $(-\infty; +\infty)$.

4.3. Fure qatorlari

4.3.1. 1) $f(x) = \frac{\pi^2}{3} + 4 \sum_{n=1}^{\infty} (-1)^n \frac{\cos nx}{n^2}$; 2) $f(x) = \sum_{n=1}^{\infty} (-1)^n \left(\frac{12}{n^3} - \frac{2\pi^2}{n} \right) \sin nx$;

3) $f(x) = \frac{\pi}{2} + \sum_{n=1}^{\infty} \left(\frac{2}{\pi n^2} ((-1)^n - 1) \cos nx + \frac{2}{n} (-1)^{n+1} \sin nx \right)$; 4) $f(x) = \pi + 2 \sum_{n=1}^{\infty} \frac{\sin nx}{n}$;

5) $f(x) = \frac{16}{\pi} \sum_{n=1}^{\infty} \frac{\sin(2n-1)x}{2n-1}$; 6) $f(x) = \frac{\pi}{4} + \sum_{n=1}^{\infty} \left(-\frac{2}{\pi(2n-1)^2} \cos(2n-1)x + (-1)^{n+1} \frac{\sin nx}{n} \right)$;

7) $f(x) = -\frac{1}{2} + \frac{12}{\pi^2} \sum_{n=1}^{\infty} \frac{1}{(2n-1)^2} \cos \frac{(2n-1)\pi}{3} x$; 8) $f(x) = 1 - \frac{2}{\pi} \sum_{n=1}^{\infty} \frac{\sin 2n\pi x}{n}$;

9) $f(x) = \frac{3}{2} - \frac{6}{\pi} \sum_{n=1}^{\infty} \frac{1}{(2n-1)} \sin \frac{(2n-1)\pi}{2} x$;

10) $f(x) = \frac{3}{4} - \frac{3}{\pi} \sum_{n=1}^{\infty} \left(-\frac{2}{\pi(2n-1)^2} \cos \frac{(2n-1)\pi x}{3} + \frac{(-1)^n}{n} \sin \frac{n\pi x}{3} \right)$; 11) $f(x) = \frac{8}{\pi} \sum_{n=1}^{\infty} \frac{\cos(2n+1)x}{(2n+1)^2}$;

12) $f(x) = \frac{5}{4} + \frac{2}{\pi} \sum_{n=1}^{\infty} \left(\frac{(-1)^{n-1}}{2n-1} \cos \frac{(2n-1)\pi x}{2} - \frac{2}{n^2 \pi} \cos \frac{n\pi x}{2} \right)$; 13) $f(x) = \frac{2}{\pi} \sum_{n=1}^{\infty} (-1)^{n+1} \frac{\sin n\pi x}{n}$;

14) $f(x) = 2 \sum_{n=1}^{\infty} \left(\pi \frac{(-1)^{n+1} \sin nx}{n} + \frac{4 \sin(2n+1)x}{\pi (2n+1)^3} \right)$. **4.3.2.1)** 1) $\frac{\pi^2}{12}$; 2) $\frac{\pi}{4}$.

Ayrim chiziqlarning grafiklari va tenglamalari

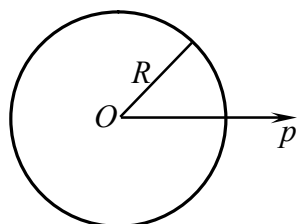

$$r = R$$

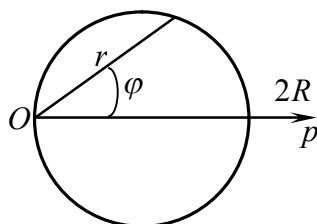

$$r = 2R \cos \varphi$$

R radiusli aylana

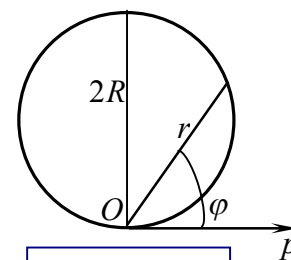

$$r = 2R \sin \varphi$$

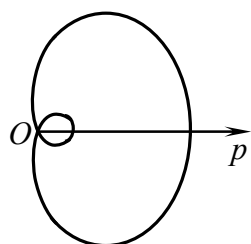

$$r = b + a \cos \varphi \quad (a > b)$$

Paskal chig'anog'i

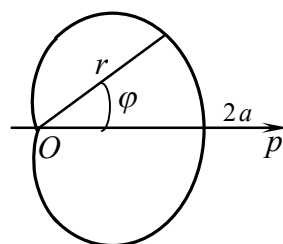

$$r = a(1 + \cos \varphi) \quad (a > 0)$$

Kardioida

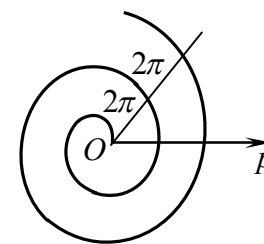

$$r = a \varphi \quad (a > 0)$$

Arximed spirali

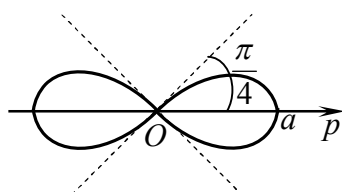

$$r = a \sqrt{\cos 2\varphi} \quad (a > 0)$$

$$(x^2 + y^2)^2 - a^2(x^2 - y^2) = 0$$

Bernulli limniskatasi

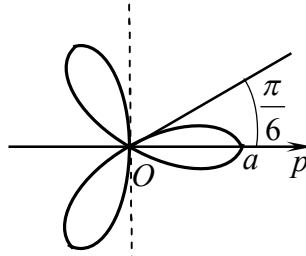

$$r = a \cos 3\varphi \quad (a > 0)$$

Uch yaproqli gul

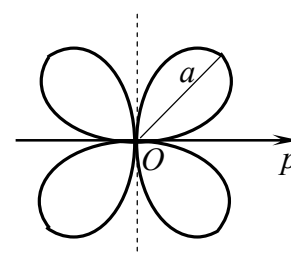

$$r = a \sin 2\varphi \quad (a > 0)$$

To'rt yaproqli gul

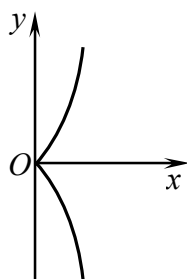

$$y^2 = x^3 \quad \text{yoki} \quad \begin{cases} x = t^2, \\ y = t^3 \end{cases}$$

Yarimkubik parabola

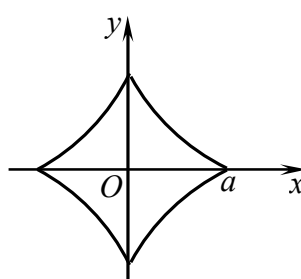

$$x^{\frac{2}{3}} + y^{\frac{2}{3}} = a^{\frac{2}{3}} \quad \text{yoki} \quad \begin{cases} x = a \cos^3 t, \\ y = a \sin^3 t \end{cases}$$

Astroida

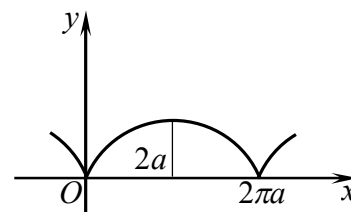

$$\begin{cases} x = a(t - \sin t), \\ y = a(1 - \cos t), \quad a > 0 \end{cases}$$

Sikloida

MUNDARIJA

SO‘Z BOSHI	3
I bob. BIR NECHA O‘ZGARUVCHI FUNKSIYALARINING DIFFERENSIAL HISOBI	
1.1. Bir hecha o‘zgaruvchining funksiyalari.....	4
1.2. Bir hecha o‘zgaruvchining funksiyasini differensiallash	15
1.3. Bir hecha o‘zgaruvchining funksiyasini ekstremumga tekshirish ...	30
1.4. Nazorat ishi	41
1.5. Mustaqil ish	44
II bob. BIR NECHA O‘ZGARUVCHI FUNKSIYALARINING INTEGRAL HISOBI	
2.1. Ikki karrali integral	69
2.2. Uch karrali integral	83
2.3. Egri chizikli integrallar	91
2.4. Sirt integrallari	106
2.5. Maydonlar nazariyasi elementlari	117
2.6. Nazorat ishi	129
2.7. Mustaqil ish	132
III bob. ODDIY DIFFERENSIAL TENGLAMALAR	
3.1. Birinchi tartibli differensial tenglamalar	154
3.2. Yuqori tartibli differensial tenglamalar	178
3.3. Chizikli bir jinsli differensial tenglamalar	187
3.4. Chizikli bir jinsli bo‘lmagan differensial tenglamalar	194
3.5. Differensial tenglamalar sistemalari	204
3.6. Nazorat ishi	218
3.7. Mustaqil ish	223
IV bob. SONLI VA FUNKSIONAL QATORLAR	
4.1. Sonli qatorlar	239
4.2. Funksional qatorlar	250
4.3. Fure qatorlari	265
4.4. Nazorat ishi	270
4.5. Mustaqil ish	274
Foydalanilgan adabiyotlar	289
Javoblar	290
Ilova	299